

OMRON

SCALABLE MACHINE AUTOMATION

confidence

presence

assurance

competence

When we say it works,

...IT WORKS !

OMRON

Turning ideas into machines that work...

With over 50,000 buying machine builders world-wide - 10,000 in Europe - and 50 years experience in machine automation, we particularly pride ourselves in helping these companies turn their dreams into reality... world class machines. Because when we say it works, IT WORKS!

This statement embodies our core values of supporting you with competent and experienced people, quality products that work in conditions far beyond their published specifications and always maintaining our commitment to you the customer.

We are successful because we provide solutions based on our customers needs, whether that solution is used in a fixed form through to a highly flexible machine.

We believe this is a solid base to start turning YOUR IDEAS into MACHINES THAT WORK.

Lean Automation



Lean Automation

Dedicated for One machine/One function. Simple, compact and easy to use and maintain solution.

- Rugged and robust PLC control
- Up to 4 axis of point-to-point motion
- HMI, servo and inverters included
- Remote access to the controller

X-Stream Automation

Stream Automation



Stream Automation

Dedicated for fast and flexible flow-automation. By introducing network connectivity the system can be configured in a highly flexible manner, and provides a single access point to the whole machine.

- Motion bus: Up to 30 axes of motion
- One software for all automation tasks
- Active visualization with smart functionality for device monitoring and configuration
- Remote access across all the automation layers



X-Stream Automation

It is dedicated for flexible production cells. It has as core "Stream Automation" with faster controllers and motion networks. It includes robotics, vision systems and machine SCADA.

- 64 axis motion control in less than 1 ms
- IPC for visualization and data storage
- SCARA robot and linear motor stages
- 2D and 3D inspection plus fast positioning via Xpectia vision system

LEAN AUTOMATION

Description

Addresses small and compact machines performing one dedicated task. It can fit into stand-alone machines or modules within a larger machine. Its merit lies in its simplicity, compactness and cost performance.

Your benefits

- » Cost effective solution without compromising on quality and performance
- » Simplicity of programming and wiring
- » Space saving thanks to ultra-compact product designs and side-by-side mounting of inverters
- » Remote diagnostics with optional Ethernet or RS485 interface
- » State of the art colour HMI

Key features

Compact, fast and rugged automation (CP1 series)

- » Compact PLC with up to 40 built-in and 320 expandable I/O
- » 4 axis PTP motion control up to 1MHz pulse output
- » 20Ksteps program capacity
- » 4 high speed counters (100kHz)
- » USB port for easy programming

Motion control capability

- » Modbus RS485 port or analog output to inverters (JX)
- » General motion commands for point to point positioning

Temperature regulation

- » PLC based built-in PID commands
- » Panel mounted, one-touch tune temperature controllers

HMI

- » 3" and 5" touch panels (NQ series)
- » 256 colors with STN technology
- » 50,000hr backlight lifetime

Servicing

- » Remote servicing can be performed to the controller level

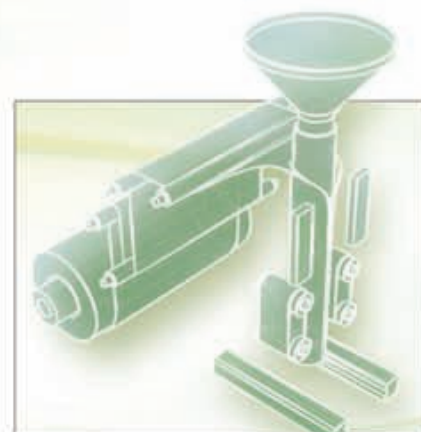
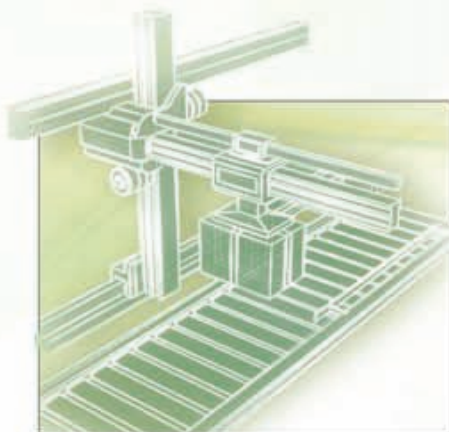
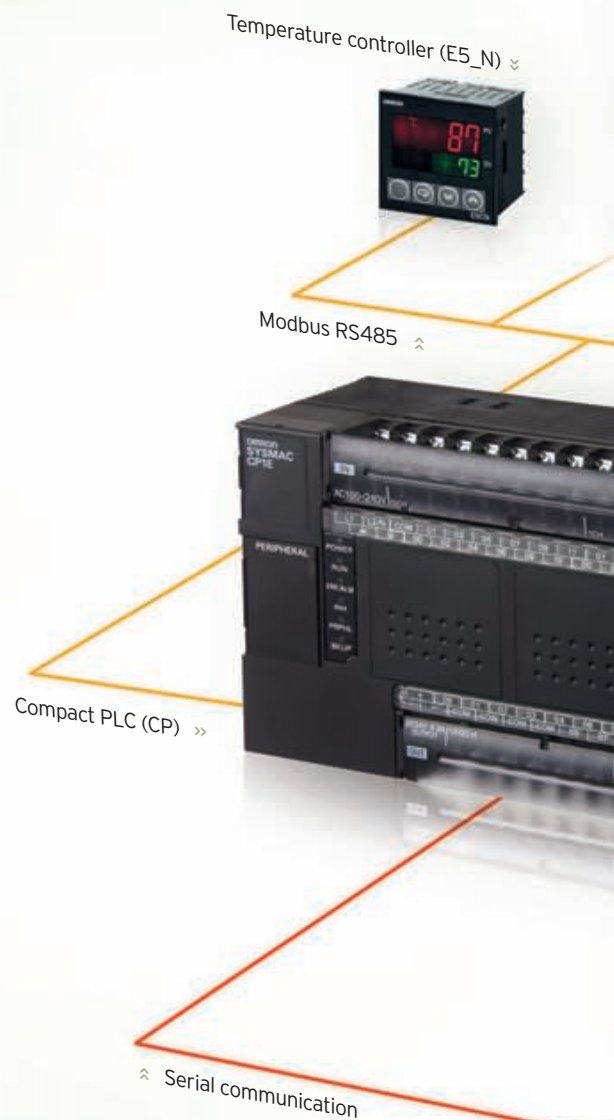

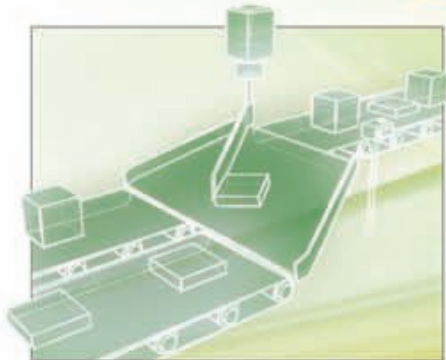

Single head labelling ≈

STREAM AUTOMATION

Description

Aimed at flexible and high speed continuous automation, it relies on "all-digital" connectivity across all layers. Essential functions like control, motion, regulation and safety are handled through one software and all devices are accessed via one single point. This integrated approach allows for easy programming and full remote servicing down to the field device level.

Your benefits

- » Highly flexible machines thanks to an all digital motion control platform
- » Compact machines due to side by side mounting of ultra-slim servo and inverter drives
- » Rugged, reliable and fast control
- » One software and one connection allow full machine management

Key features

Integrated automation architecture

- » One software (CX-One) for configuration, programming and visualization
- » 4 programming languages: ladder, ST, SFC and FB
- » Serviceability: one access point to all devices

Advanced motion control

- » PTP or advanced motion control
- » Up to 30 axis of control in less than 1ms

Modular multi-loop temperature control

- » Up to 250 loops
- » Fastest and most accurate control in the market

Safety control

- » Safety category 3 in servo and inverter drives as standard
- » Modular safety network controller (NE1A)

Open automation

- » Robust and reliable PLC based control (less than 100ppm failure rate)
- » Open: supports master and slave units for Profibus, CAN, Profinet, DeviceNet and EtherNet/IP
- » SmartSlice with built-in diagnostics

Visualization

- » HMI: from 5.7 to 15" TFT screen
- » Integrated Web server

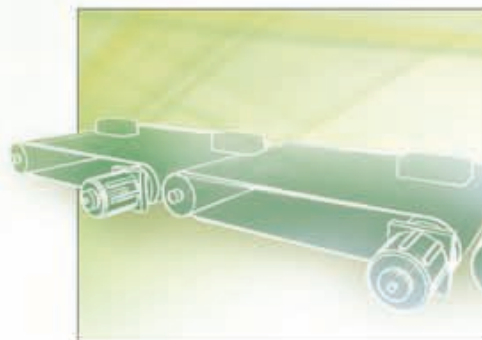
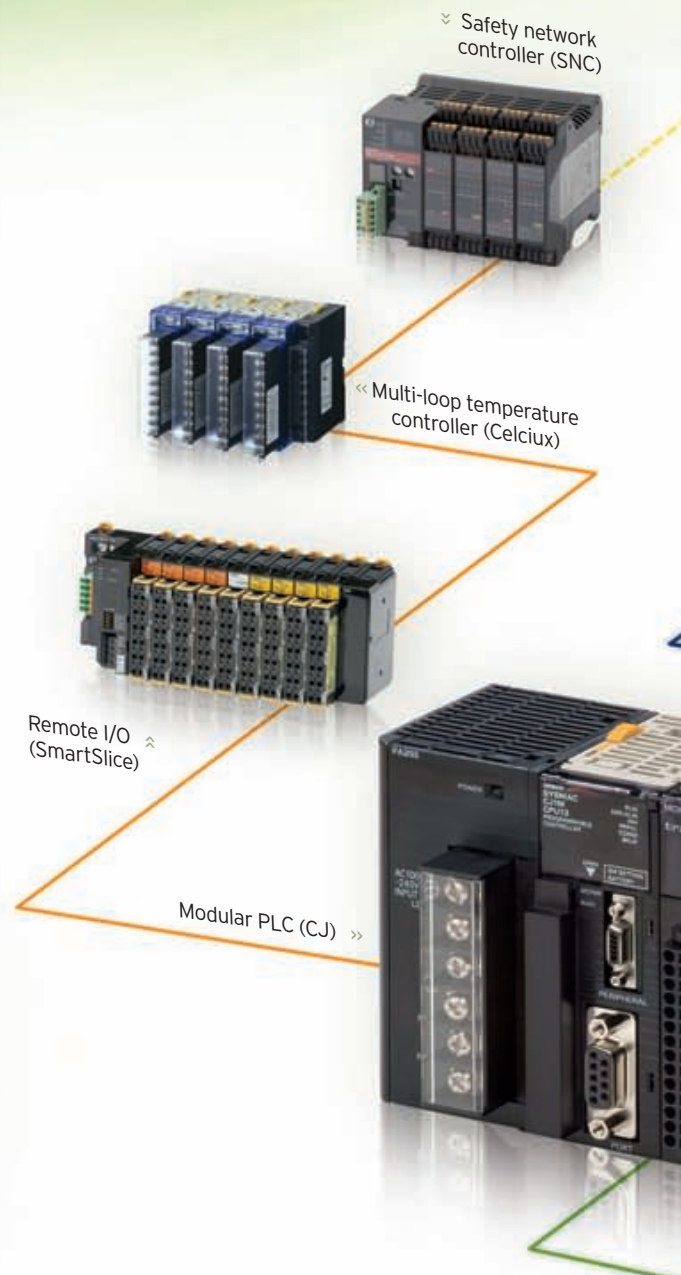

⚡ Main conveyor

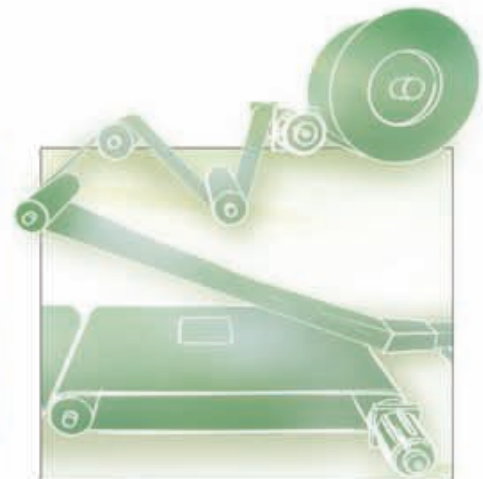

⚡ Film feeder



≈ Servo drives (Accurax G5)

≈ Inverter drives (MX2)

≈ Motion network - ML2



≈ Visualization (NS HMI)

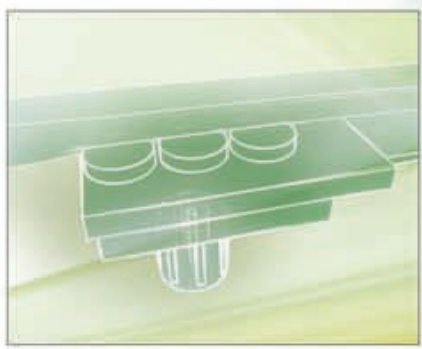

≈ Longitudinal sealer

Transversal sealer ≈

X-STREAM AUTOMATION

Description

X-Stream Automation is dedicated for complete production cell control. It offers the highest machine performance levels based on ONE machine controller, an ultra-fast Ethernet based Fieldbus, an IPC based HMI and the integration of vision and robotics as key elements in the automation solution. Above all, it is about your people and our people engaging in ONE common challenge: creating extreme machines!

Your benefits

- » A single source supplier of products and expertise
- » Faster machines utilising leading edge controller, servo and network products
- » Compact machines through the use of the latest design drives, robots and digital networks
- » Integrated Vision and inspection capability

Key features

Machine control (Trajexia 64)

- » One machine controller: Provides PLC and motion functionality under the IEC61131 programming standard
- » 64 bit microprocessor allows for fast and highly accuracy control. Suitable for kinematics and robotics functions
- » Up to 64 axis of synchronised motion

Network (Ethernet based)

- » EtherCAT for motion and field devices
- » Ethernet for factory level communication

Visualisation (Dyalox IPC)

- » Industrialised design with no moving parts
- » CX Supervisor easily installed to manage your machine

Robotics (SCARA)

- » Rugged and compact design with no belts or moving electronic parts
- » Up to 50kg payload and 1200mm reach
- » Vision and conveyor tracking functionality

Quality inspection (Xpectia)

- » PC based Color and 3D functionality
- » PC based with comprehensive and expandable application library



» SCARA robots



» Ethernet

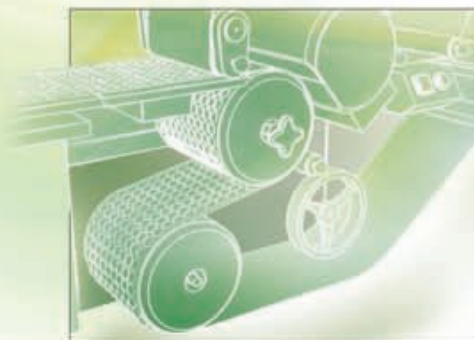

» Blister Packaging Machines



» Filling and capping



Linear motors ^



Accurax G5 v

MX2 v



^ EtherCAT



v Trajexia Machine Controller

v Xpectia: Dedicated vision system



Dyalox IPC v

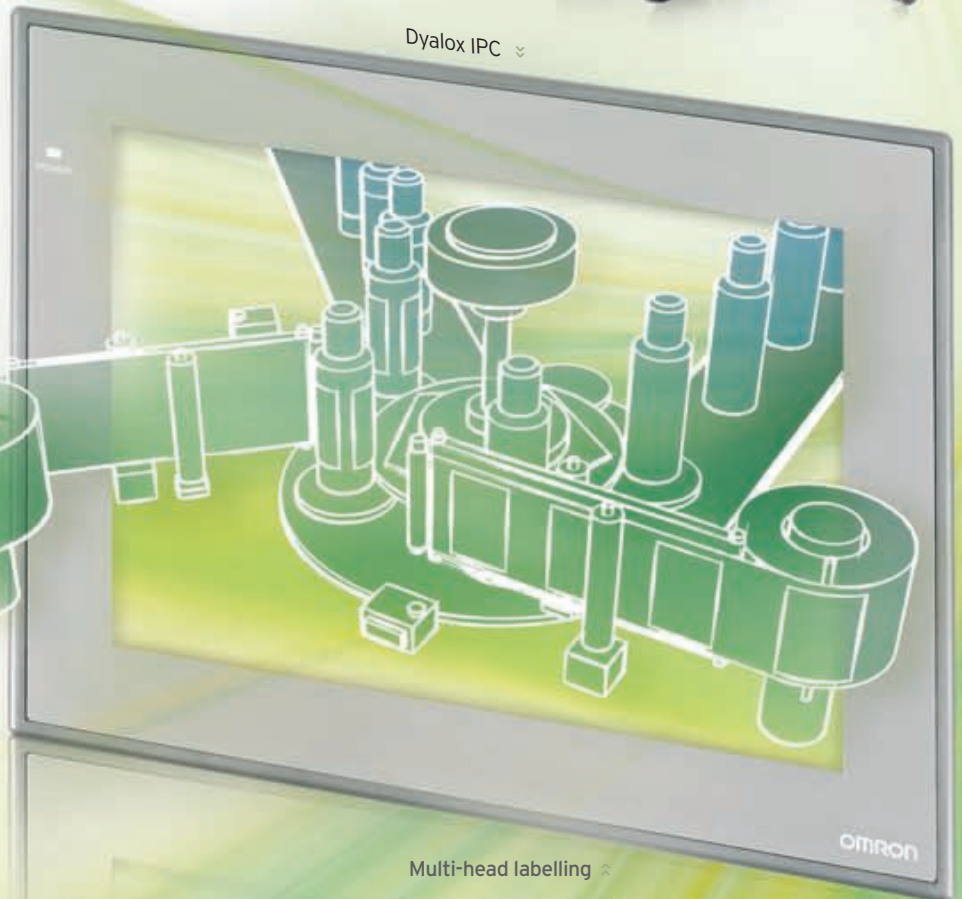

Multi-head labelling v

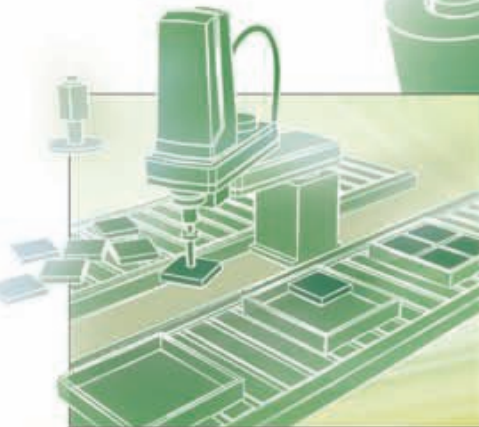

^ Pick & Place with SCARA

OMRON

When we say it works, ...IT WORKS.

Products and concepts alone are never enough, this is why we are going to be with you at every stage, helping you to create faster, smarter and cost effective machines



from your first idea,

YOU

First Idea

Automation Architecture

Proof of concept

COMPETENCE

OMRON

Sales engineer

Application engineer

Product specialist



Share your ideas with our salesmen. They have the experience and competence, and are empowered to make decisions. Thousands of OEM's have put their trust in them to date.

As soon as our involvement starts, an application engineer is appointed to coordinate all of the technical aspects of the project. The primary role is to agree the machine automation architecture, aligned to your technical and business needs.

Before embarking on costly developments, a proof of concept can be undertaken with our application and technology specialists, within one of our 6 European Competence Centres, or alternatively one of our 50 locally based technical offices.

...to your final machine!



Design &
Development

Field
Testing

Serial
Production

CONFIDENCE

ASSURANCE

Customer
Service

Liaison
engineer

After Sales
support



As your development begins, we will appoint a dedicated Customer Service member, available to handle all logistic enquiries and ensure you can keep your mind on the real issues.

As a global manufacturer, we can assign a contact person local to where you are installing machines, there on hand to help with technical and logistic support, as well as arranging training for your customers.

Throughout the life cycle of your machine, Omron offers reliable supply, regular software upgrades, rapid repair service and effective global support to your end users. Our standard commitment includes:

- 5 day repair door to door
- 2 day delivery
- 2 hour handling time for express orders, from order entry to courier pick-up

A global company that refuses to be big

OMRON Automation Competence Centres and technical offices across the World

- Automation Competence centre
- Technical office
- Premium partner



Product features at a glance Scalable Machine Automation

X-Stream Automation

Machine Control

Trajexia machine controller



- From 4 to 64 axis
- EtherCAT, ML-II Motion Bus
- Complex interpolation moves, e-cams and e-gearboxes
- IEC 61131 language support

Visualization

Dyalox IPC



- Industrial-grade 600 MHz or 1.3 GHz Intel Celeron CPU
- No HDD, silicon storage up to 8GB
- Fan-less heat sink cooling for enhanced reliability

Servo drives

Accurax G5 EtherCAT



- Power range from 50 W to 5 kW
- Embedded safety
- Advanced vibration suppression functions
- Servo motors with IP67 protection and low torque cogging

Inverters

MX2 inverter



- Safety embedded
- Current vector control
- 200 % starting torque
- IM & PM motor control

Stream Automation

CJ PLC



- 30 axis Trajexia motion control unit
- Up to 2560 I/O
- Specialised control units for motion control
- IEC 61131 compliant programming

NS HMI



- From 5.7 up to 15 inch
- Up to 1024 x 768 pixels resolution
- Trending and data logging
- Ladder Monitor & PLC Data Trace function

Accurax G5 MECHATROLINK-II



- Power range from 50 W to 5 kW
- Embedded safety
- Advanced vibration suppression functions
- Servo motors with IP67 protection and low torque cogging

MX2 inverter (soon)



- Safety embedded
- Current vector control
- 200 % starting torque
- IM & PM motor control

Lean Automation

CP PLC



- 4 axis PTP motion control up to 1MHz pulse output
- Up to 320 I/O
- Serial, Ethernet, Controller Link, DeviceNet, Profibus-DP, CAN, CompoBus/S

NQ HMI



- 3.5" TFT and 5.7" STN
- 320x240 pixel resolution
- RS-232, RS-422A/RS-485, USB Host, USB Slave, option port

SmartStep 2 servo drive



- Pulse control
- High resolution (10,000 p/rev) with feedback output
- Available up to 750 W

JX inverter



- Side by side mounting
- Built-in EMC filter and RS-485 Modbus
- Overload detection function
- Second motor setting

Remote I/O, safety and regulation

SmartSlice distributed I/O



- Diagnostics in every I/O unit
- Supports a wide range of networks
- Detachable terminal blocks
- Hot-swapping
- Up to 64 I/O units

Total solutions for industrial safety



- Safety light curtains
- Safety relay units
- Safety switches
- Emergency stop buttons

Regulation solutions



- From single loop to modular multi-channel controller
- Handles voltage, mA, Pt and thermocouple inputs
- Gradient and 2 PID control
- Modbus RTU, Profibus, DeviceNet

Robotics and Vision

Dedicated vision systems

- High resolution cameras: 5 million pixels
- Touch-screen for easy operation



SCARA robots

- Reach from 120 mm to 1200 mm and payload up to 50 Kg
- Simple programming and quick set-up
- Higher precision and speed



Software tools

CX-One is the complete machine automation software. Key points are:

- One software for control, visualisation and general motion coordination
- One instruction set across all PLC's
- Off line machine simulation for control and visualisation
- Rich software modules library for robotics, kinematics and vision coordination



OMRON EUROPE B.V. Wegalaan 67-69, NL-2132 JD, Hoofddorp, The Netherlands. Tel: +31 (0) 23 568 13 00 Fax: +31 (0) 23 568 13 88 www.industrial.omron.eu

Austria

Tel: +43 (0) 2236 377 800
www.industrial.omron.at

Belgium

Tel: +32 (0) 2 466 24 80
www.industrial.omron.be

Czech Republic

Tel: +420 234 602 602
www.industrial.omron.cz

Denmark

Tel: +45 43 44 00 11
www.industrial.omron.dk

Finland

Tel: +358 (0) 207 464 200
www.industrial.omron.fi

France

Tel: +33 (0) 1 56 63 70 00
www.industrial.omron.fr

Germany

Tel: +49 (0) 2173 680 00
www.industrial.omron.de

Hungary

Tel: +36 1 399 30 50
www.industrial.omron.hu

Italy

Tel: +39 02 326 81
www.industrial.omron.it

Netherlands

Tel: +31 (0) 23 568 11 00
www.industrial.omron.nl

Norway

Tel: +47 (0) 22 65 75 00
www.industrial.omron.no

Poland

Tel: +48 (0) 22 645 78 60
www.industrial.omron.pl

Portugal

Tel: +351 21 942 94 00
www.industrial.omron.pt

Russia

Tel: +7 495 648 94 50
www.industrial.omron.ru

South-Africa

Tel: +27 (0)11 579 2600
www.industrial.omron.co.za

Spain

Tel: +34 913 777 900
www.industrial.omron.es

Sweden

Tel: +46 (0) 8 632 35 00
www.industrial.omron.se

Switzerland

Tel: +41 (0) 41 748 13 13
www.industrial.omron.ch

Turkey

Tel: +90 216 474 00 40
www.industrial.omron.com.tr

United Kingdom

Tel: +44 (0) 870 752 08 61
www.industrial.omron.co.uk

More Omron representatives
www.industrial.omron.eu

Automation Systems

- Programmable logic controllers (PLC) • Human machine interfaces (HMI) • Remote I/O
- Industrial PC's • Software

Motion & Drives

- Motion controllers • Servo systems • Inverters

Control Components

- Temperature controllers • Power supplies • Timers • Counters • Programmable relays
- Digital panel indicators • Electromechanical relays • Monitoring products • Solid-state relays
- Limit switches • Pushbutton switches • Low voltage switch gear

Sensing & Safety

- Photoelectric sensors • Inductive sensors • Capacitive & pressure sensors
- Cable connectors • Displacement & width-measuring sensors • Vision systems
- Safety networks • Safety sensors • Safety units/relay units • Safety door/guard lock switches