

SAFETY SIMPLIFIED TO THE MAX

Making safety transparent and understandable

In order to implement safety controls, it is essential to begin taking safety into consideration at the design stage. We offer safety systems that incorporate the latest sensing and control technologies combined with safety design, consulting services to ensure optimum machine and equipment safety and secure a safe production environment.



Understand safety in minutes and ask for your own free safety guide at:
<http://industrial.omron.eu/safety>

Safety – Table of contents

Control- and Signalling devices 19

Product overview		432
Selection table		434
Standard pushbutton switches	A16	436
	A22	439
Emergency stop pushbutton switches	A165E	438
	A22E	441
Rope pull emergency stop switches	ER-series rope pulls	442
Signalling devices	LU5	445
	LU7	449
	MP/MPS	452
	LME	454

Safety limit switches 20

Product overview		456
Selection table		459
Safety limit switch with metal housing	D4B	460
Safety limit switch with plastic housing	D4N	462
Safety door hinge switch	D4NH	464
Safety limit switch with manual reset	D4N-_R	465

Safety door switches 21

Product overview		466
Selection table		468
Non-contact switches	F3S-TGR-N_C	470
	F3S-TGR-N_R	473
	F3S-TGR-N_M/-N_U	476
	F3S-TGR-N_X	478
Safety door switches	D4NS	480
	D4BS	481
Guard-lock safety door switch	D4NL	482
	D4GL	483
	D4SL-N	484

Safety sensors 22

Product overview		486
Selection table		488
Type 4 safety light curtain	F3SJ-E	491
	F3SJ-B	495
	F3SJ-A	499
Type 4/2 safety light curtain	MS4800/2800	505
	F3S-TGR-CL	507
Adjustable stands	F39-TGR-AS	512
Muting actuators	F39-TGR-MCL	513
Single-beam safety sensor in compact housing	E3FS	514
Safety laser scanner	OS32C	515

Safety control systems 23

Product overview		518
Selection table		520
Expandable safety relay unit	G9SA	522
Slim-size safety unit	G9SB	523
Safety relays	G9SR	524
Flexible safety unit	G9SX	525
Compact non-contact door switch/flexible safety unit	D40A/G9SX-NS	526
Safety guard switching unit	G9SX-GS/A4EG	528
Limited speed monitoring unit	G9SX-LM	530
Standstill monitoring unit	G9SX-SM	532
Standalone safety controller	G9SP-N_	533
Safety network controller	NE1A-SCPU_	536
DeviceNet safety I/O terminal block family	DST1-ID/-MD/-MRD	537
Relays with forcibly guided contacts	G7SA	539



INTERACT WITH YOUR MACHINE

Patlite Signal towers

Machines that are stopped during production are creating extra cost, our signal towers are used to show this status and guide workers to service the machines efficiently, minimizing downtime and production loss.

- LED technology
- Optional sound system
- 30 mm, 50 mm, 60 mm and 70 mm diameter
- Modular and monolithic systems





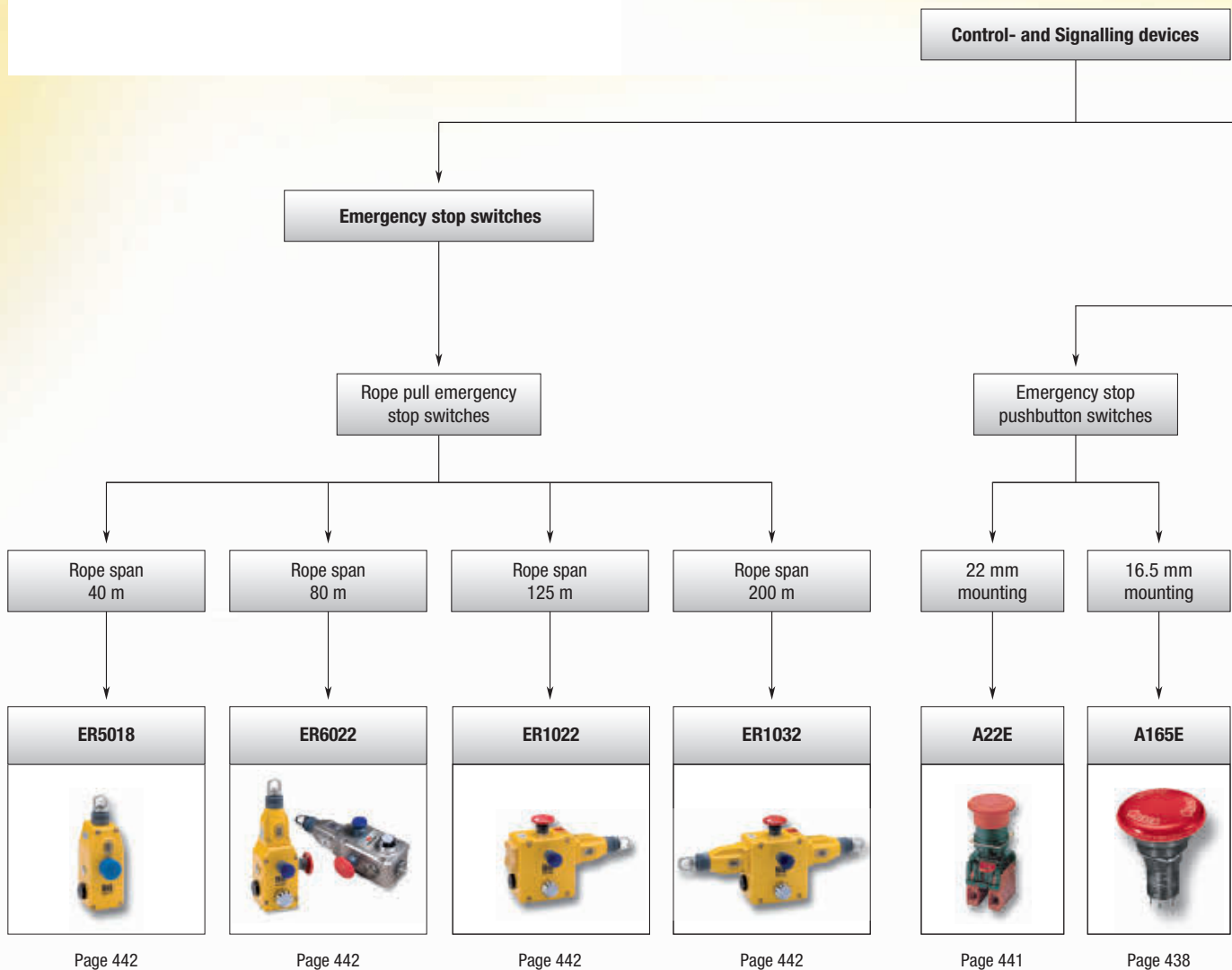

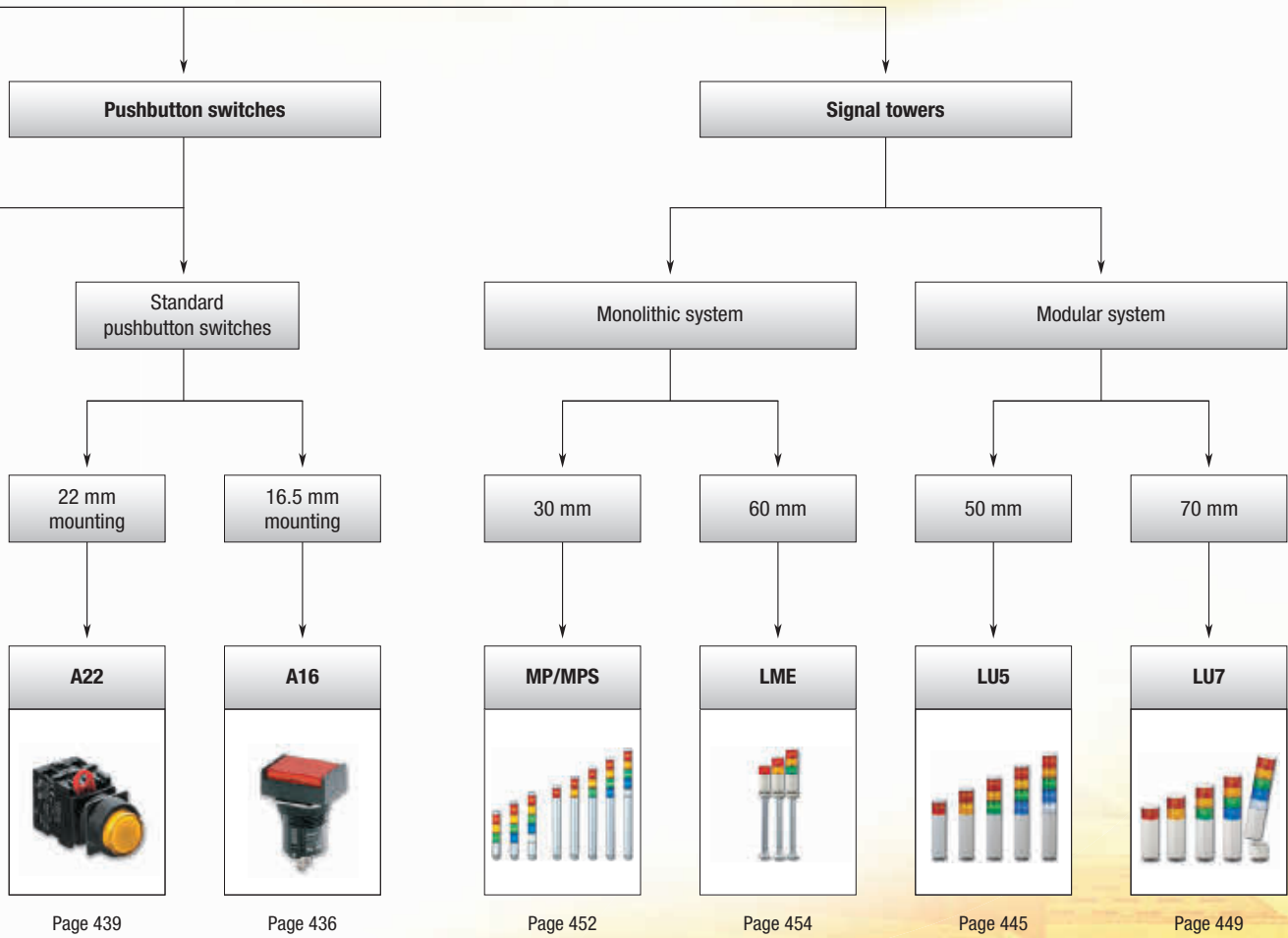

Select your signal tower in a split second:
www.omron-industrial.com/safety





Selection table







		Category	Pushbutton switch	
Selection criteria				
	Model		A16	A22
	Mounting	Nut-mounting		
	Size	16 mm	22 mm	
	Shape			
Pushbutton colour	Incandescent lamp-lighted	Red	■	■
		Yellow	■	■
		Pure yellow	■	
		Green	■	■
	LED-lighted	White	■	■
		Blue	■	■
		Red	■	■
		Yellow	■	■
	Non-lighted	Pure yellow	■	
		Green	■	■
		White	■	■
		Blue	■	■
	Features	Red	■	■
		Yellow	■	■
		Green	■	■
		White	■	■
Switch ratings [A]	Momentary operation	■	■	
	Self-holding	■	■	
	Number of contacts	2	6	
	IP rating	IP65		
Terminals	Legend plate	■	■	
	125 VAC	5	10	
	250 VAC	3	6	
	30 VDC	3	10	
Operating voltage	Rated load	5 A at 125 VAC, 3 A at 250 VAC, 3 A at 30 VDC	10 A at 110 VAC, 6 A at 220 VAC	
	Solder	■	–	
	PCB	–	–	
Form	Screw-less Clamp	–	–	
	5 VDC	■	■	
	12 VDC	■	■	
	24 VDC	■	■	
	SPDT	■	–	
	DPDT	■	–	
	SPST-NO	–	■	
	SPST-NC	–	■	
SPST-NO + SPST-NC	–	■		
Page	DPST-NO	–	■	
	DPST-NC	–	■	
	Page	436	439	

		Emergency stop pushbutton switches	
Selection criteria			
	Model	A165E	A22E
	Housing	Plastic	
	Protection class	IP65	
Features	Operating temperature range	–10 to 55°C	–20 to 70°C
	Head size	30 mm, 40 mm	30 mm, 40 mm, 60 mm
	Conformity	EN 60947-5-1	
	Max. rope span	–	
Application	Conduit size M20	–	
	Additional E-Stop button	–	
	LED indicator beacon	–	
	Stainless steel housing	–	
	Explosion proof housing	–	
	Lighted head	■	
Contact configuration	Push lock – pull reset	–	■
	Push lock – turn reset	■	
	E-Stop application	■	
	General safety application	■	
Page	SPST (NC)	■	
	DPST (NC)	■	
	SPST (NO) + SPST (NC)	–	■
	TPST (NC)	■	–
	Page	438	441

■ Standard

□ Available

– No/not available

		Rope pull switches			
					
		ER 5018	ER 6022	ER 1022	ER 1032
Selection criteria	Model	Metal			
	Housing	IP67			
	Protection class	-25 to 80°C			
	Operating temperature range	-			
	Head size	EN60947-5-1:2004, EN60947-5-5:1997+A1:2005; EN60204-1; EN ISO 13850:2006			
Features	Conformity	40 m	80 m	125 m	200 m
	Max. rope span	■			
	Conduit size M20	■			
	Additional E-Stop button	-	■	■	■
	LED indicator beacon	-	Available	-	-
	Stainless steel housing	-	■	■	■
	Explosion proof housing	-			
	Lighted head	-			
	Push lock – pull reset	-			
	Push lock, turn reset	-			
Application	Push lock, lock key reset	-			
	E-Stop application	■			
Contact configuration	General safety application	■			
	2NC+1NO	■	■	-	-
	3NC	■	■	-	-
	4NC+2NO	-	-	■	■
	Page	442			
		Signalling devices			
					
		MP/MPS	LME	LU5	LU7
System	monolithic	modular			
Diameter	30 mm	60 mm	50 mm	70 mm	
LED technology	■	■	■	■	
Sound system	-	■	■	■	
IP65	■	■	■	■	
Maximum modules	5	5	5	5	
Input voltage 24 VDC	■	■	■	■	
Unit colour	silver	white or silver or black	white or silver	white or silver or black	
Page	452	454	445	449	



16 mm pushbutton switch

These sub-assembled pushbutton switches have a modular construction: pushbutton + case + lamp (if applicable) + switch. A16 is a nut-mounted pushbutton switch with a short mounting depth of less than 28.5mm below panel.

- Wide variety of control and signal devices: lighted, non-lighted and buzzer
- Quick and easy assembly, snap-in switch
- Wide range of switching capacity from standard load to micro load
- High reliability, IP65
- UL, cUL, CSA and VDE approved, conforms to EN60947-5-1 and IEC947-5-1

Ordering information

Type	Colour	Order code		
		Degree of protection: Oil-resistant IP65		
		Rectangular	Square	Round
Non-lighted LED Incandescent lamp	Red	A165L-JR	A165L-AR	A165L-TR
	Yellow	A165L-JY	A165L-AY	A165L-TY
	Pure yellow	A165L-JPY	A165L-APY	A165L-TPY
	White	A165L-JW	A165L-AW	A165L-TW
	Blue	A165L-JA	A165L-AA	A165L-TA
Non-lighted	Black	A165L-JB	A165L-AB	A165L-TB
LED	Green	A165L-TGY	A165L-AGY	A165L-TGY
Non-lighted/incandescent lamp	Green	A165L-JG	A165L-AG	A165L-TG

Cases

Appearance	Classification		Order code	
			Oil-resistant IP65	
	Momentary operation	Rectangular (2-way guard)	A165-CJM	
		Square	A165-CAM	
		Round	A165-CTM	
	Alternate operation	Rectangular (2-way guard)	A165-CJA	
		Square	A165-CAA	
		Round	A165-CTA	

Switches

Appearance	Classification			Order code	
	Lighted/ non-lighted (common use)	Standard load/ microload (common use)	SPDT	Solder terminal	A16-1
			DPDT		A16-2
			SPDT	PCB terminal	A16-1P
			DPDT		A16-2P
			DPDT	Screw- less clamp	A16-2S

Switches with reduced voltage lighting



Appearance	Classification			Order code	
	100 V	Standard load/ microload (common use)	SPDT	Solder terminal	A16-T1-1
			DPDT		A16-T1-2
	100 V		DPDT	Screw-less clamp	A16-T1-2S
	200 V				A16-T2-2S

Lamps

Type	Colour	Order code		
		5 VDC	12 VDC	24 VDC
LED	Red	A16-5DSR	A16-12DSR	A16-24DSR
	Yellow	A16-5DSY	A16-12DSY	A16-24DSY
	Green	A16-5DSG	A16-12DSG	A16-24DSG
	White *1	A16-5DSW	A16-12DSW	A16-24DSW
	Blue	A16-5DA	A16-12DA	A16-24DA
Type		5 VAC/VDC	12 VAC/VDC	24 VAC/VDC
Incandescent lamp		A16-5	A16-12	A16-24

*1 Use the white LED together with white or pure yellow pushbuttons.

Accessories

Name	Appearance	Classification	Remarks	Order code
Switch guards		For rectangular models	Cannot be used with the dust cover	A16ZJ-5050
		For square and round models		A16ZA-5050
Dust covers		For rectangular models	Cannot be used with the switch guard	A16ZJ-5060
		For square models		A16ZA-5060
		For round models		A16ZT-5060
Panel plugs		For rectangular models	Used for covering the panel cutouts for future panel expansion	A16ZJ-3003
		For square models		A16ZA-3003
		For round models		A16ZT-3003

Specifications

Allowable operating frequency	Mechanical	Momentary operation: 120 operations/minute max. Alternate operation: 60 operations/minute max.
	Electrical	20 operations/minute max.
Durability	Mechanical	Momentary operation: 2,000,000 operations min. Alternate operation: 200,000 operations min.
	Electrical	100,000 operations min.
Ambient temperature	Operating: -10 to 55°C (with no icing or condensation) Storage: -25 to 65°C (with no icing or condensation)	
Weight	Approx. 10 g (in the case of a lighted DPDT switch with solder terminals)	
Size in mm (HxWxD)	Round/square: 18x18x28.5 rectangular: 18x24x28.5	

Operating characteristics	Pushbutton switch	
	Oil-resistant IP65	
	SPDT	DPDT
Operating force (OF) max.	2.94 N	4.91 N
Releasing force (RF) min.	0.29 N	
Total travel (TT)	Approx. 3 mm	
Pretravel (PT) max.	2.5 mm	
Lock stroke (LTA) min.	0.5 mm	

Item	Screw-less clamp			
	Twisted wire	0.5 mm ²	0.75 mm ²	1.25 mm ²
Recommended wire size	0.5 mm ² twisted wire or 0.8 mm dia. solid wire			
Usable wires and tensile strength	Twisted wire	0.3 mm ²	0.5 mm ²	0.75 mm ²
	Solid wire	0.5 mm dia.	0.8 mm dia.	1.0 mm dia.
Tensile strength	Twisted wire	10 N	20 N	30 N
	Solid wire	10 N	20 N	40 N
Length of exposed wire	10 ± 1 mm			



Emergency stop switch

The A165E line-up offers E-Stop switches with various head types. For flexible application, a wide range of accessories is provided. To set up easy installation and maintenance, various contact combinations are available.

- Direct opening mechanism with minimum contact separation of 3 mm
- Safety lock mechanism prevents misuse
- Short mounting depth
- Modular construction; easy installation using snap-in switch

Ordering information

Switches	Rated voltage	Pushbutton color	Pushbutton size	Terminal	Contact	Order code Standard load (125 VAC at 5 A, 250 VAC at 3 A, 30 VDC at 3 A)
LED	24 VDC	Red	30 dia.	Solder terminal	SPST-NC	A165E-LS-24D-01
None	–				DPST-NC	A165E-LS-24D-02
LED	24 VDC		40 dia.		SPST-NC	A165E-S-01
					DPST-NC	A165E-S-02
None	–		40 dia.		TPST-NC	A165E-S-03U
					SPST-NC	A165E-LM-24D-01
			DPST-NC		A165E-LM-24D-02	
			SPST-NC		A165E-M-01	
None	–		40 dia.	DPST-NC	A165E-M-02	
				TPST-NC	A165E-M-03U	

Note: The above models have a surface indication of "RESET." Models with "STOP" indication are also available. For further information, contact your Omron representative.

Accessories (order separately)

Item	Type	Precautions	Order code
Yellow plate	Yellow, 45 dia.	Use this as an emergency stop nameplate.	A16Z-5070
Panel plug	Round	Used for covering the panel cutouts for future panel expansion.	A16ZT-3003
Tightening tool	–	Useful for repetitive mounting. Be careful not to tighten excessively.	A16Z-3004
Extractor	–	Convenient for extracting the switch and lamp.	A16Z-5080

Specifications

Rated voltage	Resistive load		Features	Characteristics
	A165E series	A165E_-U series		
125 VAC	5 A	1 A	Operating force (OF) max.	14.7 N
250 VAC	3 A	0.5 A	Releasing force (RF) min.	0.1 N·m
30 VDC	3 A	1 A	Pretravel (PT)	3.5±0.5 mm (3±0.5 mm In case of A165E_U series)
Minimum applicable load	150 mA at 5 VDC	1 mA at 5 VDC		

Item	Emergency stop switch	
Allowable operating frequency	Mechanical	20 operations/minute max.
	Electrical	10 operations/minute max.
Insulation resistance	100 MΩ min. (at 500 VDC)	
Dielectric strength	1,000 VAC, 50/60 Hz for 1 min between terminals of same polarity 2,000 VAC, 50/60 Hz for 1 min between terminals of different polarity and also between each terminal and ground 1,000 VAC, 50/60 Hz for 1 min between lamp terminals ^{*1}	
Durability	Mechanical	100,000 operations min.
	Electrical	100,000 operations min.
Ambient temperature	Operating: -10 to 55°C (with no icing or condensation) Storage: -25 to 65°C (with no icing or condensation)	
Protection against electric shock	Class II	

*1 LED not mounted. Test them with the LED removed.











22 mm pushbutton switch

A22 comes in a wide variety of shapes and colours and is installable in 22-dia. or 25-dia. panel cutouts. The switch unit can easily be mounted. A22 is mounted using either open-type (fork-type) or closed-type (round-type) crimp terminals.

- Finger-protection mechanism on switch unit provided as standard feature
- Increased wiring efficiency with three-row mounting of switch blocks
- IP65 oil-resistant (non-lighted models), IP65 (lighted models)
- Lighted and non-lighted, flat, projection and half- and full-guard versions
- EN60947-5-1, UL and cUL approved

Ordering information

Pushbutton

Illumination	Colour	Order code							
		Flat type	Projection type	Full-guard type	Half-guard type	Square/projection type	Square/full-guard type	Round/mushroom type (30-dia. head)	Round/mushroom type (40-dia. head)
									
Non-lighted	Red	A22-FR	A22-TR	A22-GR	A22-HR	A22-CR	A22-DR	A22-SR	A22-MR
	Green	A22-FG	A22-TG	A22-TG	A22-HG	A22-CG	A22-DG	A22-SG	A22-MG
	Yellow	A22-FY	A22-TY	A22-GY	A22-HY	A22-CY	A22-DY	A22-SY	A22-MY
	White	A22-FW	A22-TW	A22-GW	A22-HW	A22-CW	A22-DW	A22-SW	A22-MW
	Blue	A22-FA	A22-TA	A22-GA	A22-HA	A22-CA	A22-DA	A22-SA	A22-MA
	Black	A22-FB	A22-TB	A22-GB	A22-HB	A22-CB	A22-DB	A22-SB	A22-MB
Lighted	Red	–	A22L-TR	A22L-GR	A22L-HR	A22L-CR	A22L-DR	–	–
	Green	–	A22L-TG	A22L-GG	A22L-HG	A22L-CG	A22L-DG	–	–
	Yellow	–	A22L-TY	A22L-GY	A22L-HY	A22L-CY	A22L-DY	–	–
	White	–	A22L-TW	A22L-GW	A22L-HW	A22L-CW	A22L-DW	–	–
Blue	–	A22L-TA	A22L-GA	A22L-HA	A22L-CA	A22L-DA	–	–	
Buttons size in mm		29.7 dia. x 12D	29.7 dia. x 19D	29.7 dia. x 19D	29.7 dia. x 12/18.5D	29.8 mm ² x 18D	29.8 mm ² x 18D	30 dia. x 32D	40 dia. x 32D

Switches

Switch operation	Contacts	Order code			
		Non-lighted models		Lighted models	
		Without voltage reduction unit		With voltage reduction unit	
				110 VAC	220 VAC
Momentary	SPST-NO	A22-10M	A22L-10M	A22L-10M-T1	A22L-10M-T2
	SPST-NC	A22-01M	A22L-01M	A22L-01M-T1	A22L-01M-T2
	SPST-NO + SPST-NC	A22-11M	A22L-11M	A22L-11M-T1	A22L-11M-T2
	DPST-NO	A22-20M	A22L-20M	A22L-20M-T1	A22L-20M-T2
	DPST-NC	A22-02M	A22L-02M	A22L-02M-T1	A22L-02M-T2
	Alternate	SPST-NO	A22-10A	A22L-10A	A22L-10A-T1
SPST-NC		A22-01A	A22L-01A	A22L-01A-T1	A22L-01A-T2
SPST-NO + SPST-NC		A22-11A	A22L-11A	A22L-11A-T1	A22L-11A-T2
DPST-NO		A22-20A	A22L-20A	A22L-20A-T1	A22L-20A-T2
DPST-NC		A22-02A	A22L-02A	A22L-02A-T1	A22L-02A-T2

Switch blocks

	Standard load	Order code
Switch blocks	SPST-NO	A22-10
	SPST-NC	A22-01
	DPST-NO	A22-20
	DPST-NC	A22-02

Lamp – LED

AC/DC	LED light	Order code			
		Operating voltage			
		6 V	12 V	24 V	24 V superbright
DC	Red	A22-6DR	–	–	–
	Green	A22-6DG	–	–	–
	Yellow ^{*1}	A22-6DY	–	–	–
	Blue	A22-6DA	–	–	–
AC	Red	A22-6AR	–	–	–
	Green	A22-6AG	–	–	–
	Yellow ^{*1}	A22-6AY	–	–	–
	Blue	A22-6AA	–	–	–
AC and DC	Red	–	A22-12AR	A22-24AR	A22-24ASR
	Green	–	A22-12AG	A22-24AG	A22-24ASG
	Yellow ^{*1}	–	A22-12AY	A22-24AY	A22-24ASY
	Blue	–	A22-12AA	A22-24AA	A22-24ASA

^{*1} Used when the pushbutton colour is yellow or white

Lamp - incandescent lamp

Order code		
Operating voltage		
5 VAC/VDC	12 VAC/VDC	24 VAC/VDC
A22-5	A22-12	A22-24

Accessories

Item			Remarks	Order code
Lamp sockets	Direct lighting		Used when changing the lighting method (LED only)	A22-TN
	Voltage-reduction lighting			220 VAC
Mounting latches	For momentary models		Order mounting latches only when mounting switch blocks or lamp sockets are purchased individually	A22-3200
Legend plate frames	Large size	With snap-in legend plate, without text, black	Snap-in legend plate is acrylic	A22Z-3333
		Without snap-in legend plate		A22Z-3330
Sealing caps	For projection models		Used to prevent dust or water from entering the operation unit (pushbutton, etc.), colour: Opaque, material: Silicon	A22Z-3600T
Three-throw spacer			Used when mounting three non-lighted switches	A22Z-3003
Control boxes (enclosures)	Exclusively for A22		One hole	A22Z-B101
			Two holes	A22Z-B102
			Three holes	A22Z-B103
Snap-in legend plates	Standard size	Without text	White	A22Z-3443W
			Transparent	A22Z-3443C
			White text on black background	ON
		OFF	A22Z-3443B-6	
		DOWN	A22Z-3443B-8	
		POWER ON	A22Z-3443B-9	
	Large size	Without text	White	A22Z-3453W
			Transparent	A22Z-3453C
	For emergency stop switch	60-dia. round plate with black letters on a yellow background	"EMERGENCY STOP" is engraved on the plate.	
90-dia. round plate with black letters on a yellow background		Used as an emergency stop switch legend plate		A22Z-3476-1
Lamp extractor			Rubber tool used to easily replace lamps	A22Z-3901
Tightening wrench			Tool used to tighten nuts from the back of the panel	A22Z-3905

Specifications

Recognized organization	Standards	File number
UL, cUL	UL508	E41515
—	EN60947-5-1	—

Contact ratings (standard load)

Rated carry current (A)	Rated voltage	Rated current (A)			
		AC15 (inductive load)	AC12 (resistive load)	DC13 (inductive load)	DC12 (resistive load)
10	24 VAC	10	10	—	—
	110 VAC	5	10	—	—
	220 VAC	3	6	—	—
	380 VAC	2	3	—	—
	440 VAC	1	2	—	—
	24 VDC	—	—	1,5	10
	110 VDC	—	—	0,5	2
	220 VDC	—	—	0,2	0,6
	380 VDC	—	—	0,1	0,2

Contacts (microload)

Rated applicable load	Minimum applicable load
50 mA at 5 VDC (resistive load)	1 mA at 5 VDC

LED indicators without voltage reduction unit

Rated voltage	Rated current	Operating voltage
6 VDC	60 mA (20 mA)	6 VDC ±5%
6 VAC	60 mA (20 mA)	6 VAC/VDC ±5%
12 VAC/VDC	30 mA (10 mA)	12 VAC/VDC ±5%
24 VAC/VDC	15 mA (10 mA)	24 VAC/VDC ±5%

Super-bright LED indicator

Rated voltage	Rated current	Operating voltage
24 VAC/VDC	15 mA	24 VAC/VDC ±5%

Incandescent lamp

Rated voltage	Rated current	Operating voltage
6 VAC/VDC	200 mA	5 VAC/VDC
14 VAC/VDC	80 mA	12 VAC/VDC
28 VAC/VDC	40 mA	24 VAC/VDC
130 VAC/VDC	20 mA	100 VAC/VDC

Voltage-reduction lighting

Rated voltage	Operating voltage	Applicable lamp (BA8S/13_gold)
110 VAC	95 to 115 VAC	LED Lamp (A22-24A_)
220 VAC	190 to 230 VAC	

Item	Pushbutton switches		Emergency stop switches		Knob-type selector switches		Key-type selector switch
	Non-lighted	Lighted	Non-lighted	Lighted	Non-lighted	Lighted	Non-lighted
Allowable operating frequency	Mechanical	Momentary operation: 60 operations/minute max.	30 operations/minute max.		Manual release: 30 operations/minute max., automatic release: 30 operations/minute max.		
	Electrical	30 operations/minute max.		30 operations/minute max.			
Durability (number of operations min.)	Mechanical	Momentary operation: 5,000,000		Momentary operation: 300,000		500,000	100,000
	Electrical	500,000		300,000		500,000	100,000
Ambient temperature	Operating	-20 to 70°C	-20 to 55°C	-20 to 70°C	-20 to 55°C	-20 to 70°C	-20 to 70°C
	Storage	-40 to 70°C	-40 to 70°C	-40 to 70°C	-40 to 70°C	-40 to 70°C	-40 to 70°C
Degree of protection	IP65 (oil-resistant)	IP65	IP65 (oil-resistant)	IP65	IP65 (oil-resistant)	IP65	IP65 (oil-resistant)
Size in mm (in-panel only)	34Hx34Wx54.7D, 34Hx34Wx72.7D for DPST switches						



Emergency stop switch

The A22E line-up of E-Stop switches offers various head types as well as lighted models. E-stop shrouds and control boxes as accessories provide flexibility in application.

- Direct opening mechanism with minimum contact separation of 3 mm
- Safety lock mechanism prevents misuse
- Easy mounting of switch block
- Lighted models for easy diagnosis and maintenance
- Modular design for flexibility in application

Ordering Information

Non-lighted models

Description	Output	Color of cap	Order code
30-dia. head Push-lock Turn-reset	SPST-NC	Red	A22E-S-01
	SPST-NO/SPST-NC		A22E-S-11
	DPST-NC		A22E-S-02
40-dia. head Push-lock Turn-reset	SPST-NC		A22E-M-01
	SPST-NO/SPST-NC		A22E-M-11
	DPST-NC		A22E-M-02
60-dia. head Push-lock Turn-reset	SPST-NC		A22E-L-01
	SPST-NO/SPST-NC		A22E-L-11
	DPST-NC		A22E-L-02

Lighted models

Description	Output	Lighting	Rated voltage	Color of cap	Order code
40-dia. head Push-lock Turn-reset	SPST-NC	LED	24 VAC/VDC	Red	A22EL-M-24A-01
	SPST-NO/SPST-NC		24 VAC/VDC		A22EL-M-24A-11
	DPST-NC		24 VAC/VDC		A22EL-M-24A-02
40-dia. head Push-lock Turn-reset	SPST-NC		220 VAC		A22EL-M-T2-01
	SPST-NO/SPST-NC		220 VAC		A22EL-M-T2-11
	DPST-NC		220 VAC		A22EL-M-T2-02

Accessories (Order separately)

Item	Classification	Remarks	Order code
Control boxes (enclosures)	One hole	Material: Polycarbonate resin	A22Z-B101
	One hole, yellow box (for emergency stop)		A22Z-B101Y
	Two holes		A22Z-B102
	Three holes		A22Z-B103
Legend plates for emergency stop	60-dia. black letters on yellow back-ground	"EMERGENCY STOP" is indicated on the plate.	A22Z-3466-1
	90-dia. black letters on yellow back-ground		A22Z-3476-1

Specifications

Contacts (standard load)

Rated carry current	Rated voltage	Rated current (A)			
		AC15	AC12	DC13	DC12
10	24 VAC	10	10	---	---
	220 VAC	3	6	---	---
	24 VDC	---	---	1.5	10
	220 VDC	---	---	0.2	0.6

Note: 1. Rated current values are determined according to the testing conditions. The above ratings were obtained by conducting tests under the following conditions.
 (1) Ambient temperature: 20±2°C
 (2) Ambient humidity: 65±5%
 (3) Operating frequency: 20 operations/minute
 2. Minimum applicable load: 10 mA at 5 VDC

Contacts (microload)

Rated applicable load	Minimum applicable load
50 mA at 5 VDC (resistive load)	1 mA at 5 VDC

Characteristics

Item	Emergency stop switches	
	Non-lighted model: A22E	Lighted model: A22EL
Dielectric strength	2,500 VAC, 50/60 Hz for 1 min between terminals of same polarity 2,500 VAC, 50/60 Hz for 1 min between terminals of different polarity and also between each terminal and ground	
Durability	Mechanical	Momentary operation: 300,000 operations min.
	Electrical	300,000 operations min.
Degree of protection	IP65 (oil-resistant)	IP65



Emergency stop switch

- Tension indicator – the tension indicator makes the system easy to set up and to maintain the proper rope tension
- Heavy-duty housing – the die-cast housing and stainless steel eye nut makes the ER-series rope pull switches suitable for demanding industrial applications
- Vibration tolerant – the snap-acting switch contacts protect against nuisance tripping due to vibration
- Integral E-stop – the E-stop button provides emergency stopping capability at the extreme end of the installation and is field serviceable
- ER6022 available in stainless steel housing
- ER6022, ER1022 and ER1032 available in explosion proof housing

Ordering information

Standard models

Aluminium die-cast housing

E-Stop	Indicator beacon	Contacts	Wiring entry	Order code
Not included	–	2 N/C + 1 N/O	3 × M20	44506-4010 ER5018-021M
Not included	–	3 N/C	3 × M20	44506-4030 ER5018-030M
Included	–	2 N/C + 1 N/O	3 × M20	44506-4110 ER5018-021ME
Included	–	3 N/C	3 × M20	44506-4130 ER5018-030ME
Not included	Not included	2 N/C + 1 N/O	3 × M20	44506-5010 ER6022-021M
Not included	Not included	3 N/C + 1 N/O	3 × M20	44506-5050 ER6022-031M
Not included	Included (24 VDC)	2 N/C + 1 N/O	3 × M20	44506-5110 ER6022-021ML
Not included	Included (24 VDC)	3 N/C + 1 N/O	3 × M20	44506-5150 ER6022-031ML
Included	Not included	2 N/C + 1 N/O	3 × M20	44506-5210 ER6022-021ME
Included	Not included	3 N/C + 1 N/O	3 × M20	44506-5250 ER6022-031ME
Included	Included (24 VDC)	2 N/C + 1 N/O	3 × M20	44506-5410 ER6022-021MEL
Included	Included (24 VDC)	3 N/C + 1 N/O	3 × M20	44506-5450 ER6022-031MEL
Included	Included (24 VDC)	4 N/C + 2 N/O	4 × M20	44506-6410 ER1022-042MELL
Included	Included (24 VDC)	4 N/C + 2 N/O	4 × M20	44506-6510 ER1022-042MELR
Included	Included (24 VDC)	4 N/C + 2 N/O	4 × M20	44506-7410 ER1032-042MEL

Stainless steel housing

E-Stop	Indicator beacon	Contacts	Wiring entry	Order code
Not included	Not included	2 N/C + 2 N/O	3 × M20	44506-5810 ER6022-022MSS
Not included	Not included	3 N/C + 1 N/O	3 × M20	44506-5830 ER6022-031MSS
Not included	Included	2 N/C + 2 N/O	3 × M20	44506-5910 ER6022-022MLSS
Not included	Included	3 N/C + 1 N/O	3 × M20	44506-5930 ER6022-031MLSS
Included	Not included	2 N/C + 2 N/O	3 × M20	44506-5850 ER6022-022MESS
Included	Not included	3 N/C + 1 N/O	3 × M20	44506-5870 ER6022-031MESS
Included	Included	2 N/C + 2 N/O	3 × M20	44506-5950 ER6022-022MELSS
Included	Included	3 N/C + 1 N/O	3 × M20	44506-5970 ER6022-031MELSS

Explosion proof models

Aluminium die-cast housing

E-Stop	Indicator beacon	Contacts	Wiring entry	Order code
Not included	Not included	1 N/C + 1 N/O	pre-wired, 3 m	44506-5600 XER6022-011C3
Not included	Not included	1 N/C + 1 N/O	pre-wired, 3 m	44506-6600 XER1022-011C3L
Not included	Not included	1 N/C + 1 N/O	pre-wired, 3 m	44506-6610 XER1022-011C3R
Not included	Not included	1 N/C + 1 N/O	pre-wired, 3 m	44506-7600 XER1032-011C3

Stainless steel housing

E-Stop	Indicator beacon	Contacts	Wiring entry	Order code
Not included	Not included	1 N/C + 1 N/O	pre-wired, 3 m	44506-5610 XER6022-011C3SS
Not included	Not included	2 N/C	pre-wired, 3 m	44506-5620 XER6022-020C3SS

Accessories

Item	Applicable model	Order code
Replacement Lid	ER5018	44506-3700 SM06-SL400
	ER6022	44506-5700 SM06-SL500
	ER6022-SS stainless steel	44506-5730 SM06-SLXER6022SS
Replacement Lid/LED, 24 VDC	ER1022	44506-6710 SM06-SL710
	ER1032	44506-7710 SM06-SL711
	ER6022-SS stainless steel	44506-5740 SLER6022LSS
Replacement Lid/LED	ER6022	44506-5710 SM06-SL510
Rope kit, 5 m, stainless steel	ER5018, ER6022, ER1022, ER1032	44506-2705 RK5
Rope kit, 10 m, stainless steel	ER5018, ER6022, ER1022, ER1032	44506-2710 RK10
Rope kit, 20 m, stainless steel	ER5018, ER6022, ER1022, ER1032	44506-2720 RK20
Rope kit, 50 m, stainless steel	ER5018, ER6022, ER1022, ER1032	44506-2750 RK50
Rope kit, 80 m, stainless steel	ER6022, ER1022, ER1032	44506-2780 RK80
Rope kit 100 m, stainless steel	ER6022, ER1022, ER1032	44506-2711 RK100
Rope kit 126 m, stainless steel	ER1032	44506-2726 RK126
Rope only, 5 m	ER5018, ER6022, ER1022, ER1032	44506-3705 R5M
Rope only, 10 m	ER5018, ER6022, ER1022, ER1032	44506-3710 R10M
Rope only, 20 m	ER5018, ER6022, ER1022, ER1032	44506-3720 R20M
Rope only, 50 m	ER5018, ER6022, ER1022, ER1032	44506-3750 R50M
Rope only, 100 m	ER5018, ER6022, ER1022, ER1032	44506-3711 R100M
Rope only, 126 m	ER5018, ER6022, ER1022, ER1032	44506-3726 R126M
Tensioner gripper, stainless steel	ER5018, ER6022, ER1022, ER1032	44506-4700 SM06-TG00
Eye bolt stainless steel, 8 per pack	ER5018, ER6022, ER1022, ER1032	44506-4710 SM06-EB10
Double loop clip, stainless steel, 4 per pack	ER5018, ER6022, ER1022, ER1032	44506-4720 SM06-DL20
Thimble stainless steel, 4 per pack	ER5018, ER6022, ER1022, ER1032	44506-4770 SM06-THSS
Turnbuckle, stainless steel	ER5018, ER6022, ER1022, ER1032	44506-4730 SM06-TB30
Spring, stainless steel	ER5018, ER6022, ER1022, ER1032	44506-4750 SM06-SP50
Rope pulley, stainless steel	ER5018, ER6022, ER1022, ER1032	44506-4780 SM06-RPSS
E-Stop mechanism	ER5018, ER6022, ER1022, ER1032	44506-4760 SM06-ES60
Yellow E-Stop Background Label	ER5018, ER6022, ER1022, ER1032	44506-4791 SM06-YLES

Specifications

Standard models

Item	Applicable model						
	ER5018	ER6022	ER6022SS	ER1022	ER1032		
Electrical	Contact configurations	2 N/C + 1 N/O, 3 N/C	2 N/C + 1 N/O, 3N/C + 1N/O	3 N/C+1 N/O, 2 N/C+2 N/O	4 N/C + 2 N/O	4 N/C + 2 N/O	
	Safety contacts	2 N/C, 3 N/C	2 N/C, 3 N/C		4 N/C		
	Switching ability	AC: 120 V–6 A, 240 V–3 A, inductive DC: 24 V–2.5 A, inductive					
	Auxiliary contacts	1 N/O		1 N/O, 2 N/O	2 N/O		
	Max. switching current/Volt/Amp	240 V/720 VA					
	Electrical life	1,000,000 minimum					
	LED indicator beacon	–	24 VDC				
Mechanical	Max. rope span	40 m	80 m	100 m	125 m	125 m each side	
	Case material	Die-cast aluminum alloy		Die-cast 316 stainless steel casing	Die-cast aluminum alloy		
	Eye nut material	Stainless steel					
	Wiring entry	3 × M20			4 × M20		
	Mechanical life	1,000,000 minimum					
Environ-mental	Protection	IP67 (NEMA 6)					
	Operating temperature	–25 to 80°C					
	Cleaning	Water washdown					
Com-pliance	Standards	EN60947-5-1:2004, EN60947-5-5:1997+A1:2005; EN60204-1; EN ISO 13850:2006					
	Approvals/listings	CE marked for all applicable directives, UL and C-UL					

Explosion proof models

Item	Applicable model			
	XER6022	XER1022	XER1032	
Electrical	Contact configuration	1 N/C + 1 N/O, 2 N/C		
	Safety contact	1 N/C, 2 N/C		
	Auxiliary contact	1 N/O		
	Rated voltage and current (AC15)	400 VAC/2 A AC, 250 VAC/4 A AC		
	Rated voltage and current (DC)	250 VDC/0.15 A DC		
	Switching ability	Resistive load	125 VAC/5 A, 250 VAC/5 A	
		Inductive load	125 VAC/3 A, 250 VAC/3 A	
	Switching ability	Resistive load	30 VDC/7 A, 250 VDC/0.15 A	
		Inductive load	30 VDC/5 A, 250 VDC/0.03 A	
Com-pliance	Ex-classification	II 2 G EEx d II C T6		
	Certification	PTB00 ATEX 1093X IBExU 01 ATEX 1007X		

Accessories

RK rope tension kit



The RK rope tension kit comes with all of the required hardware for most installations. A spring is required as shown in the installation example below.

Installation Hardware

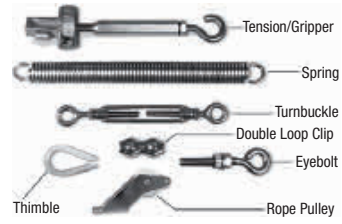

Individual hardware items may be purchased for specific installation requirements.

PATLITE distributed by Omron

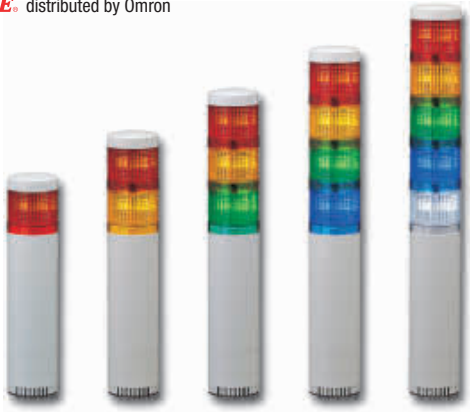

Versatile modular signal tower featuring easy assembly and wiring designed for every need.

LU5 Series - Medium size modular system provides hybrid prism cut lens for enhanced visibility from any direction and distance and two selectable sound patterns up to 85 dB. Main features are the interchangeable LED modules and the color coordinated wiring for easy alignment.

- Diameter: 50 mm
- Base modules available in ivory white or in silver
- Up to 5 LED modules can be used on the light tower
- Modules of the same color operate from different terminals
- Two, user - selectable, alarms integrated in the base module with adjustable volume up to 85 dB at 1 m

Ordering information

LED module

LU5-E-R
1 2

1. E: LED unit
2. Color of LED
R: Red
Y: Yellow
G: Green
B: Blue
C: Clear/White

Base module

LU5-02UB
1 2 3

1. Rated voltage
02: 24 VDC
2. Unit color
Blank: Ivory white
U: Silver color
3. Type
Blank: Continuous light
FB: Continuous or flashing light with audible alarm

Ordering information

LED module

Module color	Power consumption	Rated voltage	Operation voltage	Operation temperature range	Mass	Order code
Red	52 mA/1.25 W	24 VDC	Rated voltage ±10% (21.6~26.4 V)	-30°C~+60°C	44 g ±10%	LU5-E-R
Yellow						LU5-E-Y
Green	42 mA/1.0 W					LU5-E-G
Blue						LU5-E-B
Clear						LU5-E-C

Base module

Typ	Alarm/Flash	Power consumption	Rated voltage	Operation voltage	Operation temperature range	Mass	Open collector	Order code
Standard body	Continuous	1.2 W	24 VDC	Rated voltage ±10% (21.6 ~ 26.4 V)	-30°C~+60°C	182g ±10%	PNP/ NPN	LU5-02*
	2 Sounds/Flashlight							200g ±10%

* Ivory white: black, silver: add "U"

Optional parts

Typ	Material	Order code
Wall mount bracket	Aluminum alloy die-cast	SZ-017
	ABS resin	SZ-020
Upper bracket	Metal	SZ-60NPT
		SZ-60U
Mount bracket	Aluminum alloy die-cast	SZ-016A
		SZ-70B

Typ	Height	Material	Order code
Pole	100 mm	Aluminium	Pole-100A21
	300 mm	Aluminium	Pole-300A21
	800 mm	Aluminium	Pole-800A21

Features



LED module is stackable and reconfigurable even after installation

IP 65: Implemented o rings seal out liquids so that the tower can be used in wet conditions.

Dimensions

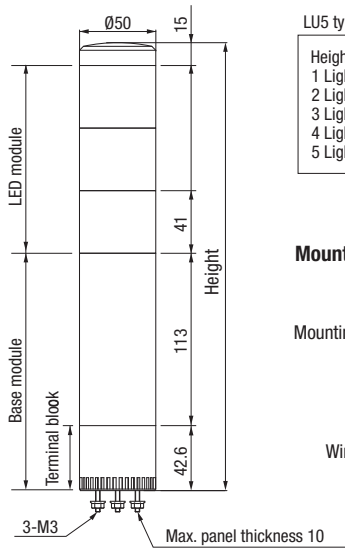

LU5 type

Height (mm)	
1 Light:	211
2 Lights:	252
3 Lights:	293
4 Lights:	334
5 Lights:	375

Mounting dimension

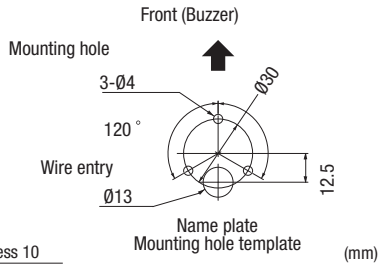

Wiring diagram

LU5-02FB
24 VDC

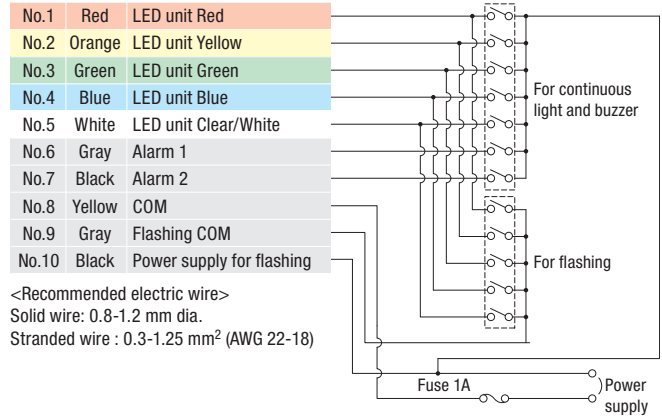

How to order

LED units



Model	LU5-E-R	LU5-E-Y	LU5-E-G	LU5-E-B	LU5-E-C
Unit color	●	●	●	●	○
Rated voltage	24 VDC				
Operating voltage range	Rated voltage±10% (21.6~26.4 V)				
Current/power consumption	52 mA/1.25 W		42 mA/1.0 W		
Operating temperature range	-30°C~+60°C				
Mass	44 g±10%				

● RED
● YELLOW
● GREEN
● BLUE
○ CLEAR/WHITE

BASE units



Model	LU5-02	LU5-02FB	
Color		○	●
Standard body/short body	Standard		
Rated voltage	24 VDC		
Operating voltage range	Rated voltage±10%(21.6~26.4 V)		
Buzzer	-	*Buzzer 1	**Buzzer 2
Current consumption	-	50±10 mA	24±10 mA
Power consumption	-	1.2±0.25 W	0.58±0.25 W
Sound level	-	Max: 85±5 dB (at 1 m)	
Flashing cycle	-	6±12 flashes per minutes	
Operating temperature Range	-30°C~+60°C		
Mounting direction	Upright, indoor only		
Protection rating	IP65		
Mass	182 g±10%	200 g±10%	
Open collector	PNP/NPN		

* Buzzer 1: Continuous sound **Buzzer 2: Intermittent sound

○ Ivory white
● Silver color (U)

Optional parts



Optional parts

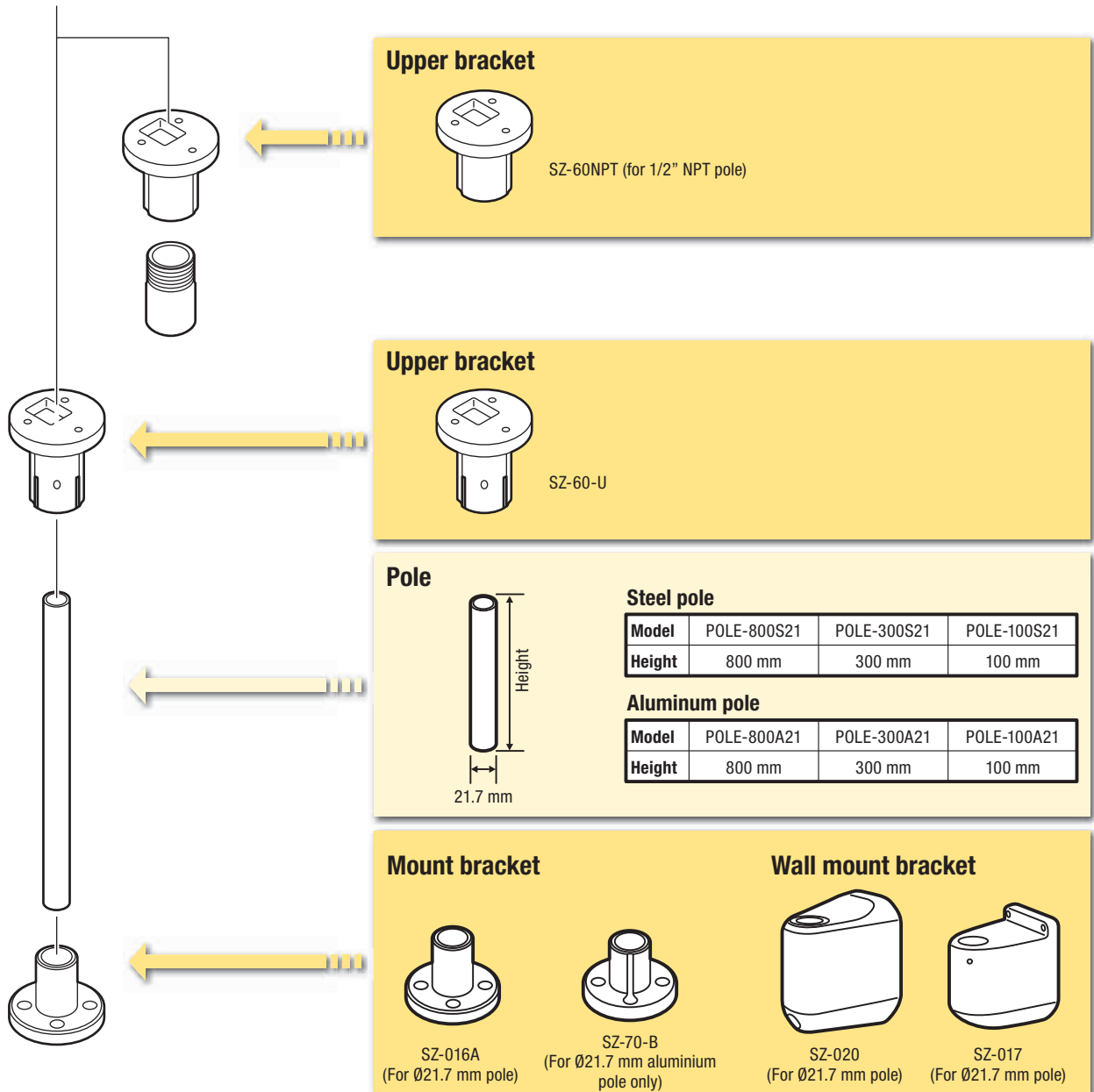

Specifications

Size	50 mm diameter
Input voltage options	24 VDC
Functions available	<ul style="list-style-type: none"> • Continuous only • Continuous, flashing, alarms
Mounting options	Direct mount only, includes 3 mounting nuts
Body styles	<ul style="list-style-type: none"> • Component style, wiring terminals provided • Interchangeable and stackable after purchase
Body colours	Beige
Tiers	1-5 modules can be stacked
Module colors	Red / Yellow / Green / Blue / Clear
Alarms (FB style only)	<ul style="list-style-type: none"> • Alarm 1: selectable, single-tone, continuous alarm, 85 dB (at 1 m) • Alarm 2: selectable, single tone, intermittent (slow beep) alarm, 85 dB (at 1 m)
Ratings	<ul style="list-style-type: none"> • CE • UL listed (US) • UL listed (Canada) • RoHS
Protection	<ul style="list-style-type: none"> • IP-65 • Type 4 / 4X / 13 (indoor only)
Control options	<ul style="list-style-type: none"> • Dry contact closure such as switches or relay contacts • Open-collector transistor (NPN or PNP) for 24 VDC • Direct voltage control for 24 VDC, continuous and alarm functions only

PATLITE distributed by Omron



Versatile modular signal tower featuring easy assembly and wiring designed for every need.

LU7 presents ultra bright LEDs combined with an innovative prism lens design. 1 to 5 modules can be arranged in tiers.

- Diameter: 70 mm
- Base module in 2 sizes and 3 colors
- Different modules: standard LED, strobe LED and sound
- Two, user - selectable, alarms integrated in the base module with adjustable volume up to 90 dB at 1 m.
- Color-coordinated and spring-loaded terminal block

Ordering information

LED module

Typ	Module color	Power consumption	Rated voltage	Operation voltage	Operation temperature range	Mass	Order code
Standard	Red	52 mA/1.25 W	24 VDC	Rated voltage ±10% (21.6~26.4 V)	-30°C~+60°C	60 g ±10%	LU7-E-R
	Yellow						LU7-E-Y
	Green	42 mA/1.0 W					LU7-E-G
	Blue						LU7-E-B
	Clear/White						LU7-E-C
Strobe	Red	290 mA	24 VDC	Rated voltage ±10% (21.6~26.4 V)	-30°C~+60°C	0,07 kg	LU7-XE-R
	Yellow	140 mA					LU7-XE-Y
	Green						LU7-XE-G
	Blue						270 mA
	Clear/White	280 mA					LU7-XE-C

Base module

Typ	Alarm/Flash	Power consumption	Rated voltage	Operation voltage	Operation temperature range	Mass	Open collector	Order code
Short body	Continuous	1.2 W	24 VDC	Rated voltage ± 10% (21.6~26.4 V)	-30°C~+60°C	150 g ±10%	PNP/ NPN	LU7-02S*
Standard body	Continuous					250 g ±10%		LU7 - 02*
	2 Sounds/Flashlight					280 g ±10%		LU7 -02FB*

* Ivory white: blank, black: add "K", silver: add "U"

Optional parts

Typ	Material	Order code
Wall mount bracket	Aluminum alloy die-cast	SZ-017
	PBT/ ABS resin	SZ-018
		SZ-018U
		SZ-018K
	ABS resin	SZ-020
Upper bracket	Metal	SZ - 50U
		SZ - 50UU
		SZ - 50KU
		SZ - 50NPT
Mount bracket	Aluminum alloy die-cast	SZ-016A
		SZ-70B

Typ	Height	Material	Order code
Pole	100 mm	Aluminium	Pole-100A21
		Steel	Pole-100S21
	300 mm	Aluminium	Pole-300A21
		Steel	Pole-300S21
	800 mm	Aluminium	Pole-800A21
		Steel	Pole-800S21

Voice and sound module (unique sound module in all directions)

Rated voltage	Power consumption	Mass	Order code
24 VDC	3.5 W	0.17 kg	LU7-V1

Features

Easy alignment:
Color-coordinated terminal block:
Corresponds to the lens colors for quick wiring verification in the base unit.

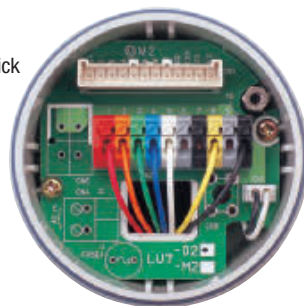

LU7-02FB

LU7 Standard body

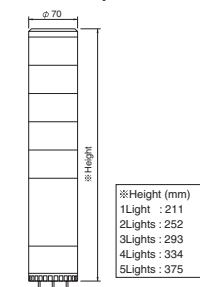

LU7-02S Short body

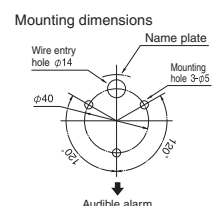
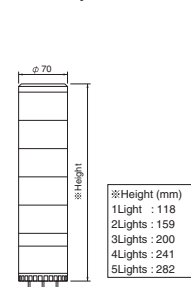

How to order





Voice and sound module



Model	LU7-V1
Type	Voice synthesizer
Rated voltage	24 VDC
Power consumption	3.5 W
Weight	0.17 kg





LED units







Model	LU7-E-R	LU7-E-Y	LU7-E-G	LU7-E-B	LU7-E-C
Unit color					
Rated voltage	24 VDC				
Operating voltage range	Rated voltage±10% (21.6~26.4 V)				
Current/power consumption	52 mA/1.25 W		42 mA/1.0 W		
Operating temperature range	-30°C~+60°C				
Mass	60 g±10%				



LED strobe module





Model	LU7-XE-R	LU7-XE-Y	LU7-XE-G	LU7-XE-B	LU7-XE-C
Unit color					
Rated voltage	24 VDC				
Power consumption	290 mA	290 mA	140 mA	270 mA	280 mA
Mass	0.07 kg				



 RED
  YELLOW
  GREEN
  BLUE
  CLEAR/WHITE

BASE units

Model	LU7-02S	LU7-02	LU7-02FB
Color		  	
Standard body/short body	Short	Standard	
Rated voltage	24 VDC		
Operating voltage range	Rated voltage±10% (21.6~26.4 V)		
Buzzer	-		*Buzzer 1 **Buzzer 2
Current consumption	-		50±10 mA ; 24±10 mA
Power Consumption	-		1.2±0.25 W ; 0.58±0.25 W
Sound level	-		Max: 90±5d B (at 1 m) Min: 70 dB or Less (at 1 m)
Flashing cycle	-		60±12 flashes per minute
Operating temperature Range	-30°C~+60°C		
Mounting direction	Upright, indoor only		
Protection rating	IP65		
Mass	150 g±10%	250 g±10%	280 g±10%
Open collector	PNP/NPN		

* Buzzer 1: Continuous sound **Buzzer 2: Intermittent sound

 Ivory white
  Silver color (U)
  Black (K)

Optional parts

Optional parts

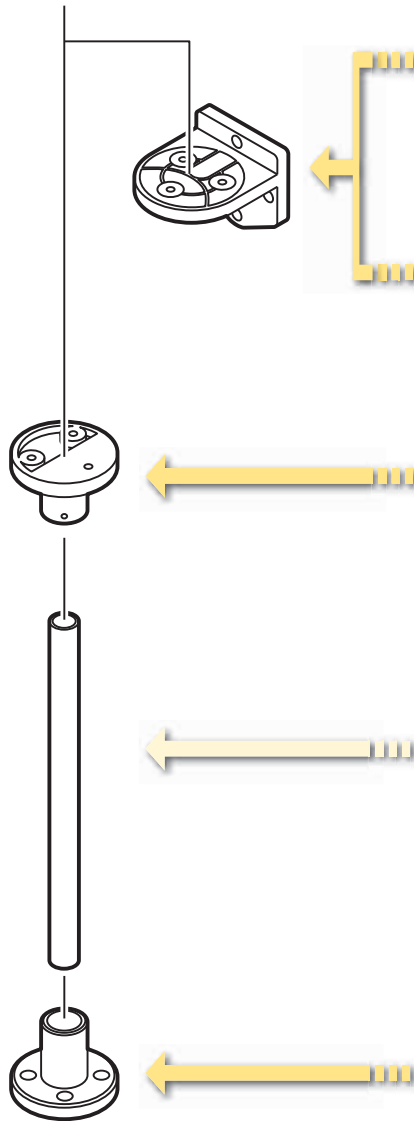

Wall mount bracket

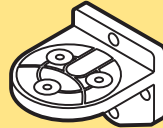

Model	SZ-18	SZ-18U	SZ-18K
Color	Ivory white	Silver color (U)	Black (K)

Upper bracket



SZ-50NPT(For 1/2" NPT pole)

Upper bracket



Model	SZ-50-U	SZ-50U-U	SZ-50K-U
Color	Ivory white	Silver color (U)	Black (K)

Pole



Steel pole

Model	POLE-800S21	POLE-300S21	POLE-100S21
Height	800 mm	300 mm	100 mm

Aluminum pole

Model	POLE-800A21	POLE-300A21	POLE-100A21
Height	800 mm	300 mm	100 mm

Mount bracket

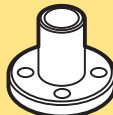

SZ-016A
(For Ø21.7 mm pole)



SZ-70-B
(For Ø21.7 mm Aluminium pole only)

Wall mount bracket



SZ-020
(For Ø21.7 mm pole)



SZ-017
(For Ø21.7 mm pole)

Specifications

Size	70 mm diameter
Input voltage options	• 24 VDC
Functions available	• Continuous only • Continuous, flashing, alarms
Mounting options	Direct mount only: includes three mounting nuts
Body style	• Component style, wiring terminals provided • Interchangeable and stackable after purchase
Body color	• Beige • Black • Silver
Tiers	1-5 modules can be stacked
Module colors	• Red / Yellow / Green / Blue / Clear • Standard LED modules • Strobe-flash LED modules (24 V bases only)
Alarms (FB style only)	• Alarm 1: selectable, single-tone, continuous alarm, 90 dB (at 1 m) • Alarm 2: selectable, single tone, intermittent (slow beep) alarm, 90 dB (at 1 m)
Ratings	• CE • UL listed (US) • UL listed (Canada) • RoHS
Protections	• IP-65 • Type 4/4X/13 (indoor only)
Control options	• Dry contact closure such as switches or relay contacts • Open-collector transistor (NPN or PNP for 24 VDC) • Direct voltage control for 24 VDC, continuous and alarm functions only

PATLITE distributed by Omron

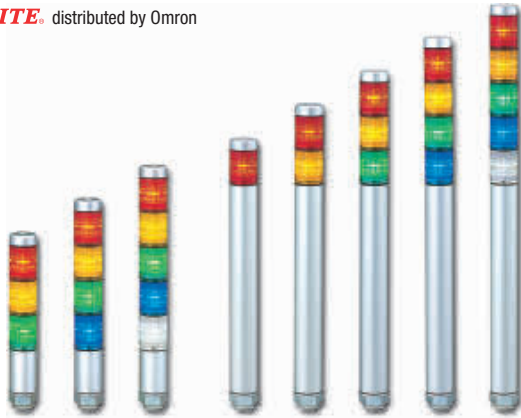

Super slim 30 mm silver body signal tower ideal for small devices

MP/MPS signal towers provide double insulation and superior UV and light translucent AS resin lenses for enhanced durability and reliability in the application environment. The 30mm diameter is ideal for small and mid-sized machines.

Up to 5 colored modules can be combined using a single mounting hole. Modules can be easily added without dismantling the whole signal tower to reduce installation effort.

- Special pre-wired versatile with 1 connection cable
- NPN/ PNP compactible
- IP65
- Each color of LED module corresponds to the lead wire color.
- Available colors are Red, Yellow, Green, Blue and Clear/White. All colors as clear-lens modules available

Ordering information

MP-502-RYGBC-B0738
 1 2 3 4 5

- | | | |
|---|--|---|
| 1. MP: Standard body
MPS: Short body | 4. Color of LED
R: Red
Y: Yellow
G: Green
B: Blue
C: Clear/White
Top to bottom | 5. Color of lense
Blank: Colored lens
B0738: Clear lens |
|---|--|---|

Ordering information

Number of stacks	Rated voltage	Power consumption	Open collector	Order code
1	24 VAC/VDC	0.7 W	NPN/PNP	MP/MPS-102
2		1.4 W		MP/MPS-202
3		2.0 W		MP/MPS-302
4		2.6 W		MP/MPS-402
5		3.2 W		MP/MPS-502

Features

Patented reflection system increases visibility.

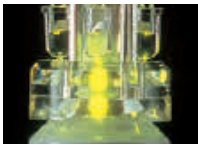

High intensity LED



Good visibility from any direction

Interchangeable LED modules

- Changeable color sequence: Easy to add/remove up to 5 colored modules even after installation.
- Note: LED modules of the same color will light up simultaneously.

The wiring remains the same.

Each color of LED module corresponds to the lead wire color.



Dimensions

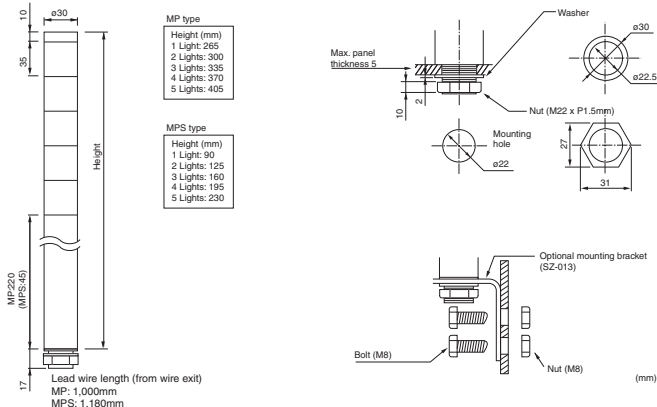

Wiring diagram

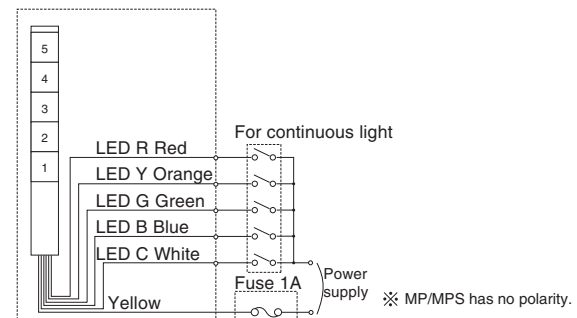

Specifications

Size	30 mm diameter
Input voltage options	24 VAC/VDC
Functions available	Continuous only
Mounting options	Direct mount only; includes M22 mounting nut and sealing gasket
Body style	<ul style="list-style-type: none"> • pre-assembled, pre-wired • Interchangeable and stackable after purchase
Body color	Silver
Tiers	1-5 modules can be stacked
Module colors	Red / Yellow / Green / Blue / Clear-White (for sunlight applications: clear-lense modules in all colors available)
Alarms (FB style only)	<ul style="list-style-type: none"> • CE • UL component recognition (US) • UL component recognition (Canada) • RoHS
Protection	IP-65
Control options	<ul style="list-style-type: none"> • Dry contact closure such as switches or relay contacts • Open-collector transistor (NPN or PNP) for 24 VDC • Direct voltage control

PATLITE distributed by Omron



Versatile, cost and energy efficient LED signal tower for every need

The LME series indicating light provides the latest in LED technology. 1 to 5 modules can be arranged in tiers. The original dual reflection system for enhanced light diffusion, creates bright distinctive illumination while saving energy (patent pending).

LME signal towers provide double insulation and superior UV resistant and light translucent AS resin lenses for enhanced durability and reliability in application environment.

Available Colors are Red, Yellow, Green, Blue and Clear/White.
All colors as clear-lense modules are available

- Diameter: 60 mm
- 2 selectable built-in alarms with adjustable volume up to 90 dB at 1 m for FB type
- Special pre-wired versatile and flexible cable connection of 3 m
- NPN/ PNP compatible
- IP 65

Ordering information

LME-502UFBW-C-RYGBC-Z
1 2 3 4 5 6 7 8

- | | | |
|--|--|---|
| <p>1. Stack
1 ~ 5</p> <p>2. Rated voltage
02: 24V AC/DC</p> <p>3. Body color
Blank: Ivory white
N: Black color
U: Silver color</p> | <p>4. Type
Blank: Continuous light
FB: Continuous light or flashing light with audible alarm</p> <p>5. Mount
Blank: Pole mount
K: Pole mount (with SZ-020)
W: Direct mount</p> <p>6. Connection
C: pre-wired cable 3 m</p> | <p>7. Color of LED
R: Red
Y: Yellow
G: Green
B: Blue
C: Clear/White</p> <p>8. Color of Lens
Blank: Colored lens
Z: Clear lens</p> |
|--|--|---|

Ordering information

Number of stacks	Mount	Model	Rated voltage	Power consumption	Open collector	Order code	
						Continuous light	Continuous light with audible alarm
1	Pole mount	LME-102	24 VAC/DC	2.2 W	NPN/PNP	LME-102-C	LME-102-FB-C
	Direct mount		24 VAC/DC			LME-102W-C	LME-102-FBW-C
2	Pole mount	LME-202	24 VAC/DC	3.4 W		LME-202-C	LME-202-FB-C
	Direct mount		24 VAC/DC			LME-202W-C	LME-202-FBW-C
3	Pole mount	LME-302	24 VAC/DC	3.8 W		LME-302-C	LME-302-FB-C
	Direct mount		24 VAC/DC			LME-302W-C	LME-302-FBW-C
4	Pole mount	LME-402	24 VAC/DC	4.2 W		LME-402-C	LME-402-FB-C
	Direct mount		24 VAC/DC			LME-402W-C	LME-402-FBW-C
5	Pole mount	LME-502	24 VAC/DC	4.6 W		LME-502-C	LME-502-FB-C
	Direct mount		24 VAC/DC			LME-502W-C	LME-502-FBW-C

Optional parts

Typ	Material	Order code
Wall mount bracket	Aluminum alloy die-cast	SZ-017
	ABS resin	SZ-020
	PBT/ ABS resin	SZ-028
Mount bracket	Aluminum alloy die-cast	SZ-016A
	Aluminum alloy die-cast	SZ-010

Typ	Height	Material	Order code
Pole	100 mm	Aluminium	Pole-100A21
		Steel	Pole-100S21
	300 mm	Aluminium	Pole-300A21
		Steel	Pole-300S21
	800 mm	Aluminium	Pole-800A21
		Steel	Pole-800S21

Dimensions

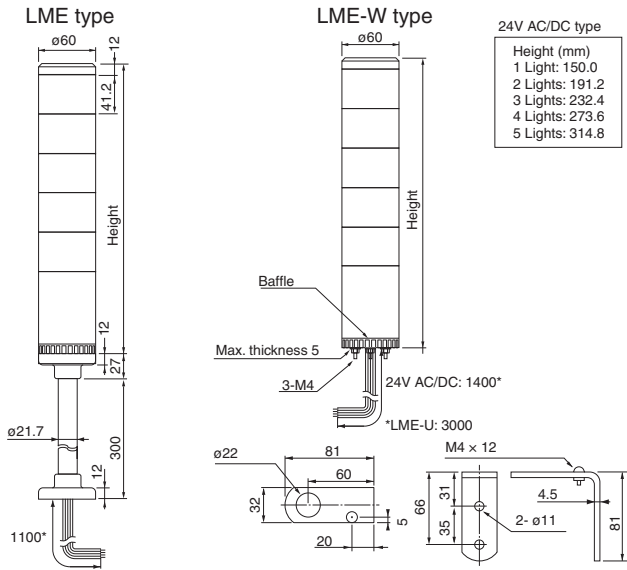

Wiring diagram

LME(-W)/LME(-W)-S-Q/LMS [Continuous type]

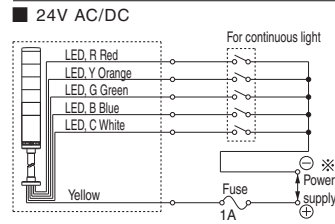

Features

Interchangeable LED modules

- Changeable color sequence: Easy to add / remove up to 5 colored modules even after installation.
- Note: LED modules of the same color within a signal tower will light up simultaneously.

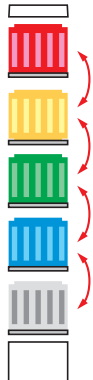

Easy to add and remove

If the number of LED module is changed, center shaft must be purchased.

The wiring remains the same

Each color of LED module corresponds to the lead wire color.

Dual reflection system

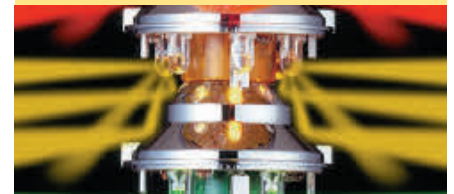

PATLITE's original dual reflection system with its exclusive hybrid prism-cut lens and 5 color LED modules create bright, distinctive, even illumination.



To bring more attention to certain conditions, two, User-selectable, Alarms integrated in the Base module with adjustable volume up to 85 dB at 1m are available.

Specifications

Size	60 mm diameter
Input voltage options	• 24 VAC/VDC
Functions available	• Continuous only • Continuous, flashing, alarms
Mounting options	• Pole mount: with 300 mm aluminum pole, plastic circular bracket • Direct mount: includes 3 mounting nuts
Body style	• Pre-assembled, pre-wired • Interchangeable and stackable after purchase
Body color	Beige (optional: Black or silver)
Tiers	1-5 modules can be stacked
Module colors	Red / Yellow / Green / Blue / Clear/White (for sunlight applications: clear-lense modules in all colors available)
Alarms (FB style only)	• Alarm 1: selectable, single-tone, intermittent (fast beep) alarm, 85 dB (at 1 m) • Alarm 2: selectable, single tone, intermittent (slow beep) alarm, 85 dB (at 1 m)
Ratings	• CE • UL component recognition (US) • UL component recognition (Canada) • RoHS
Protection	• IP-65 (LME, LME-W) • IP-54 (LME-FB, LME-FBW) • Type 4/4X/13 (indoor, direct-mount only)
Control options	• Dry contact closure such as switches or relay contacts • Open-collector transistor (NPN or PNP for 24 VDC) • Direct voltage control for 24 VDC, continuous and alarm functions only

PRECISE MONITORING OF GUARD POSITION

Detect linear or rotational movement of guards: D4N

Guards and covers on machines protect workers. They limit access to the dangerous parts of the machine. Our safety limit switches guarantee that the guards and covers are in place before the machine is started.

- Wide variety of actuators to fit wide range of applications
- Gold-plated contacts for reliable operation with micro loads

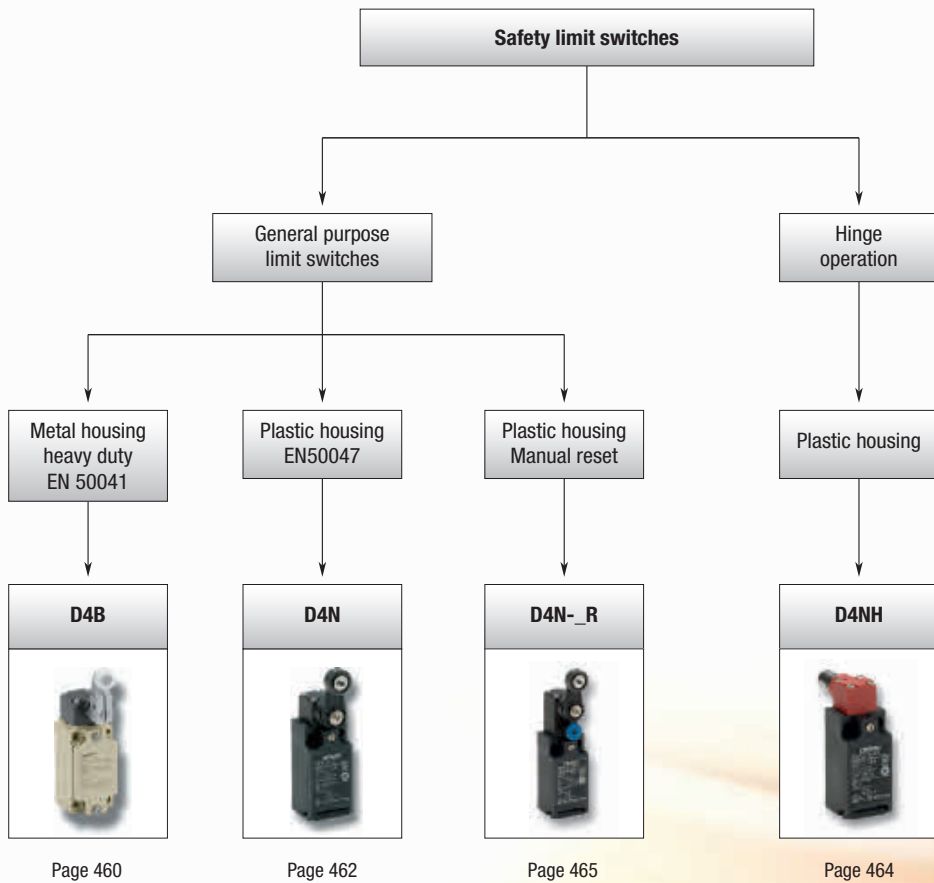

Page 460

Page 462

Page 465

Page 464

		Safety limit switches			
					
Selection criteria	Model	D4B	D4N	D4NH	D4N- <u>R</u>
	Housing	Metal	Plastic	Plastic	Plastic
	M12 Plug connector	–	■	■	–
	Protection class	IP67			
	Operating Temperature Range	-40 to 80°C	-30 to 70°C	-30 to 70°C	-30 to 70°C
Conformity	EN50047, EN1088				
Features	Conduit size M20	■	■	■	■
	Gold clad contacts	■	■	■	■
	Actuators				
	Resin roller, resin lever	–	■	–	■
	Resin roller, metal lever	■	■	–	–
	Metal roller, metal lever	–	■	–	–
	Bearing lever, metal lever	–	■	–	–
	Adj. resin roller, metal lever	■	■	–	■
	Adj. Rubber roller, metal lever	–	■	–	■
	Adj. Rod lever	■	–	–	–
	Top plunger	■	■	–	■
	Top roller plunger	■	■	–	■
	Horizontal roller arm lever	–	■	–	■
	Vertical roller arm lever	–	■	–	■
	Cat whisker	–	■	–	–
	Plastic Rod	■	■	–	–
	Fork lever lock (right operation)	–	■	–	–
Fork lever lock (left operation)	–	■	–	–	
Hinge operation	■	–	■	–	
Application	Position monitoring	■	■	■	■
Contact configuration	1NC/1NO snap action	■	■	–	–
	2NC snap action	–	■	–	–
	1NC/1NO slow action	■	■	■	■
	2NC slow action	■	■	■	■
	2NC/1NO slow action	–	■	■	■
	3NC slow action	–	■	■	■
	1NC/1NO (MBB slow action)	–	■	■	–
	2NC/1NO (MBB slow action)	–	■	■	–
Page	460	462	464	465	

■ Standard

– No/not available



Limit switch with metal housing

The D4B series of limit switches in a rugged metal housing is suitable for both safety and non-safety applications due to its direct opening mechanism and TÜV approval. Furthermore with the increased temperature range and enhanced mechanical switching lifetime, the D4B is first choice for all applications from standard to demanding environments and for highest flexibility in mounting and connectivity preferences.

- Direct opening mechanism and approval by notified body
- Rugged metal housing and extended mechanical switching lifetime (snap action models)
- Terminal block for direct wiring

Ordering information

Actuator type		Connection method	Order code*1		
			1NC/1NO (snap-action)	1NC/1NO (slow-action)	2NC (slow-action)
	Roller lever*2	Terminal block with M20 conduit	D4B-4111N	D4B-4511N	D4B-4A11N
	Adjustable roller lever		D4B-4116N	D4B-4516N	D4B-4A16N
	Adjustable rod lever		D4B-4117N	D4B-4517N	D4B-4A17N
	Plain		D4B-4170N	D4B-4570N	D4B-4A70N
	Roller		D4B-4171N	D4B-4571N	D4B-4A71N
	Coil spring		D4B-4181N*3	–	–
	Plastic rod		D4B-4187N*3	–	–

*1 The NC contacts provide the approved direct opening mechanism.

*2 For models with stainless steel rollers and temperature resistance of -40°C refer to WL-_-TC.

*3 No direct opening mechanism

Specifications

Item		Snap-action	Slow-action
Durability*1	Mechanical	30,000,000 operations min.	10,000,000 operations min.
	Electrical	500,000 operations min. (at a 250 VAC, 10 A resistive load)	
Operating speed		1 mm/s to 0.5 m/s	
Operating frequency	Mechanical	120 operations/min	
	Electrical	30 operations/min	
Rated frequency		50/60 Hz	
Contact resistance		25 mΩ max. (initial value)	
Pollution degree (operating environment)		3 (EN60947-5-1)	
Conditional short-circuit current		100 A (EN60947-5-1)	
Conventional enclosed thermal current (I _{th})		20 A (EN60947-5-1)	
Protection against electric shock		Class I (with ground terminal)	
Ambient temperature	Operating	-40 to 80°C (with no icing)*2	
Degree of protection		IP67 (EN60947-5-1)	

*1 The values are acquired for an ambient temperature of 5 to 35°C and an ambient humidity of 40 to 70%.

*2 -25 to 80°C for the flexible-rod actuator.

1NO/1NC Contact (Snap-action)

If metal deposition between mating contacts occurs on the NC contact side, they can be pulled apart by the shearing force and tensile force generated when part B of the

safety cam or plunger engages part A of the movable contact blade. When the safety cam or plunger is moved in the direction of the arrow, the Limit Switch releases.

1. When metal deposition occurs.

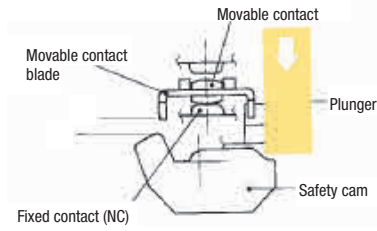

2. When contacts are being pulled apart.

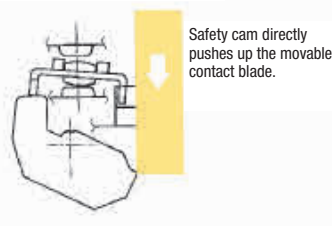

3. When contacts are completely pulled apart.

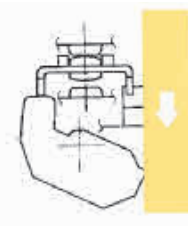

1NC/1NO Contact (Slow-action)

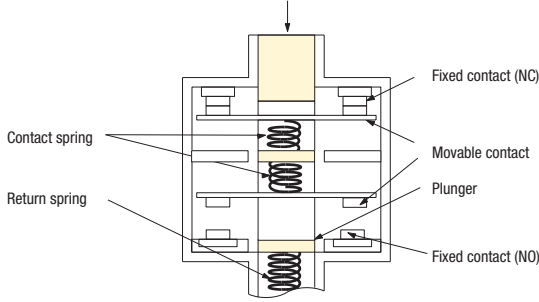

2NC Contact (Slow-action)

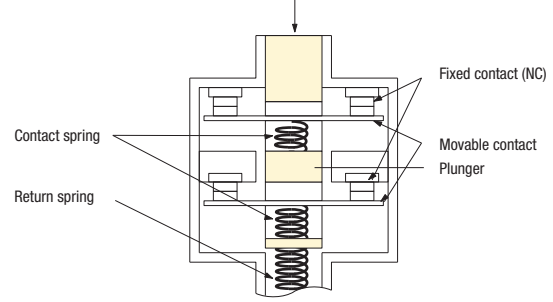

NC contacts conform to EN60947-5-1 Direct Opening

When metal deposition occurs, the contacts are separated from each other by the plunger being pushed in.

⊖ is marked on the product to indicate approval of direct opening.









Limit switch with plastic housing

The D4N series of limit switches in plastic housing is the ideal switch for all standard mechanical position detection applications both for safety and non-safety applications.



- Direct opening mechanism and approval by notified body
- Rugged plastic housing with double insulation
- Wide range of actuators
- M12 connectors or terminal block with M20 conduit

Ordering information

Actuator type		Connection method	Order code* ¹			
			1NC/1NO (snap-action) Order code	1NC/1NO (slow-action) Order code	2NC (slow-action) Order code	2NC/1NO (slow-action) Order code
 Roller lever (resin lever, resin roller)	M20	D4N-4120	D4N-4A20	D4N-4B20	D4N-4C20	
	M12 connector	D4N-9120	D4N-9A20	D4N-9B20	–	
 Plunger	M20	D4N-4131	D4N-4A31	D4N-4B31	–	
	M12 connector	D4N-9131	D4N-9A31	D4N-9B31	–	
 Roller plunger	M20	D4N-4132	D4N-4A32	D4N-4B32	D4N-4C32	
	M12 connector	D4N-9132	D4N-9A32	D4N-9B32	–	
 One-way roller arm lever (horizontal)	M20	D4N-4162	D4N-4A62	D4N-4B62	D4N-4C62	
	M12 connector	D4N-9162	D4N-9A62	D4N-9B62	–	
 One-way roller arm lever (vertical)	M20	D4N-4172	D4N-4A72	D4N-4B72	–	
 Adjustable roller lever, form lock (metal lever, resin roller)	M20	D4N-412G	D4N-4A2G	D4N-4B2G	–	
	M12 connector	D4N-912G	D4N-9A2G	D4N-9B2G	–	
 Adjustable roller lever, form lock (metal lever, rubber roller)	M20	D4N-412H	D4N-4A2H	D4N-4B2H	–	
	M12 connector	D4N-912H	D4N-9A2H	D4N-9B2H	–	

Switches with MBB contacts

MBB (Make Before Break) contacts have an overlapping structure, so that before the normally closed (NC) contact opens the normally open (NO) contact closes.

Actuator type		Connection method	Order code* ¹	
			1NC/1NO (slow-action)	2NC/1NO (slow-action)
 Roller lever (resin lever, resin roller)	M20	D4N-4E20	D4N-4F20	
	M12 connector	D4N-9E20	–	
 Roller plunger	M20	D4N-4E32	D4N-4F32	
	M12 connector	D4N-9E32	–	
 One-way roller arm lever (horizontal)	M20	D4N-4E62	D4N-4F62	
	M12 connector	D4N-9E62	–	

*¹ The NC contacts provide the approved direct opening mechanism. 

Specifications

Durability ^{*1}	Mechanical	15,000,000 operations min. ^{*2}
	Electrical	500,000 operations min. for a resistive load of 3 A at 250 VAC 300,000 operations min. for a resistive load of 10 A at 250 VAC
Operating speed	Roller lever	1 mm/s to 0.5 m/s
Operating frequency		30 operations/minute max.
Minimum applicable load		Resistive load of 1 mA at 5 VDC (N-level reference value)
Protection against electric shock		Class II (double insulation)
Pollution degree (operating environment)		3 (EN60947-5-1)
Contact gap		Snap-action: 2x0.5 mm min Slow-action: 2x2 mm min
Conditional short-circuit current		100 A (EN60947-5-1)
Rated open thermal current (I_{th})		10 A (EN60947-5-1)
Ambient temperature	Operating	-30°C to 70°C with no icing
Degree of protection		IP67 (EN60947-5-1)

^{*1} The durability is acquired for an ambient temperature of 5°C to 35°C and an ambient humidity of 40 to 70%.

^{*2} 10,000,000 operations min. for fork lever actuator.

1NO/1NC Contact (Snap-action)

If metal deposition between mating contacts occurs on the NC contact side, they can be pulled apart by the shearing force and tensile force generated when part B of the

safety cam or plunger engages part A of the movable contact blade. When the safety cam or plunger is moved in the direction of the arrow, the Limit Switch releases.

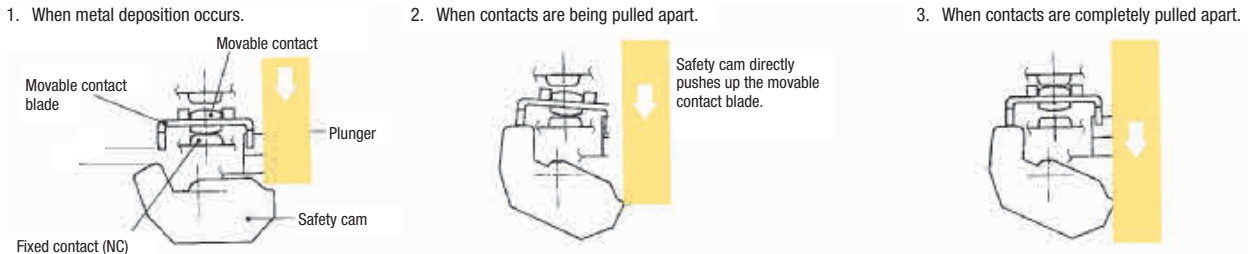

1NC/1NO Contact (Slow-action)

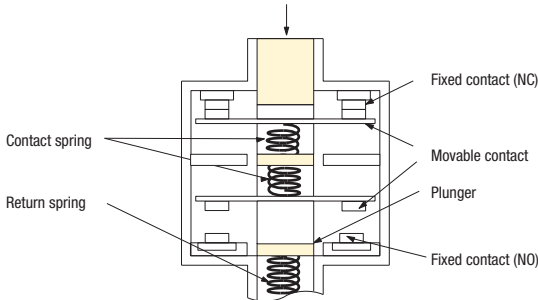

2NC Contact (Slow-action)

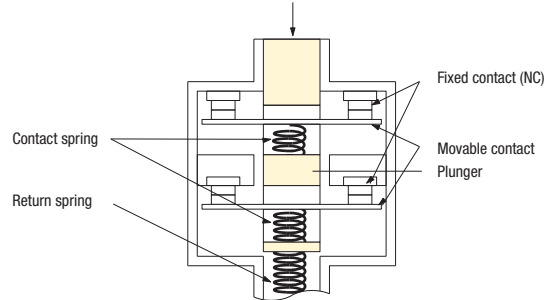

NC contacts conform to EN60947-5-1 Direct Opening

When metal deposition occurs, the contacts are separated from each other by the plunger being pushed in.

⊕ is marked on the product to indicate approval of direct opening.



Safety door hinge switch

D4NH safety-door hinge switches are available with one or two built-in contacts, shaft or arm lever actuator and various conduit types, e.g. M20.

- Direct opening mechanism
- Shaft or arm lever actuator
- Wide temperature range
- Metric conduit and M12 connector types are available

Ordering information

Switches

Actuator	Conduit size		Built-in switch mechanism		
			1NC/1NO (slow-action)	2NC (slow-action)	2NC/1NO (slow-action)
Shaft	1-conduit	M20	D4NH-4AAS	D4NH-4BAS	D4NH-4CAS
		M12 connector	D4NH-9AAS	D4NH-9BAS	–
Arm lever	1-conduit	M20	D4NH-4ABC	D4NH-4BBC	D4NH-4CBC
		M12 connector	D4NH-9ABC	D4NH-9BBC	–

Actuator	Conduit size		Built-in switch mechanism		
			3NC (slow-action)	1NC/1NO MBB (slow-action)	2NC/1NO MBB (slow-action)
Shaft	1-conduit	M20	D4NH-4DAS	D4NH-4EAS	D4NH-4FAS
		M12 connector	–	D4NH-9EAS	–
Arm lever	1-conduit	M20	D4NH-4DBC	D4NH-4EBC	D4NH-4FBC
		M12 connector	–	D4NH-9EBC	–

Specifications

Degree of protection		IP67 (EN60947-5-1)
Durability	Mechanical	1,000,000 operations min.
	Electrical	500,000 operations min. for a resistive load of 3 A at 250 VAC 300,000 operations min. for a resistive load of 10 A at 250 VAC
Operating speed		2 to 360°/s
Operating frequency		30 operations/minute max.
Protection against electric shock		Class II (double insulation)
Pollution degree (operating environment)		3 (EN60947-5-1)
Contact gap		Snap-action: 2x9.5 mm min Slow-action: 2x2 mm min
Conditional short-circuit current		100 A (EN60947-5-1)
Rated open thermal current (I _{th})		10 A (EN60947-5-1)
Ambient temperature		Operating: -30°C to 70°C with no icing



Safety-limit switch with manual reset

The D4NR family is a complete line-up of safety-limit switches with manual reset. They are available with one, two or three built-in contacts and a wide range of actuator types. To set up easy installation and maintenance, various conduit types, e.g. M20 and M12 connector types, are provided.

- Direct opening mechanism
- Various actuators
- Pull-reset switches
- Gold-plated contacts for handling micro loads
- Metric conduit types available

Ordering information

Switches		Conduit size		Order code	
				Built-in switch mechanism	
				1NC/1NO (slow-action)	2NC/1NO (slow-action)
	Roller lever (resin lever, resin roller)	1-conduit	M20	D4N-4A20R	D4N-4C20R
			M12 connector	D4N-9A20R	–
	Adjustable roller lever, form lock (metal lever, rubber roller)	1-conduit	M20	D4N-4A2HR	D4N-4C2HR
			M12 connector	D4N-9A2HR	–
	Plunger	1-conduit	M20	D4N-4A31R	D4N-4C31R
			M12 connector	D4N-9A31R	–
	Roller plunger	1-conduit	M20	D4N-4A32R	D4N-4C32R
			M12 connector	D4N-9A32R	–

Specifications

Degree of protection		IP67 (EN60947-5-1)
Durability	Mechanical	1,000,000 operations min.
	Electrical	500,000 operations min. for a resistive load of 3 A at 250 VAC 300,000 operations min. for a resistive load of 10 A at 250 VAC
Operating speed		1 mm/s to 0.5 m/s (D4N-1A20R)
Operating frequency		30 operations/minute max.
Protection against electric shock		Class II (double insulation)
Pollution degree (operating environment)		3 (EN60947-5-1)
Contact gap		Snap-action: 2×0.5 mm min Slow-action: 2×2 mm min
Rated open thermal current (I_{th})		10 A (EN60947-5-1)
Ambient temperature		Operating: -30°C to 70°C with no icing

BREAK CONVENTIONAL BARRIERS IN SAFETY DESIGN

Flexibility selecting best fit control device for non-contact switch application: F3S-TGR-N

Omron has introduced a series of magnetic coded contactless switches for interlocking machine guard doors. The switches feature a built-in control function, thus saving the cost and space required for an external controller. The non-contact switches offer advantages in applications where a precise approach of the guard and lock is not possible. Applications with a large amount of dirt or high hygienic standards can also be addressed.

- Operates with all Omron safety relay units and safety bus interfaces
- Operates behind stainless steel fittings
- Non-contact – no abrasion – no particles
- Conforms to safety categories up to 4 acc. EN 954-1 and PLe acc. EN ISO 13849-1

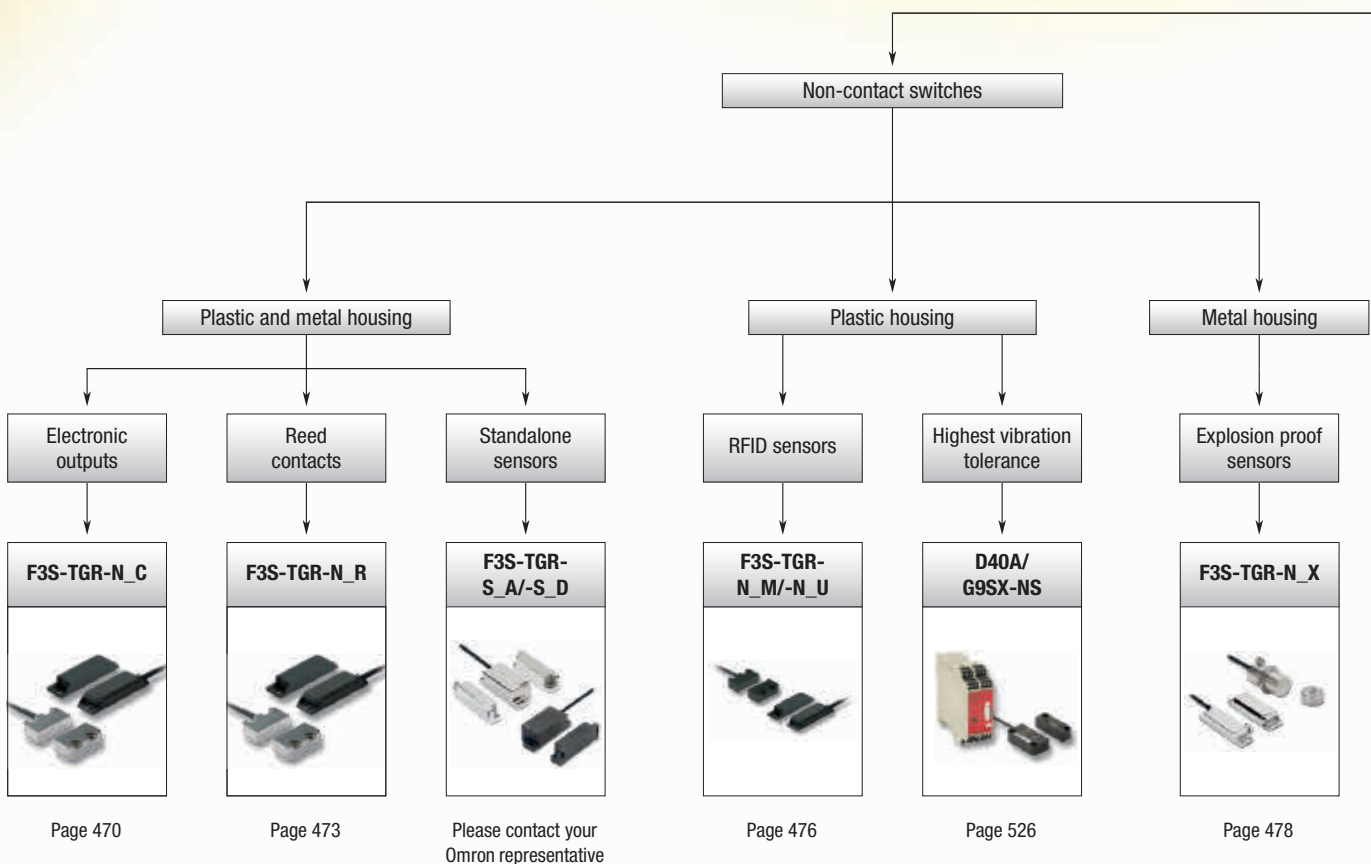

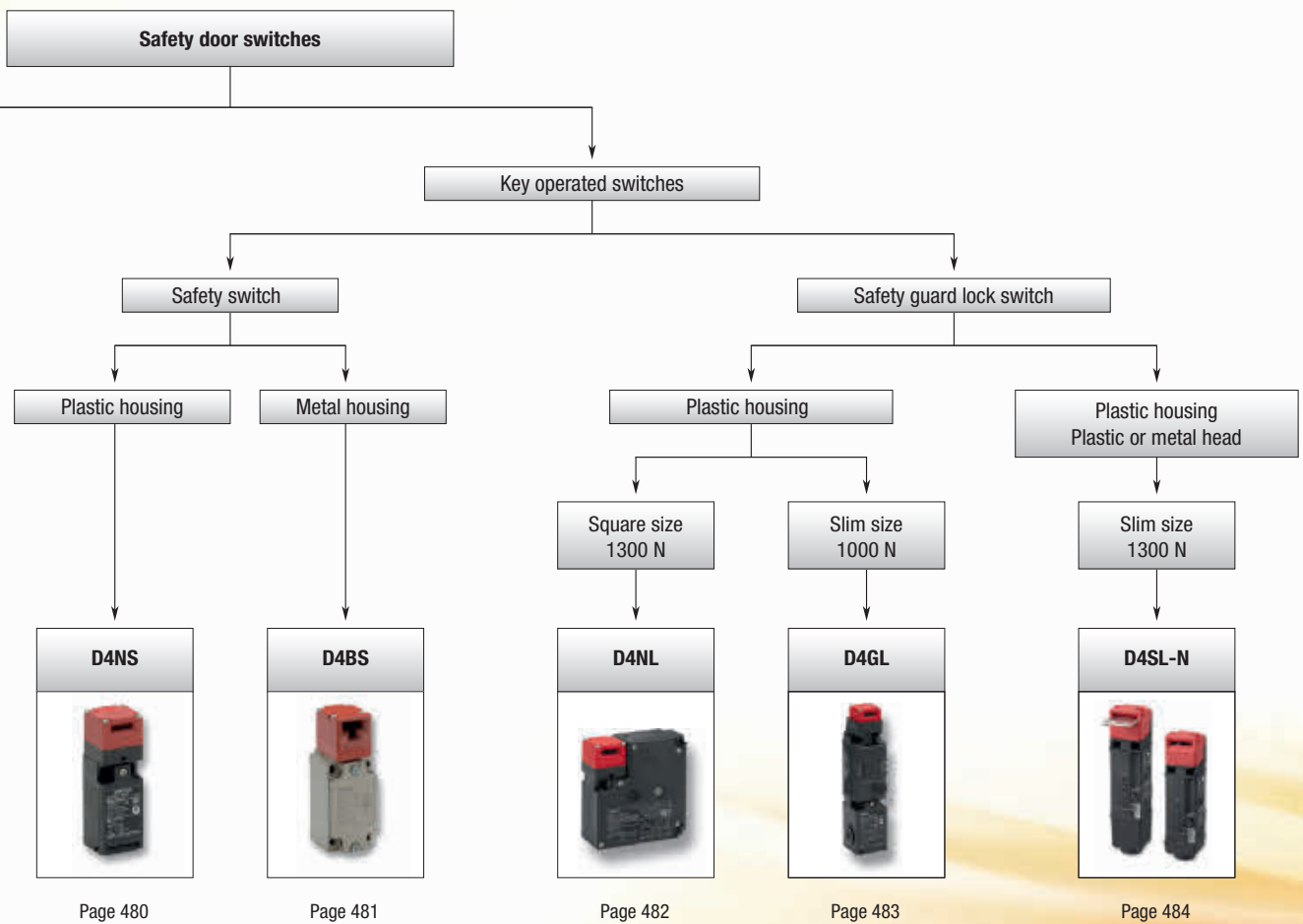

Selection table

		Non-contact safety door switches					
							
Selection criteria	Model	F3S-TGR-N_C	F3S-TGR-N_R	F3S-TGR-N_M/-N_U	F3S-TGR-S_A/-S_D	F3S-TGR-N_X	D40A/G9SX-NS
	Housing	Plastic/Metal	Plastic/Metal	Plastic	Plastic/Metal	Metal	Plastic
	Protection class	IP67/IP69K	IP67/IP69K	IP67/IP69K	IP67/IP69K	IP67	IP67
	Conformity	EN ISO 13849-1, EN60947-5-3	EN ISO 13849-1, EN60947-5-3	EN ISO 13849-1, EN60947-5-3	EN ISO 13849-1, EN60947-5-3	EN ISO 13849-1, EN60947-5-3	EN ISO 13849-1
Features	Cable length 2 m	■	■	–	–	–	■
	Cable length 5 m	■	■	■	■	■	■
	Cable length 10 m	■	■	■	■	■	–
	Connector type M12	■	■	■	■	■	–
	High temperature sensor	■	■	–	–	–	–
	Operates with G9SA, G9SB	■	■	■	■	■	–
	Operates with G9SX	■	■	■	■	■	■
	Operates with programmable safety units G9SP and NE1A	■	■	■	■	■	–
Application	Door monitoring	■	■	■	■	■	■
Contact configuration	1NC/1NO	–	–	–	–	–	■
	2NC	■	■	–	–	–	–
	2NC/1NO	■	■	■	■	■	–
	Force guided relays	–	–	–	■	–	–
	Page	470	473	476	Please contact your Omron representative	478	526

		Safety door switches		Safety door lock switches			
							
		D4NS	D4BS	D4NL	D4GL	D4SL-N	
Selection criteria	Model	D4NS	D4BS	D4NL	D4GL	D4SL-N	
	Housing	Plastic	Metal	Plastic	Plastic	Plastic/metal head available	
	Head mounting	4 directions	4 directions	4 directions	4 directions	4 directions	
	Actuation	Straight	Straight	Straight	Straight	Straight	
	Key holding force	–	–	1,300 N	1,000 N	1,300 N	
	Protection class	IP67	IP67	IP67	IP67	IP67	
Conformity		EN50047, EN1088	EN50047, EN1088	EN1088	EN1088	EN1088	
Features	Conduit size M20	■	PG 13.5	■	■	■	
	Screw terminal	■	■	■	■	■	
	Connector terminal	–	–	–	–	■	
	Operation key horizontal	■	■	■	■	■	
	Operation key vertical	■	■	■	■	■	
	Operation key adjustable horizontal	■	■	■	■	■	
	Operation key adjustable horizontal and vertical	■	–	■	■	■	
	Mechanical lock/ 24 VDC solenoid release	–	–	■	■	■	
	Mechanical lock/ 110 VAC solenoid release	–	–	■	–	–	
	Mechanical lock/ 230 VAC solenoid release	–	–	■	–	–	
	24 VDC solenoid lock/ mechanical release	–	–	■	■	■	
	110 VAC solenoid lock mechanical release	–	–	■	–	–	
	240 VAC solenoid lock mechanical release	–	–	■	–	–	
	High temperature sensor	–	–	–	–	–	
	Operates with G9SR	■	■	■	■	■	
	Operates with G9SA, G9SB	■	■	■	■	■	
	Operates with G9SX	■	■	■	■	■	
	Operates with programmable safety units G9SP and NE1A	■	■	■	■	■	
	Application	Door monitoring	■	■	■	■	■
		Door locking	–	–	■	■	■
Contact configuration	2 contact models	■	■	–	–	–	
	3 contact models	■	–	–	–	–	
	4 contact models	–	–	■	■	■	
	5 contact models	–	–	■	■	■	
	6 contact models	–	–	–	–	■	
	Slow action contacts	■	–	–	–	–	
Page		480	481	482	483	484	

■ Standard

– No/not available







Non-contact switches for monitoring the status of guarding doors

Non-contact switches monitor the status of guarding doors. LED for easy diagnosis and stainless steel housing for high hygiene demands in the food industry are available

- Connect up to 3 switches in series
- Operates with all Omron safety controllers
- Operates behind stainless steel fittings
- Non-contact – no abrasion – no particles
- Screw-hole covers support hygienic design (NMPC)
- Conforms to safety categories up to PLe acc. EN ISO13849-1



Ordering information

Polyester housing



Type	Cable connection	Contact configuration	Order code
 Elongated sensors	5 m pre-wired	2NC/1NO	F3S-TGR-NLPC-21-05
	10 m pre-wired		F3S-TGR-NLPC-21-10
	M12, 8-pin		F3S-TGR-NLPC-21-M1J8
 Small sensors	5 m pre-wired		F3S-TGR-NSPC-21-05
	10 m pre-wired		F3S-TGR-NSPC-21-10
	M12, 8-pin		F3S-TGR-NSPC-21-M1J8
 Miniature sensors	5 m pre-wired*		F3S-TGR-NMPC-21-05
	10 m pre-wired*		F3S-TGR-NMPC-21-10
	M12, 8-pin*		F3S-TGR-NMPC-21-M1J8
 Barrel sensors	5 m pre-wired		F3S-TGR-NBPC-21-05
	10 m pre-wired		F3S-TGR-NBPC-21-10
	M12, 8-pin		F3S-TGR-NBPC-21-M1J8

* Optional cable exit to the right side is available for F3S-TGR-NMPC-types. Please add "-R" to the order code (i.e. F3S-TGR-NMPC-21-05-R)

Stainless steel housing

Type	Cable connection	Contact configuration	Order code
 Elongated sensors	5 m pre-wired	2NC/1NO	F3S-TGR-NLMC-21-05
	10 m pre-wired		F3S-TGR-NLMC-21-10
	M12, 8-pin		F3S-TGR-NLMC-21-M1J8
 Small sensors	5 m pre-wired		F3S-TGR-NSMC-21-05
	10 m pre-wired		F3S-TGR-NSMC-21-10
	M12, 8-pin		F3S-TGR-NSMC-21-M1J8
 Barrel sensors	5 m pre-wired		F3S-TGR-NBMC-21-05
	10 m pre-wired		F3S-TGR-NBMC-21-10
	M12, 8-pin		F3S-TGR-NBMC-21-M1J8

Hygienic and food types

Type	Cable connection	Contact configuration	Order code
 Small sensors	5 m pre-wired	2NC/1NO	F3S-TGR-NSHC-21-05
	10 m pre-wired		F3S-TGR-NSHC-21-10
	M12, 8-pin		F3S-TGR-NSHC-21-M1J8
 Small sensors (Special food type)	5 m pre-wired		F3S-TGR-NSFC-21-05
	10 m pre-wired		F3S-TGR-NSFC-21-10
	M12, 8-pin		F3S-TGR-NSFC-21-M1J8
 Miniature sensors	5 m pre-wired*		F3S-TGR-NMHC-21-05
	10 m pre-wired*		F3S-TGR-NMHC-21-10
	M12, 8-pin*		F3S-TGR-NMHC-21-M1J8

* Optional cable exit to the right side is available for F3S-TGR-NMHC-types. Please add "-R" to the order code (i.e. F3S-TGR-NMHC-21-05-R)

Specifications

Mechanical data

Item	Model	Polyester types	Stainless steel types
Operating distance*	OFF → ON (Sao)	Min. 8 mm/max. 10 mm	
	ON → OFF (Sar)	Min. 12 mm/max. 22 mm	
Actuator approach speed	Min.	4 mm/s	
	Max.	1,000 mm/s	
Operating temperature	–	–25 to 80°C	–25 to 105°C
Enclosure protection	Flying lead M12 connector	IP69K IP67	
Material	–	Black polyester	Stainless steel 316

* Depends on type. Please see online data sheet.

Electrical data

Item	Model	Polyester types	Stainless steel types
Power supply	–	24 VDC±15%	
Power consumption	Max.	50 mA	
Switching current	Min.	10 mA, 10 VDC	
Rated loads	NC contacts	Max.	100 mA, 24 VDC 100 mA, 24 VDC
	NO contact		
Output type	–	Electronic output (potential-free optocoupler output)	

Approved standards

EN standards certified by TÜV Rheinland
EN 954-1, EN ISO13849-1
EN 60204-1
EN/IEC 60947-5-3
UL 508, CSA C22.2
BS 5304
EN 1088-1 conformance

Wiring examples (Single head connection)

G9SA

Single sensor application with G9SA-301
(up to PLe acc. EN ISO 13849-1)

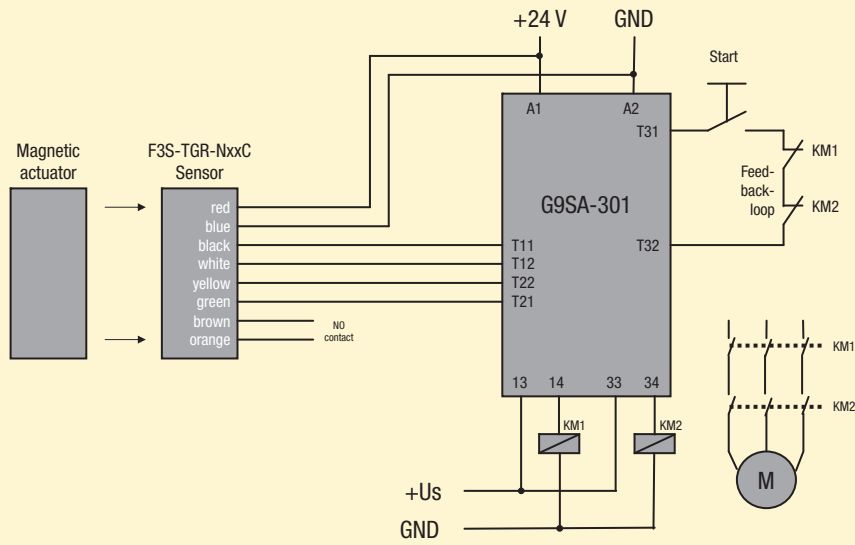







Non-contact switches for monitoring the status of guarding doors

Non-contact switches monitor the status of guarding doors. Stainless steel housing for high hygiene demands in the food industry are available.

- Connect up to 6 switches in series
- Operates with all Omron safety controllers
- Operates behind stainless steel fittings
- Non-contact – no abrasion – no particles
- Screw-hole covers support hygienic design (NMPPR)
- Conforms to safety categories up PLe acc. EN ISO13849-1

Ordering information

Polyester housing



Type	Cable connection	Contact configuration	Order code	
Elongated sensors 	5 m pre-wired	2NC/1NO ^{*1}	F3S-TGR-NLPR-21-05	
	10 m pre-wired		F3S-TGR-NLPR-21-10	
	M12, 8-pin		F3S-TGR-NLPR-21-M1J8	
Small sensors 	5 m pre-wired		F3S-TGR-NSPR-21-05	
	10 m pre-wired		F3S-TGR-NSPR-21-10	
	M12, 8-pin		F3S-TGR-NSPR-21-M1J8	
Miniature sensors 	5 m pre-wired ^{*2}		2NC/1NO ^{*3}	F3S-TGR-NMPPR-21-05
	10 m pre-wired ^{*2}			F3S-TGR-NMPPR-21-10
	M12, 8-pin ^{*2}			F3S-TGR-NMPPR-21-M1J8
Barrel sensors 	5 m pre-wired	F3S-TGR-NBPR-21-05		
	10 m pre-wired	F3S-TGR-NBPR-21-10		
	M12, 8-pin	F3S-TGR-NBPR-21-M1J8		

^{*1} 2NC: 1 A, 250 VAC/1NC: 0.2 A, 24 VDC

^{*2} Optional cable exit to the right side is available for F3S-TGR-NMHR-types. Please add "-R" to the order code (i.e. F3S-TGR-NMPPR-21-05-R)

^{*3} 2NC: 0.5 A, 24 VDC/1NC: 0.2 A, 24 VDC



Stainless steel housing

Type	Cable connection	Contact configuration	Order code	
Elongated sensors 	5 m pre-wired	2NC/1NO ^{*1}	F3S-TGR-NLMR-21-05	
	10 m pre-wired		F3S-TGR-NLMR-21-10	
	M12, 8-pin		F3S-TGR-NLMR-21-M1J8	
Small sensors 	5 m pre-wired		F3S-TGR-NSMR-21-05	
	10 m pre-wired		F3S-TGR-NSMR-21-10	
	M12, 8-pin		F3S-TGR-NSMR-21-M1J8	
Barrel sensors 	5 m pre-wired		2NC/1NO ^{*2}	F3S-TGR-NBMR-21-05
	10 m pre-wired			F3S-TGR-NBMR-21-10
	M12, 8-pin			F3S-TGR-NBMR-21-M1J8

^{*1} 2NC: 1 A, 250 VAC/1NC: 0.2 A, 24 VDC

^{*2} 2NC: 0.5 A, 24 VDC/1NC: 0.2 A, 24 VDC

Hygienic and food types

Type	Cable connection	Contact configuration	Order code	
 Small sensors	5 m pre-wired	2NC/1NO ^{*1}	F3S-TGR-NSHR-21-05	
	10 m pre-wired		F3S-TGR-NSHR-21-10	
	M12, 8-pin		F3S-TGR-NSHR-21-M1J8	
 Small sensors (Special food type)	5 m pre-wired		F3S-TGR-NSFR-21-05	
	10 m pre-wired		F3S-TGR-NSFR-21-10	
	M12, 8-pin		F3S-TGR-NSFR-21-M1J8	
 Miniature sensors	5 m pre-wired ^{*2}		2NC/1NO ^{*3}	F3S-TGR-NMHR-21-05
	10 m pre-wired ^{*2}			F3S-TGR-NMHR-21-10
	M12, 8-pin ^{*2}			F3S-TGR-NMHR-21-M1J8

*1 2NC: 1 A, 250 VAC/1NC: 0.2 A, 24 VDC

*2 Optional cable exit to the right side is available for F3S-TGR-NMHR-types. Please add "-R" to the order code (i.e. F3S-TGR-NMHR-21-05-R)

*3 2NC: 0.5 A, 24 VDC/1NC: 0.2 A, 24 VDC

Specifications

Mechanical data

Item	Model	Plastic housing	Stainless steel housing
Operating distance	OFF → ON (Sao)	10 mm Close	
	ON → OFF (Sar)	20 mm* Open	
Actuator approach speed	Min.	4 mm/s	
	Max.	1,000 mm/s	
Operating temperature	–	–25 to 80°C	–25 to 105°C
Enclosure protection	Flying lead M12 connector	IP69K IP67	
Material	–	Black polyester	Stainless steel 316

* max. 22 mm, depends on the type

Electrical data

Item	Model	Plastic housing	Stainless steel housing
Contact release time	Max.	2 ms	
Initial contact resistance	Max.	500 mΩ	
Switching current	Min.	1 mA, 10 VDC	

Approved standards

EN standards certified by TÜV Rheinland
EN 954-1, EN ISO13849-1
EN 60204-1
EN/IEC 60947-5-3
UL 508, CSA C22.2
BS 5304
EN 1088-1 conformance

Wiring examples (Single head connection)

G9SA

Single sensor application with G9SA-301
(up to PLe acc. EN ISO 13849-1)

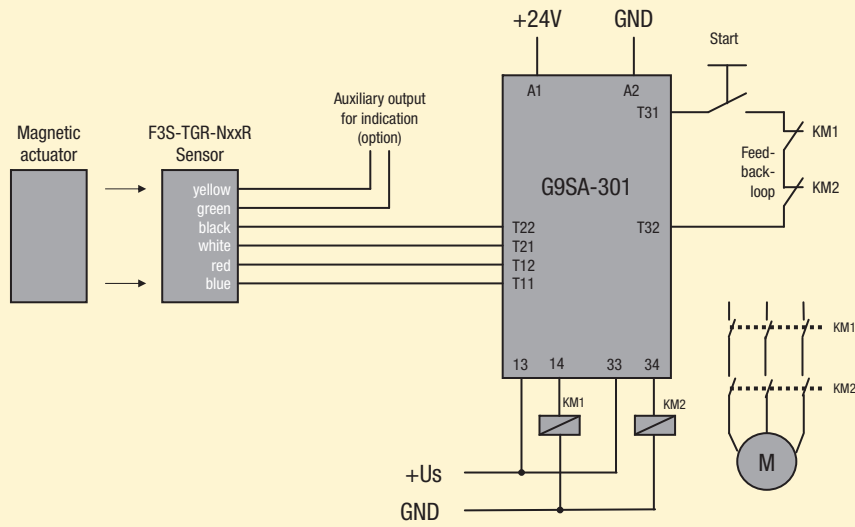



Tamper resistant non-contact switches

This line-up of non-contact switches uses a design based on RFID-technology.

The RFID-design covers two operation modes:

- 1) master coding: any switch works with any actuator – like traditional reed-switches.
 - 2) unique coding: each actuator and switch use a unique code.
This is a solution for applications that require high tamper resistance
- Connect up to 20 switches in series
 - LED for easy diagnosis
 - Suitable for high pressure cleaning, CIP and SIP processes due IP69K (pre-wired types)
 - Conforms to safety categories up to PLe acc. EN ISO 13849-1

Ordering information

Master coded: Any actuator will operate with any sensor
 Unique coded: Only one actuator fits to the code of the sensor

Elongated sensors

Type	Cable connection	Contact configuration	Order code	
			Master coded	Unique coded
	5 m pre-wired	2NC/1NO	F3S-TGR-NLPM-21-05	F3S-TGR-NLPU-21-05
	10 pre-wired		F3S-TGR-NLPM-21-10	F3S-TGR-NLPU-21-10
	M12, 8-pin		F3S-TGR-NLPM-21-M1J8	F3S-TGR-NLPU-21-M1J8

Small sensors

Type	Cable connection	Contact configuration	Order code	
			Master coded	Unique coded
	5 m pre-wired	2NC/1NO	F3S-TGR-NSPM-21-05	F3S-TGR-NSPU-21-05
	10 pre-wired		F3S-TGR-NSPM-21-10	F3S-TGR-NSPU-21-10
	M12, 8-pin		F3S-TGR-NSPM-21-M1J8	F3S-TGR-NSPU-21-M1J8

Specifications

Mechanical data

Item	Model	Elongated sensor	Small sensor
Operating distance	OFF → ON (Sao)	10 mm Close	
	ON → OFF (Sar)	20 mm Open	
Actuator approach speed	Min.	4 mm/s	
	Max.	1,000 mm/s	
Operating temperature		-25 to 105°C	
Enclosure protection	Flying lead	IP69K	
	M12 connector	IP67	
Material		UL approved Polyester	

Electrical data

Item	Model	Elongated sensor	Small sensor
Power supply		24 VDC±15%	
Power consumption	Max.	0.2 A	
	Min.	1 mA, 10 VDC	
Rated loads	NC contacts	Max. 0.2 A, 24 VDC	
	NO contact	Max. 0.2 A, 24 VDC	
Output type		Electronic output (potential-free optocoupler output)	

Approved standards

EN standards certified by TÜV Rheinland
EN 954-1, EN ISO13849-1
EN 60204-1
EN/IEC 60947-5-3
UL 508, CSA C22.2
BS 5304
EN 1088-1 conformance

Wiring examples (Single head connection)

G9SA

Single sensor application with G9SA-301
(up to PLe acc. EN ISO 13849-1)

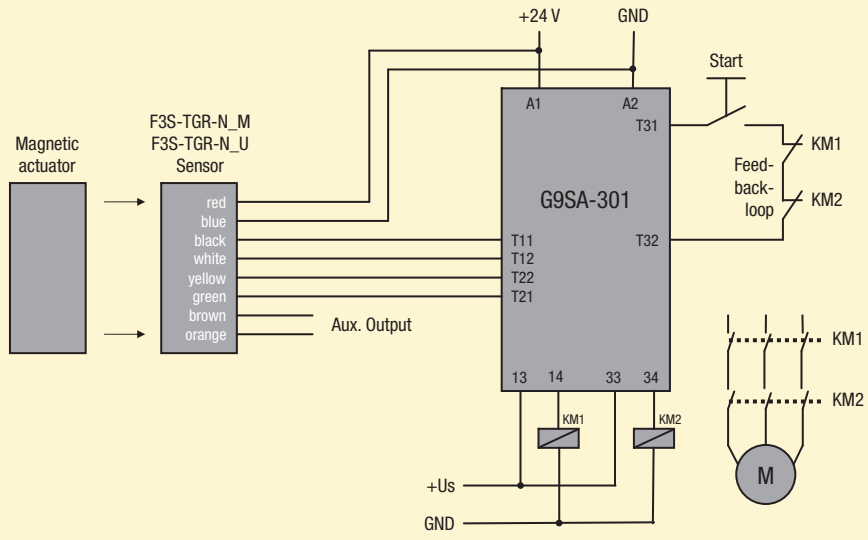



Explosion proof non-contact switches

Non-contact switches monitor the status of guarding doors or the position of linear systems in applications in explosive environment.

The design includes wear-free non-contact operation for extended operation time and a robust mechanical setup to cover mechanical tolerances and vibrations.

- Connect up to 6 switches in series
- Operates behind stainless steel fittings
- Suitable for high pressure cleaning, CIP and SIP processes due IP69K (pre-wired types)
- Conforms to safety categories up to PLe acc. EN ISO 13849-1

Ordering information

Elongated sensors

Type	Cable connection	Contact configuration	Order code
	5 m pre-wired	2NC/1NO	F3S-TGR-NLMX-21-05
	10 pre-wired	2NC/1NO	F3S-TGR-NLMX-21-10

Barrel sensors

Type	Cable connection	Contact configuration	Order code
	5 m pre-wired	2NC/1NO	F3S-TGR-NBMX-21-05
	10 pre-wired	2NC/1NO	F3S-TGR-NBMX-21-10

Specifications

Mechanical data

Item	Model	Elongated sensors	Barrel sensors
Operating distance	OFF → ON (Sao)	10 mm close	
	ON → OFF (Sar)	22 mm open	
Actuator approach speed	Min.	4 mm/s	
	Max.	1000 mm/s	
Operating temperature	–	–20°C to +60°C	
Enclosure protection	Flying lead	IP 67	
Material	–	Stainless steel 316	

Electrical data

Item	Model	Elongated sensors	Barrel sensors
Power supply	–	24 VDC ±15%	
Switching current	Min.	1 mA, 10 VDC	
Rated loads	NC contacts	Max.	0.6 A, 230 VAC/24 VDC (internally fused)
	NO contact		

Ex specification

Ex specification
II 2G Ex mb IIC T6Gb, II 2D Ex mb IIC T80 Db IP67* (*Product is fully encapsulated which is considered to provide Ingress Protection to at least IP67)
Zone 1 Gas, Zone 21 Dust, Zone 2 Gas, Zone 21 Dust (An area where Gas and Dust is likely to occur in use)
IEC/EN 60079-0, IEC/EN 60079-18

Approved standards

EN standards certified by TÜV Rheinland
EN 954-1, EN ISO13849-1
EN 60204-1
EN/IEC 60947-5-3
UL 508, CSA C22.2
BS 5304
EN 1088-1

Wiring examples (Single head connection)

G9SA

Single sensor application with G9SA-301
(up to PLe acc. EN ISO 13849-1)

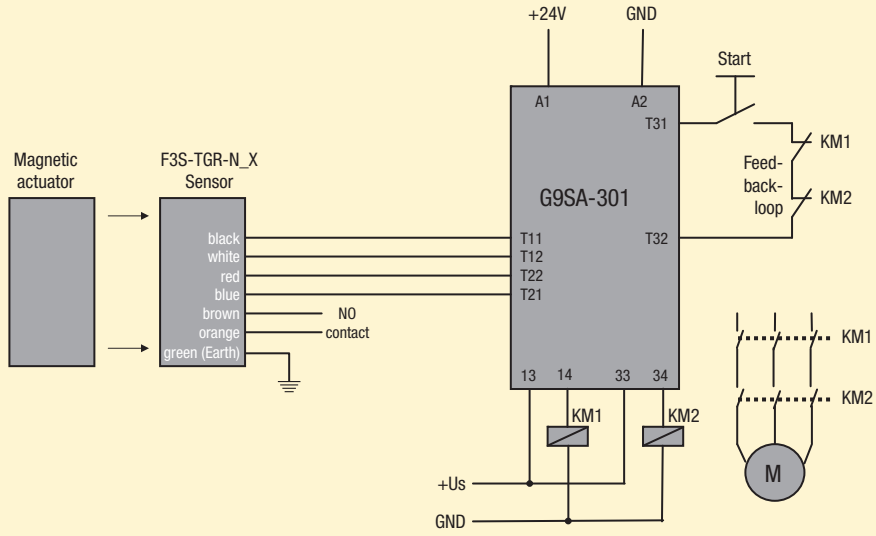



Safety door switch with plastic housing

The D4NS line-up includes three-contact models with 2NC/1NC and 3NC contact forms in addition to the previous contact forms, 1NC/1NO and 2NC. All models have a M20 conduit opening.





- Line-up with three contacts: 2NC/1NC and 3NC contact forms
- Line-up with two contacts 1NC/1NO and 2NC
- Standardised gold-clad contacts for high contact reliability
- Applicable for standard loads and micro loads

Ordering information

Switches (with approved direct opening contacts)

Type	Contact configuration		Conduit opening/connector	Order code
1-conduit	Slow-action	1NC/1NO	M20	D4NS-4AF
		2NC	M20	D4NS-4BF
		2NC/1NO	M20	D4NS-4CF
		3NC	M20	D4NS-4DF
	Slow-action MBB contact	1NC/1NO	M20	D4NS-4EF
		2NC/1NO	M20	D4NS-4FF

Operation keys (order separately)

Type		Order code	Type		Order code
Horizontal mounting		D4DS-K1	Adjustable mounting (horizontal)		D4DS-K3
Vertical mounting		D4DS-K2	Adjustable mounting (horizontal/vertical)		D4DS-K5

Specifications

Degree of protection		IP67 (EN60947-5-1) (This applies for the switch only. The degree of protection for the key hole is IP00.)
Durability *1	Mechanical	1,000,000 operations min.
	Electrical	500,000 operations min. for a resistive load of 3 A at 250 VAC 300,000 operations min. for a resistive load of 10 A at 250 VAC
Operating speed		0.05 to 0.5 m/s
Operating frequency		30 operations/minute max.
Direct opening force *2		60 N min.
Direct opening travel *2		10 mm min.
Minimum applicable load		Resistive load of 1 mA at 5 VDC (N-level reference value)
Protection against electric shock		Class II (double insulation)
Pollution degree (operating environment)		3 (EN60947-5-1)
Contact gap		2×2 mm min
Conditional short-circuit current		100 A (EN60947-5-1)
Rated open thermal current (I_{th})		10 A (EN60947-5-1)
Ambient temperature		Operating: -30°C to 70°C with no icing

*1 The durability is for an ambient temperature of 5°C to 35°C and an ambient humidity of 40 to 70%. For more details, consult your Omron representative.

*2 These figures are minimum requirements for safe operation.

Note: The above values are initial values.



Safety door switch with metal housing

The D4BS line-up includes two-contact models with 1NC/1NO and 2NC in a robust metal housing with 1 PG 13.5 conduit opening.



- Robust metal housing
- Line-up with two contacts: 1NC/1NO and 2NC
- Standardised gold-clad contacts for high contact reliability
- Applicable for standard loads and micro loads

Ordering information

Switches

Type	Mounting direction	Conduit size	Order code	
			1NC/1NO (slow-action)	2NC (slow-action)
1-conduit	Front-side mounting	Pg13.5	D4BS-15FS	D4BS-1AFS

Operation keys (order separately)

Type		Order code
Horizontal mounting		D4BS-K1
Vertical mounting		D4BS-K2
Adjustable mounting (horizontal)		D4BS-K3

Specifications

Degree of protection ^{*1}	IP67 (EN60947-5-1)
Durability ^{*2}	Mechanical: 1,000,000 operations min. Electrical: 500,000 operations min. (10 A at 250 VAC, resistive load)
Operating speed	0.1 m/s to 0.5 m/s
Operating frequency	30 operations/min max.
Rated frequency	50/60 Hz
Contact gap	2×2 mm min.
Direct opening force ^{*3}	19.61 N min. (EN60947-5-1)
Direct opening travel ^{*3}	20 mm min. (EN60947-5-1)
Full stroke	23 mm min.
Conventional enclosed thermal current (I _{th})	20 A (EN60947-5-1)
Conditional short-circuit current	100 A (EN60947-5-1)
Pollution degree (operating environment)	3 (EN60947-5-1)
Protection against electric shock	Class I (with ground terminal)
Ambient temperature	Operating: -40 to 80°C (with no icing)

^{*1} Although the switch box is protected from dust, oil, or water penetration, do not use the D4BS in places where dust, oil, water, or chemicals may penetrate through the key hole on the head, otherwise switch damage or malfunctioning may occur.

^{*2} The durability is for an ambient temperature of 5°C to 35°C and an ambient humidity of 40 to 70%. Contact your Omron sales representative for more detailed information on other operating environments.

^{*3} These figures are minimum requirements for safe operation.

Note: The above values are initial values.



Guard-lock safety door switch

The D4NL guard-lock safety-door switches are available with four or five built-in contacts. When locked, they have a key holding force of up to 1300 N. Mechanical lock/solenoid release types and vice versa set up the complete range.

- Safety-door switch with electromagnetic lock or unlock mechanism
- Models with four or five built-in contacts
- Strong key holding force: 1300 N
- For standard loads and micro loads
- Keys are compatible with D4GL and D4NS

Ordering information

Switches (with approved direct opening contacts)

For 110V and 230V version ask your local Omron representative

Lock and release types	Contact configuration	Conduit opening	Order code
Mechanical lock solenoid release	1NC/1NO + 1NC/1NO	M20	D4NL-4AFA-B
	1NC/1NO + 2NC	M20	D4NL-4BFA-B
	2NC + 1NC/1NO	M20	D4NL-4CFA-B
	2NC + 2NC	M20	D4NL-4DFA-B
	2NC/1NO + 1NC/1NO	M20	D4NL-4EFA-B
	2NC/1NO + 2NC	M20	D4NL-4FFA-B
	3NC + 1NC/1NO	M20	D4NL-4GFA-B
	3NC + 2NC	M20	D4NL-4HFA-B

Lock and release types	Contact configuration	Conduit opening	Order code
Solenoid lock mechanical release	1NC/1NO + 1NC/1NO	M20	D4NL-4AFG-B
	1NC/1NO + 2NC	M20	D4NL-4BFG-B
	2NC + 1NC/1NO	M20	D4NL-4CFG-B
	2NC + 2NC	M20	D4NL-4DFG-B
	2NC/1NO + 1NC/1NO	M20	D4NL-4EFG-B
	2NC/1NO + 2NC	M20	D4NL-4FFG-B
	3NC + 1NC/1NO	M20	D4NL-4GFG-B
	3NC + 2NC	M20	D4NL-4HFG-B

Note: - Conduit sizes of G1/2 and Pg 13,5 are also available.
 - Solenoid: 24 VDC, Orange LED: 10 to 115 VAC/VDC

Operation keys (order separately)

Type		Order code
Horizontal mounting		D4DS-K1
Vertical mounting		D4DS-K2

Type		Order code
Adjustable mounting (horizontal)		D4DS-K3
Adjustable mounting (horizontal/vertical)		D4DS-K5

Specifications

Degree of protection	IP67 (EN60947-5-1) (This applies for the switch only. The degree of protection for the key hole is IP00.)	
Durability ^{*1}	Mechanical	1,000,000 operations min.
	Electrical	500,000 operations min. for a resistive load of 3 A at 250 VAC
Operating speed	0.05 to 0.5 m/s	
Operating frequency	30 operations/minute max.	
Rated frequency	50/60 Hz	
Contact gap	2x2 mm min	
Direct opening force ^{*2}	60 N min. (EN60947-5-1)	
Direct opening travel ^{*2}	10 mm min. (EN60947-5-1)	
Holding force	1,300 N min.	
Minimum applicable load	Resistive load of 1 mA at 5 VDC (N-level reference value)	
Thermal current (I_{th})	10 A (EN60947-5-1)	
Conditional short-circuit current	100 A (EN60947-5-1)	
Pollution degree (operating environment)	3 (EN60947-5-1)	
Protection against electric shock	Class II (double insulation)	
Ambient temperature	Operating: -10°C to 55°C (with no icing or condensation)	

^{*1} The durability is for an ambient temperature of 5°C to 35°C and an ambient humidity of 40 to 70%. For more details, consult your Omron representative.

^{*2} These figures are minimum requirements for safe operation.

Note: The above values are initial values.



Guard-lock safety door switch

The D4GL guard-lock safety-door switches are available with four or five built-in contacts. When locked, they have a key holding force of up to 1000 N. Mechanical lock/solenoid release types and vice versa set up the complete range.

- Slim safety-door switch with electromagnetic lock or unlock mechanism
- Models with four or five built-in contacts
- Strong key holding force: 1000 N
- For standard loads and micro loads
- Keys are compatible with D4NL and D4NS

Ordering information

Switches (with approved direct opening contacts)

Lock and release types	Contact configuration	Conduit size	Order code
Mechanical lock solenoid release	1NC/1NO + 1NC/1NO	M20	D4GL-4AFA-A
	1NC/1NO + 2NC	M20	D4GL-4BFA-A
	2NC + 1NC/1NO	M20	D4GL-4CFA-A
	2NC + 2NC	M20	D4GL-4DFA-A
	2NC/1NO + 1NC/1NO	M20	D4GL-4EFA-A
	2NC/1NO + 2NC	M20	D4GL-4FFA-A
	3NC + 1NC/1NO	M20	D4GL-4GFA-A
	3NC + 2NC	M20	D4GL-4HFA-A

Lock and release types	Contact configuration	Conduit size	Order code
Solenoid lock mechanical release	1NC/1NO + 1NC/1NO	M20	D4GL-4AFG-A
	1NC/1NO + 2NC	M20	D4GL-4BFG-A
	2NC + 1NC/1NO	M20	D4GL-4CFG-A
	2NC + 2NC	M20	D4GL-4DFG-A
	2NC/1NO + 1NC/1NO	M20	D4GL-4EFG-A
	2NC/1NO + 2NC	M20	D4GL-4FFG-A
	3NC + 1NC/1NO	M20	D4GL-4GFG-A
	3NC + 2NC	M20	D4GL-4HFG-A

Note: - conduit sizes of G1/2 and Pg13,5 are also available.
- solenoid: 24 VDC, orange/green LED: 24 VDC

Operation keys (order separately)

Type		Order code
Horizontal mounting		D4DS-K1
Vertical mounting		D4DS-K2

Type		Order code
Adjustable mounting (horizontal)		D4DS-K3
Adjustable mounting (horizontal/vertical)		D4DS-K5

Specifications

Degree of protection		IP67 (EN60947-5-1) (This applies for the switch only. The degree of protection for the key hole is IP00.)
Durability *1	Mechanical	1,000,000 operations min.
	Electrical	500,000 operations min. for a resistive load of 4 mA at 24 VDC; 150,000 operations min. for a resistive load of 1 A at 125 VAC in 2 circuits and 4 mA at 24 VDC in 2 circuits
Operating speed		0.05 to 0.5 m/s
Operating frequency		30 operations/minute max.
Rated frequency		50/60 Hz
Contact gap		2x2 mm min.
Direct opening force *2		60 N min. (EN60947-5-1)
Direct opening travel *3		10 mm min. (EN60947-5-1)
Holding force		1,000 N min.
Minimum applicable load		Resistive load of 4 mA at 24 VDC (N-level reference value)
Thermal current (I_{th})		2.5 A (EN60947-5-1)
Conditional short-circuit current		100 A (EN60947-5-1)
Pollution degree (operating environment)		3 (EN60947-5-1)
Protection against electric shock		Class II (double insulation)
Ambient temperature		Operating: -10°C to 55°C with no icing

*1 The durability is for an ambient temperature of 5°C to 35°C and an ambient humidity of 40 to 70%. For more details, consult your Omron representative.

*2 These figures are minimum requirements for safe operation.

*3 These figures are minimum requirements for safe operation.

Note: The above values are initial values.



Guard-lock safety door switch

The D4SL-N guard-lock safety door switches safety door switches provides a wide range of models for the safe monitoring of entries and positions of guards.

- Key holding force 1,300 N
- 4, 5 and 6 contact types
- Terminal block type and connector type
- Drive solenoid directly from the controller
- Turning key insertion point without detaching head

Ordering information

Contact configuration

Contact model	Built-in Switch
4-contact model	Door monitor and Lock monitor are connected in series internally. A: 1NC/1NO + 1NC/1NO B: 1NC/1NO + 2NC C: 2NC + 1NC/1NO D: 2NC + 2NC
	Door monitor and Lock monitor are NOT connected in series internally. S: 1NC/1NO + 1NC/1NO T: 1NC/1NO + 2NC U: 2NC + 1NC/1NO V: 2NC + 2NC

Contact model	Built-in Switch
5-contact model	E: 2NC/1NO + 1NC/1NO
	F: 2NC/1NO + 2NC
	G: 3NC + 1NC/1NO
	H: 3NC + 2NC
6-contact model	N: 2NC/1NO + 2NC/1NO
	P: 2NC/1NO + 3NC
	Q: 3NC + 2NC/1NO
	R: 3NC + 3NC

Models







Housing	Release key type	Wiring method	Solenoid voltage/ Indicator	Lock and release type	Contact configuration (door open/closed detection switch and lock monitor switch contacts)	Conduit size ^{*1}	Order code	
Head Resin/ Body Resin ^{*2}	Standard (metal) ^{*3} 	Connector	24 VDC (Orange)	Mechanical lock Solenoid release	6-contact Model Insert the built-in switch (N, P, Q or R) into the blank _.	M20	D4SL-N4_FA-DN	
					5-contact Model Insert the built-in switch (E, F, G or H) into the blank _.	M20	D4SL-N4_FA-DN	
			4-contact Model Insert the built-in switch (A, B, C, D, S, T, U or V) into the blank _.		M20	D4SL-N4_FA-N		
			Terminal block		24 VDC (without indicator)	6-contact Model Insert the built-in switch (N, P, Q or R) into the blank _.	M20	D4SL-N4_FA-D
						5-contact Model Insert the built-in switch (E, F, G or H) into the blank _.	M20	D4SL-N4_FA-D
			4-contact Model Insert the built-in switch (A, B, C, D, S, T, U or V) into the blank _.		M20	D4SL-N4_FA		
		Connector	24 VDC (Orange)	Solenoid lock Mechanical release	6-contact Model Insert the built-in switch (N, P, Q or R) into the blank _.	M20	D4SL-N4_FG-DN	
					5-contact Model Insert the built-in switch (E, F, G or H) into the blank _.	M20	D4SL-N4_FG-DN	
			4-contact Model Insert the built-in switch (A, B, C, D, S, T, U or V) into the blank _.		M20	D4SL-N4_FG-N		
			Terminal block		24 VDC (without indicator)	6-contact Model Insert the built-in switch (N, P, Q or R) into the blank _.	M20	D4SL-N4_FG-D
						5-contact Model Insert the built-in switch (E, F, G or H) into the blank _.	M20	D4SL-N4_FG-D
			4-contact Model Insert the built-in switch (A, B, C, D, S, T, U or V) into the blank _.		M20	D4SL-N4_FG		

^{*1} Types also with G1/2 and 1/2-14NPT available - see online data sheet

^{*2} 'Head metal/Body resin' also available - see online data sheet

^{*3} Release key type also resin available - see online data sheet

Operation keys (order separately)

Type	Order code	Type	Order code
Horizontal mounting 	D4SL-NK1	Vertical mounting 	D4SL-NK2
Horizontal mounting (Short) 	D4SL-NK1S	Vertical mounting (Cushion rubber) 	D4SL-NK2G
Horizontal mounting (Cushion rubber) 	D4SL-NK1G	Adjustable (Horizontal) 	D4SL-NK3

Connector cables for connector types

Cable length	Order code
1 m	D4SL-CN1
3 m	D4SL-CN3
5 m	D4SL-CN5

Specifications

Degree of protection ^{*1}	IP67 (EN60947-5-1)	
Durability ^{*2}	Mechanical	1,000,000 operations min.
	Electrical	150,000 operations min. (1 A resistance at 125 VAC) ^{*3}
Operating speed	0.05 to 1 m/s	
Operating frequency	5 operations minute max.	
Direct opening force ^{*4}	60 N min. (EN60947-5-1)	
Direct opening travel ^{*4}	15 mm min. (EN60947-5-1)	
Holding force	1,300 N min.	
Minimum applicable load	1 mA resistive load at 5 VDC (N-level reference value)	
Rated insulation voltage (Ui)	150 V (EN60947-5-1)	
Rated frequency	50/60 Hz	
Protection against electric shock	Class II (double insulation)	
Pollution degree (operating environment)	3 (EN60947-5-1)	
Conditional short-circuit current	100 A (EN60947-5-1)	
Conventional free air thermal current (Ith)	2.5 A (11-42, 21-52, 21-22) 1 A (Others)	
Ambient operating temperature	-10 to 55°C (with no icing)	
Ambient operations humidity	95% max.	

^{*1} This applies for the switch only. The degree of protection for the key hole is IP00.

^{*2} The durability is for an ambient temperature of 5 to 35°C and an ambient humidity of 40% to 70%. For more details, consult your OMRON representative.

^{*3} Do not pass the 1 A, 125 VAC load through more than 3 circuits.

^{*4} These figures are minimum requirements for safe operation.

Note: 1. The above values are initial values.
2. The switch contacts can be used with either standard loads or microloads.

PROTECT OPERATORS AND PRODUCTION

Total consistency across the board

Safety Sensors are the first choice in safeguarding workplaces where persons and machines cooperate. Built-in intelligence stops the machine in conditions that are dangerous for the worker. Our F3S-TGR-CL and F3SJ range offers safety light curtains with included safe control functions for finger-, hand- and body protection.

- Finger- and Hand and body protection models
- Control functions
 - X-, T- and L-muting
 - fixed and floating blanking
 - single and double break operation
 - pre-reset access control
- Easy mounting and common wiring for all types for simple design and installation
- Certified acc. EN61496 and EN ISO 13849-1.

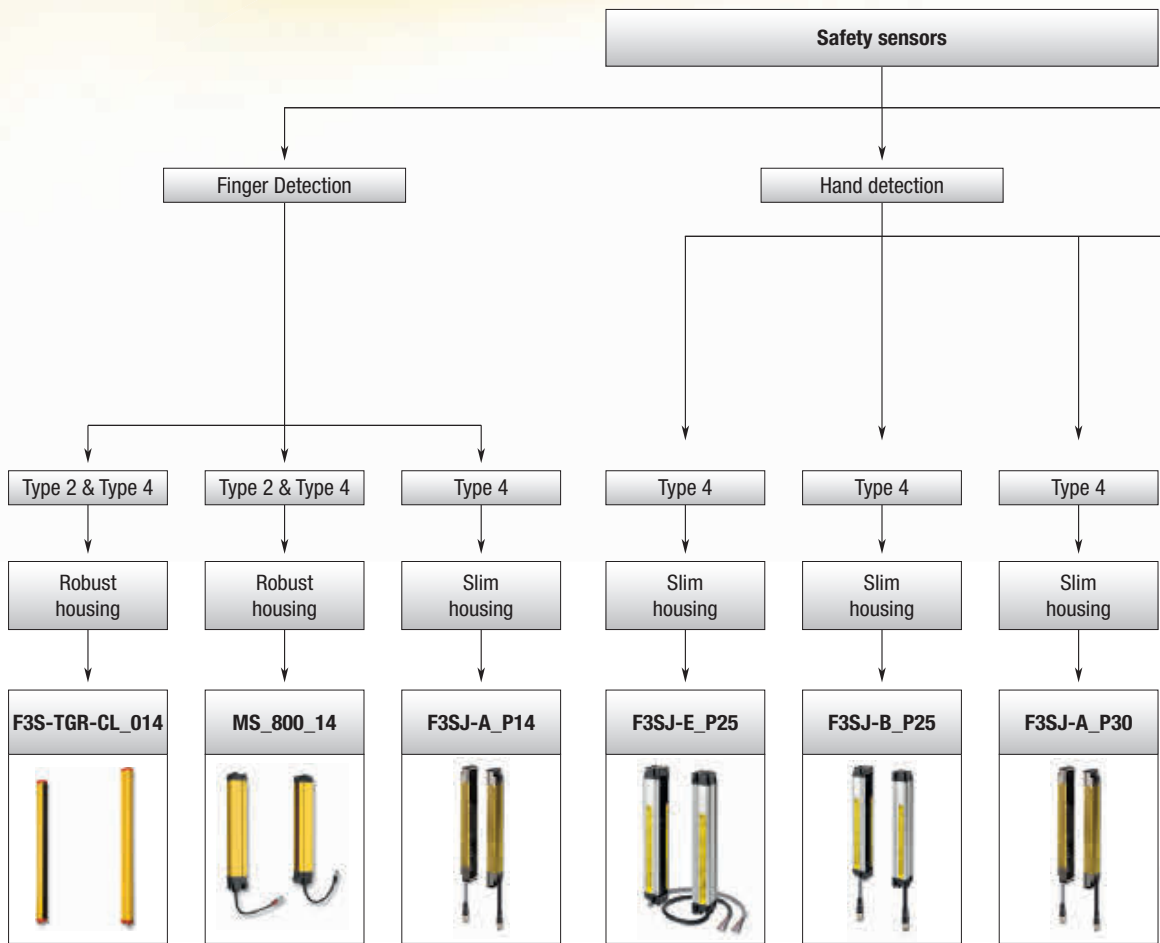

Page 507

Page 505

Page 499

Page 491

Page 495

Page 499

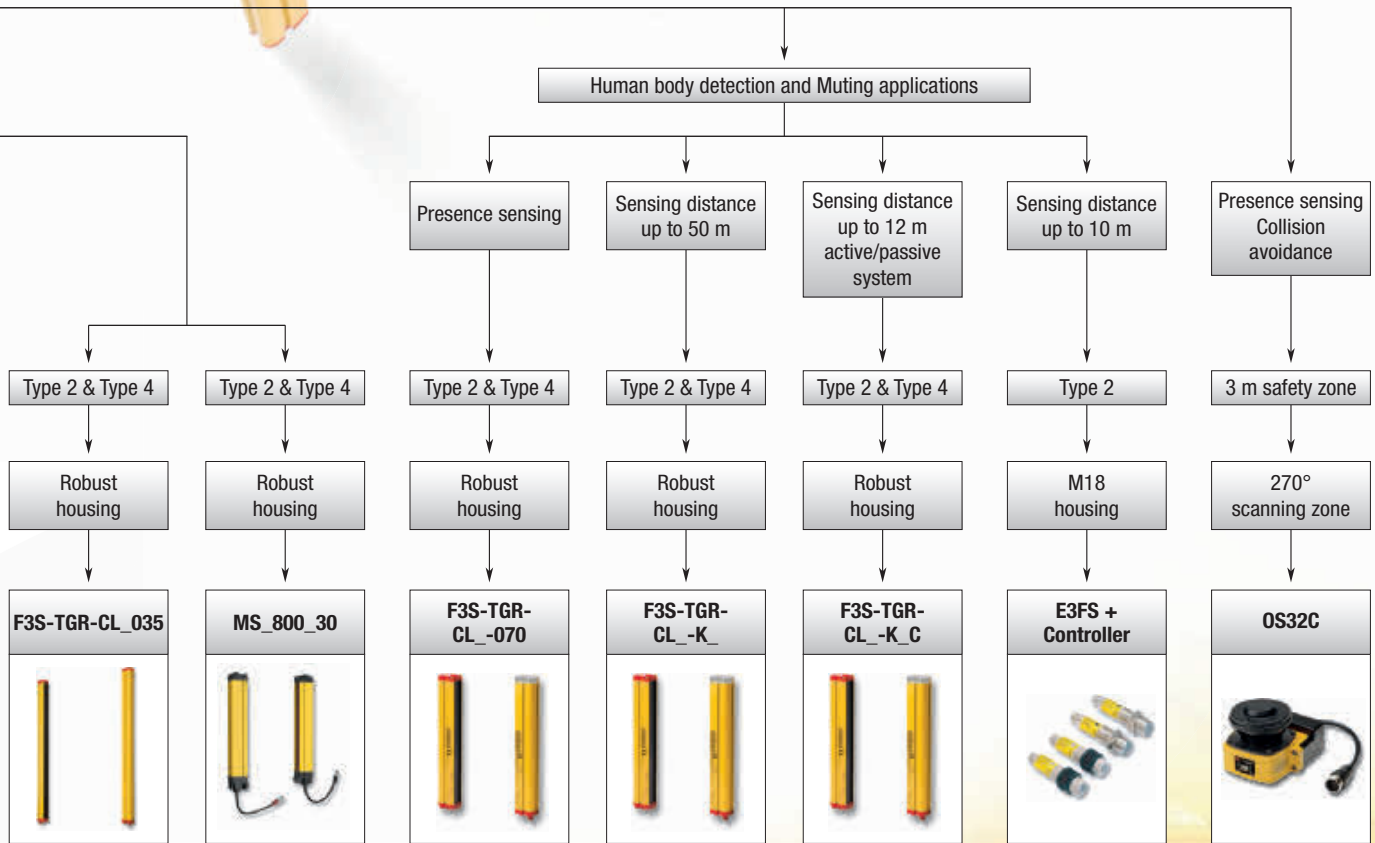

Page 507

Page 505

Page 507





Page 507

Page 507

Page 514

Page 515

Selection table

		Safety Sensors			
					
		F3SJ-E	F3SJ-B	F3SJ-A	MS2800 and MS4800
Selection criteria	Model	Type 4	Type 4	Type 4	Type 2 & 4
	Safety category	Type 4	Type 4	Type 4	Type 2 & 4
	Safety integrity level (IEC 61508)	–	–	–	SIL 3
	Protective height	185 to 1,105 mm	185 to 2,065 mm	245 to 2,495 mm	280 to 2,120 mm
	Resolution	25 mm	25 mm	14, 30 mm	14, 30 mm
	Reaction time	15 ms	15 ms	10 to 25 ms	14 to 59 ms
	Temperature range	–10 to 55°C	–10 to 55°C	–10 to 55°C	–10 to 55°C
Features	IP class	IP65	IP65	IP65	IP65
	Blanking function	–	–	internal	internal
	Muting function	–	■	–	option
	EDM function	internal	internal	internal	internal
	Interlock function	–	internal	internal	internal
	Series connection	–	option	option	option
	Mounting kits	option	option	inclusive	option
Application	Parameter setting	–	–	option (Console)	internal DIP switch
	External control unit	–	–	–	–
	Finger protection	–	–	■	■
	Hand protection	■	■	■	■
	Arm protection	■	■	■	■
	Body protection	■	■	■	■
	Presence detection	–	–	–	■
Supply voltage	Muting application	–	–	–	–
	Blanking application	–	–	■	■
	24 VDC	■	■	■	■
In- and Outputs	Safety outputs	2 PNP OSSD transistor outputs	2 PNP OSSD transistor outputs	2 PNP OSSD transistor outputs	2 PNP OSSD transistor outputs
	Auxiliary output	–	1 PNP (non safety)	2 PNP (non safety)	1 PNP (non safety)
	Test input	■	■	■	■
	EDM input	■	–	■	■
	Reset input	■	–	■	■
Muting sensor input	–	–	–	–	
Page	491	495	499	505	

				Safety Sensors	
					
		F3S-TGR-CL	F3S-TGR-CL-K_ / -K_C	E3FS + F3SP-U3P	OS32C
Selection criteria	Model	F3S-TGR-CL	F3S-TGR-CL-K_ / -K_C	E3FS + F3SP-U3P	OS32C
	Safety category	Type 2 & 4	Type 2 & 4	Type 2	Type 3
	Safety integrity level (IEC 61508)	–	–	–	SIL 2
	Protective height	150 to 2,400 mm	500 to 1,200 mm	–	Scanning range 3 m
	Resolution	14, 35, 70 mm	–	–	–
	Beam pitch	–	300, 400, 500 mm	–	–
	Reaction time	13 to 103 ms	13 ms	32 ms	80 ms
	Temperature range	–10 to 55°C	–10 to 55°C	–10 to 55°C	–10 to 50°C
Features	IP class	IP65	IP65	IP67	IP65
	Blanking function	internal	–	–	–
	Muting function	internal	internal	option	–
	EDM function	internal	internal	option	internal
	Interlock function	internal	internal	option	internal
	Series connection	option	–	–	–
	Mounting kits	option	option	■	option
	Parameter setting	internal DIP switch	internal DIP switch	–	Software (included)
Application	External control unit	–	–	■	–
	Finger protection	■	–	–	–
	Hand protection	■	–	–	–
	Arm protection	■	–	–	–
	Body protection	■	■	■	■
	Presence detection	■	–	–	■
	Muting application	■	■	■	–
Supply voltage	Blanking application	■	–	–	–
	24 VDC	■	■	■	–
In- and Outputs	Safety outputs	2 PNP OSSD transistor outputs	2 PNP OSSD transistor outputs	2 PNP OSSD transistor outputs	2 PNP OSSD transistor outputs
	Auxiliary output	–	–	–	■
	Test input	■	■	■	–
	EDM input	■	■	–	■
	Reset input	■	■	■	■
	Muting sensor input	■	■	■	–
	Page	507	507	514	515



Easy type for simple and affordable hand protection

The F3SJ-E-family is a type 4 safety light curtain with an optical resolution of 25 mm. An operation range of up to 7 m and a protective height up to 1,105 mm are provided with no dead zone

- Detection height = sensor height
- Small housing
- Simple and affordable hand protection
- Reduced wiring, quick mount brackets and easy-to-view-alignment beams reduce mounting time
- Type 4 sensor complying with EN 61496-1 and up to PLe according EN ISO 13849

Ordering information

Application	Detection capability	Beam gap	Operating range	Protective height(mm)	Order code
Hand protection	Dia. 25 mm	20 mm	0.2 to 7 m	185 to 1,105	F3SJ-E____P25







Note: F3SJ-E uses a 3 m prewired discrete cable.

Number of beams	Protective height (mm) ^{*1}	Order code
8	185	F3SJ-E0185P25
10	225	F3SJ-E0225P25
14	305	F3SJ-E0305P25
18	385	F3SJ-E0385P25
22	465	F3SJ-E0465P25
26	545	F3SJ-E0545P25
30	625	F3SJ-E0625P25
34	705	F3SJ-E0705P25
38	785	F3SJ-E0785P25
42	865	F3SJ-E0865P25
46	945	F3SJ-E0945P25
50	1,025	F3SJ-E1025P25
54	1,105	F3SJ-E1105P25

^{*1} Protective height (mm) = Total sensor length

Accessories (sold separately)

Sensor mounting bracket

Appearance	Specifications	Application	Remarks	Order code
	Top/bottom bracket	Top/bottom bracket for F3SJ-E/B	2 for an emitter, 2 for a receiver, total of 4 per set	F39-LJB1
	Intermediate bracket	In combination use with top/bottom bracket for F3SJ-E/B Can be used as free-location bracket.	1 set with 2 pieces	F39-LJB2 ^{*1} ^{*2}
	Quick mount bracket	Quick mount bracket for F3SJ-E/B Supports M6 slide nut for aluminum frame.	1 set with 2 pieces	F39-LJB3-M6 ^{*1}
	Quick mount bracket	Quick mount bracket for F3SJ-E/B Supports M8 slide nut for aluminum frame.		F39-LJB3-M8 ^{*2}
	Quick mount M6 bracket	Bracket to mount an intermediate bracket to the aluminum frame with a single touch.	Hexagon socket head cap screws (M6 × 10) are included.	F39-LJB3-M6K ^{*1}
	Quick mount M8 bracket			Hexagon socket head cap screws (M8 × 14) are included.
	Compatible mounting bracket	Mounting bracket used when replacing existing area sensors (F3SJ-A or F3SN) with the F3SJ-E/B.	2 for an emitter, 2 for a receiver, total of 4 per set	F39-LJB4
	Contact mount bracket	Bracket to closely contact the back side of the sensor.	2 for an emitter, 2 for a receiver, total of 4 per set	F39-LJB5

^{*1} Combining F39-LJB2 and F39-LJB3-M6K makes F39-LJB3-M6.

^{*2} Combining F39-LJB2 and F39-LJB3-M8K makes F39-LJB3-M8.

Laser pointer

Appearance	Output	Order code
	Laser pointer for F3SJ	F39-PTJ

Specifications

Model	F3SJ-E	P25
Sensor type	Type 4 safety light curtain	
Setting tool connection ^{*1}	Parameter settings: Not available	
Safety category	Safety purpose of category 4, 3, 2, 1, or B	
Detection capability	Opaque objects 25 mm in diameter	
Beam gap (P)	20 mm	
Number of beams (n)	8 to 54	
Protective height (PH)	185 to 1,105 mm	
Lens diameter	Diameter 5 mm	
Operating range ^{*2}	0.2 to 7 m	
Response time (under stable light incident condition)	ON to OFF	15 ms max.
	OFF to ON	70 ms max.
Startup waiting time	2 s max.	
Power supply voltage (Vs)	SELV/PELV 24 VDC±20% (ripple p-p 10% max.)	
Consumption current (no load)	Emitter: Up to 22 beams: 41 mA max., 26 to 42 beams: 57 mA max., 46 to 54 beams: 63 mA max. Receiver: Up to 22 beams: 42 mA max., 26 to 42 beams: 47 mA max., 46 to 54 beams: 51 mA max.	
Light source (emitted wavelength)	Infrared LED (870 nm)	
Effective aperture angle (EAA)	Based on IEC 61496-2. Within ±2.5° for both emitter and receiver when the detection distance is 3 m or over	
Safety outputs (OSSD)	Two PNP transistor outputs, load current 200 mA max., residual voltage 2 V max. (except for voltage drop due to cable extension), Leakage current 1 mA max., load inductance 2.2 H max. ^{*3} , Maximum capacity load 1 μF ^{*4}	
Output operation mode	Safety output: On when receiving light	
Input voltage	ON voltage: Vs-3 V to Vs, OFF voltage: 0 V to 1/2 Vs or open ^{*5}	
Mutual interference prevention function	Mutual interference prevention algorithm prevents interference in up to 3 sets.	
Test function	Self test (at power-ON and at power distribution) External test (emission stop function by test input)	
Protection circuit	Output short-circuit protection, and power supply reverse polarity protection	
Ambient temperature	Operating: -10 to 55°C (non-freezing), Storage: -25 to 70°C	
Ambient humidity	Operating: 35% to 85% (no condensation), Storage: 35% to 95% RH	
Operating ambient light intensity	Incandescent lamp: 3,000 lx max., Sunlight: 10,000 lx max.	
Insulation resistance	20 MΩ min. (at 500 VDC)	
Dielectric strength	1,000 VAC 50/60 Hz, 1 min	
Degree of protection	IP65 (IEC 60529)	
Vibration resistance	Malfunction: 10 to 55 Hz, Multiple amplitude of 0.7 mm, 20 sweeps in X, Y, and Z directions	
Shock resistance	Malfunction: 100 m/s ² , 1,000 times each in X, Y, and Z directions	
Pollution degree	Pollution degree 3 (IEC 60664-1)	
Power cable	Connection method: Pull-out type, cable length 3 m Number of wires: Emitter: 5 wires, receiver: 6 wires Cable diameter: Dia. 6 mm Allowable bending radius: R5 mm	
Extension cable	30 m max. ^{*6}	
Material	Case: Aluminum Cap: ABS resin, PBT Optical cover: PMMA resin (acrylic) Cable: Oil resistant PVC	
Weight (packed state)	Weight (g) = (protective height) × 2.6 + 800	
Accessories	Test rod, Instruction Manual, User's Manual (CD-ROM) ^{*7}	
Applicable standards	IEC 61496-1, EN 61496-1 UL 61496-1, Type 4 ESPE (Electro-Sensitive Protective Equipment) IEC 61496-2, CLC/TS 61496-2, UL 61496-2, Type 4 AOPD (Active Opto-electronic Protective Devices) IEC 61508-1 to -3, EN 61508-1 to -3 SIL3 IEC 13849-1: 2006, EN ISO 13849-1: 2008 (PLe, Cat.4) UL 508, UL 1998, CAN/CSA C22.2 No.14, CAN/CSA C22.2 No.0.8	

^{*1} Do not use the support software and setting console for F3SJ-A. Operation cannot be guaranteed.

^{*2} Use of the spatter protection cover causes a 10% maximum sensing distance attenuation.

^{*3} The load inductance is the maximum value when the safety output frequently repeats ON and OFF. When you use the safety output at 4 Hz or less, the usable load inductance becomes larger.

^{*4} These values must be taken into consideration when connecting elements including a capacitive load such as capacitor.

^{*5} The Vs indicates a voltage value in your environment.

^{*6} To extend a cable of the F3SJ-E, refer to the user's manual (SCHG-733/732).

^{*7} Mounting brackets are sold separately.

Connections

Basic wiring diagram

Minimum wiring required to check the operation of the F3SJ-E

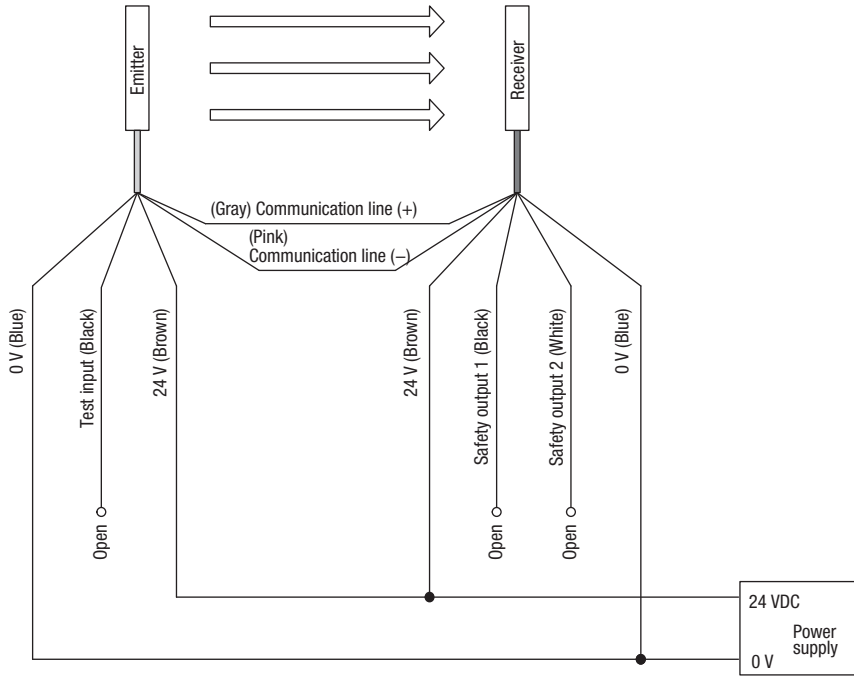



Basic type with a combination of performance and functionality

The F3SJ-B-family is a type 4 safety light curtain with an optical resolution of 25 mm. An operation range of up to 7 m and a protective height up to 2,065 mm are provided with no dead zone

- Detection height = sensor height
- Simple hand protection
- Muting function available
- Series connection up to three sets
- Type 4 sensor complying with EN 61496-1 and up to PLe according EN ISO 13849

Ordering information







Application	Detection capability	Beam gap	Operating range	Protective height (mm)	Order code
Hand protection	Dia. 25 mm	20 mm	0.2 to 7 m	185 to 2,065	F3SJ-B____P25

Number of beams	Protective height (mm) ^{*1}	Order code
8	185	F3SJ-B0185P25
10	225	F3SJ-B0225P25
14	305	F3SJ-B0305P25
18	385	F3SJ-B0385P25
22	465	F3SJ-B0465P25
26	545	F3SJ-B0545P25
30	625	F3SJ-B0625P25
34	705	F3SJ-B0705P25
38	785	F3SJ-B0785P25
42	865	F3SJ-B0865P25
46	945	F3SJ-B0945P25
50	1,025	F3SJ-B1025P25
54	1,105	F3SJ-B1105P25
58	1,185	F3SJ-B1185P25
62	1,265	F3SJ-B1265P25
66	1,345	F3SJ-B1345P25
70	1,425	F3SJ-B1425P25
74	1,505	F3SJ-B1505P25
78	1,585	F3SJ-B1585P25
82	1,665	F3SJ-B1665P25
86	1,745	F3SJ-B1745P25
90	1,825	F3SJ-B1825P25
94	1,905	F3SJ-B1905P25
98	1,985	F3SJ-B1985P25
102	2,065	F3SJ-B2065P25

^{*1} Protective height (mm) = Total sensor length

Accessories (sold separately)

Sensor mounting bracket

Appearance	Specifications	Application	Remarks	Order code
	Top/bottom bracket	Top/bottom bracket for F3SJ-E/B	2 for an emitter, 2 for a receiver, total of 4 per set	F39-LJB1
	Intermediate bracket	In combination use with top/bottom bracket for F3SJ-E/B Can be used as free-location bracket.	1 set with 2 pieces	F39-LJB2 ^{*1} ^{*2}
	Quick mount bracket	Quick mount bracket for F3SJ-E/B Supports M6 slide nut for aluminum frame.	1 set with 2 pieces	F39-LJB3-M6 ^{*1}
	Quick mount bracket	Quick mount bracket for F3SJ-E/B Supports M8 slide nut for aluminum frame.		F39-LJB3-M8 ^{*2}
	Quick mount M6 bracket	Bracket to mount an intermediate bracket to the aluminum frame with a single touch.	Hexagon socket head cap screws (M6 × 10) are included.	F39-LJB3-M6K ^{*1}
	Quick mount M8 bracket			Hexagon socket head cap screws (M8 × 14) are included.
	Compatible mounting bracket	Mounting bracket used when replacing existing area sensors (F3SJ-A or F3SN) with the F3SJ-E/B.	2 for an emitter, 2 for a receiver, total of 4 per set	F39-LJB4
	Contact mount bracket	Bracket to closely contact the back side of the sensor.	2 for an emitter, 2 for a receiver, total of 4 per set	F39-LJB5

^{*1} Combining F39-LJB2 and F39-LJB3-M6K makes F39-LJB3-M6.

^{*2} Combining F39-LJB2 and F39-LJB3-M8K makes F39-LJB3-M8.

Laser pointer

Appearance	Output	Order code
	Laser pointer for F3SJ	F39-PTJ

Specifications

Model		F3SJ-B P25
Sensor type		Type 4 safety light curtain
Setting tool connection*1		Parameter settings: Not available
Safety category		Safety purpose of category 4, 3, 2, 1, or B
Detection capability		Opaque objects 25 mm in diameter
Beam gap (P)		20 mm
Number of beams (n)		8 to 102
Protective height (PH)		185 to 2,065 mm
Lens diameter		Diameter 5 mm
Operating range*2		0.2 to 7 m
Response time (under stable light incident condition)	ON to OFF	15 ms max. (response time at 1 set connection, series connection of 2 sets or 3 sets)
	OFF to ON	70 ms max. (response time at 1 set connection, series connection of 2 sets or 3 sets)
Startup waiting time		2 s max.
Power supply voltage (Vs)		SELV/PELV 24 VDC±20% (ripple p-p 10% max.)
Consumption current (no load)		Emitter: Up to 22 beams: 52 mA max., 26 to 42 beams: 68 mA max., 46 to 62 beams: 75 mA max., 66 to 82 beams: 88 mA max., 86 to 102 beams: 101 mA max. Receiver: Up to 22 beams: 45 mA max., 26 to 42 beams: 50 mA max., 46 to 62 beams: 56 mA max., 66 to 82 beams: 61 mA max., 86 to 102 beams: 67 mA max.
Light source (emitted wavelength)		Infrared LED (870 nm)
Effective aperture angle (EAA)		Based on IEC 61496-2. Within ±2.5° for both emitter and receiver when the detection distance is 3 m or over
Safety outputs (OSSD)		Two PNP transistor outputs, load current 200 mA max., residual voltage 2 V max. (except for voltage drop due to cable extension), Leakage current 1 mA max., load inductance 2.2 H max.*3, Maximum capacity load 1 μF*4
Auxiliary output 1		One PNP transistor outputs, load current 100 mA max., residual voltage 2 V max. (except for voltage drop due to cable extension), leak current 1 mA max.
Output operation mode		Safety output: On when receiving light Auxiliary output: – Reverse output of safety output for a basic system – ON when muting/override for a muting system
Input voltage		ON voltage: Vs-3 V to Vs, OFF voltage: 0 V to 1/2 Vs or open*5
Mutual interference prevention function		Mutual interference prevention algorithm prevents interference in up to 3 sets.
Series connection		Time division emission by series connection Number of connections: up to 3 sets (between F3SJ-Bs only)Other models cannot be connected. Total number of beams: up to 192 beams Maximum cable length for 2 sets: no longer than 7 m
Test function		Self test (at power-ON and at power distribution) External test (emission stop function by test input)
Safety-related functions		Interlock (basic system) External device monitoring (basic system) Muting (muting system) Override (muting system)
Connection type		Connector method (M12, 8-pin)
Protection circuit		Output short-circuit protection, and power supply reverse polarity protection
Ambient temperature		Operating: -10 to 55°C (non-freezing), Storage: -25 to 70°C
Ambient humidity		Operating: 35% to 85% (no condensation), Storage: 35% to 95% RH
Operating ambient light intensity		Incandescent lamp: 3,000 lx max., Sunlight: 10,000 lx max.
Insulation resistance		20 MΩ min. (at 500 VDC)
Dielectric strength		1,000 VAC 50/60 Hz, 1 min
Degree of protection		IP65 (IEC 60529)
Vibration resistance		Malfunction: 10 to 55 Hz, Multiple amplitude of 0.7 mm, 20 sweeps in X, Y, and Z directions
Shock resistance		Malfunction: 100 m/s ² , 1,000 times each in X, Y, and Z directions
Pollution degree		Pollution degree 3 (IEC 60664-1)
Power cable		Connection method: Prewired connector cable, cable length 0.3 m, connector type (M12, 8-pin), connector: IP67 rated (when mated) Number of wires: 8 wires Cable diameter: Dia. 6 mm Allowable bending radius: R5 mm
Extension cable		30 m max.
Material		Case: Aluminum Cap: ABS resin, PBT Optical cover: PMMA resin (acrylic) Cable: Oil resistant PVC
Weight (packed state)		Weight (g) = (protective height) × 2.7 + 500
Accessories		Test rod, Instruction manual, User's manual (CD-ROM)*6
Applicable standards		IEC 61496-1, EN 61496-1 UL 61496-1, Type 4 ESPE (Electro-sensitive protective equipment) IEC 61496-2, CLC/TS 61496-2, UL 61496-2, Type 4 AOPD (Active opto-electronic protective devices) IEC 61508-1 to -3, EN 61508-1 to -3 SIL3 IEC 13849-1: 2006, EN ISO 13849-1: 2008 (PLe, Cat.4) UL 508, UL 1998, CAN/CSA C22.2 No.14, CAN/CSA C22.2 No.0.8

*1 Do not use the support software and setting console for F3SJ-A. Operation cannot be guaranteed.

*2 Use of the spatter protection cover causes a 10% maximum sensing distance attenuation.

*3 The load inductance is the maximum value when the safety output frequently repeats ON and OFF. When you use the safety output at 4 Hz or less, the usable load inductance becomes larger.

*4 These values must be taken into consideration when connecting elements including a capacitive load such as capacitor.

*5 The Vs indicates a voltage value in your environment.

*6 Mounting brackets are sold separately.

Connections

Basic Wiring Diagram

Wiring when using manual reset mode, external device monitoring (F3SJ-B P25) (PNP output)

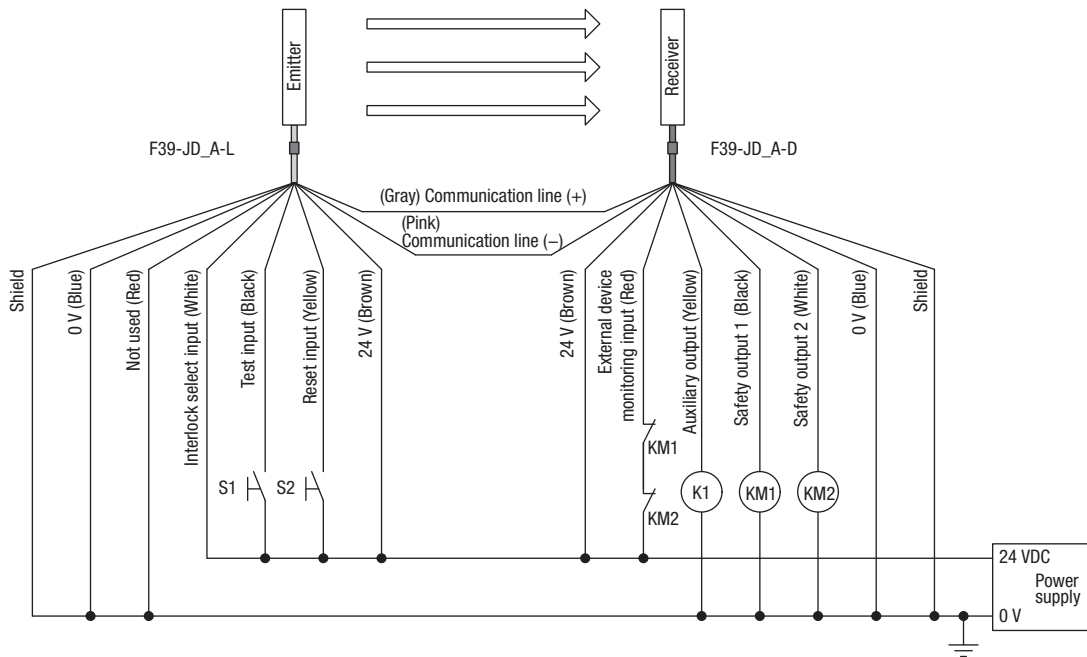

- S1 : External test switch (connect to 0 V if a switch is not required)
- S2 : Interlock/lockout reset switch
- KM1, KM2 : Safety relay with force-guided contact (G7SA) or magnetic contactor
- K1 : Load or PLC, etc. (for monitoring)



Advanced type for complex safety solutions

The F3SJ-A-family is a type 4 safety light curtain with a optical resolution of 14 mm and 30 mm. An operating range of up to 9 m and protective heights up to 2,495 mm are provided with no dead zone.

- Detection height = sensor height
- Muting and blanking function available
- Series connection up to 4 Sets
- LED bar for easy alignment and diagnosis
- Type 4 sensor complying with EN 61496-1 and up to PLe according EN ISO 13849-1

Ordering information

Application	Detection capability	Beam gap	Operating range	Protective height (mm)	Order code
Finger protection	Dia. 14 mm	9 mm	0.2 to 9 m	245 to 1,631	F3SJ-A____P14
Hand/arm protection	Dia. 30 mm	25 mm	0.2 to 9 m 0.2 to 7 m	245 to 1,620 1,745 to 2,495	F3SJ-A____P30

Safety light curtain model list

F3SJ-A14 series (9 mm gap), F3SJ-A14 TS series (9 mm gap)

Number of beams	Protective height (mm) ^{*1}	Order code
26	245	F3SJ-A0245P14
28	263	F3SJ-A0263P14
34	317	F3SJ-A0317P14
42	389	F3SJ-A0389P14
50	461	F3SJ-A0461P14
60	551	F3SJ-A0551P14
68	623	F3SJ-A0623P14
76	695	F3SJ-A0695P14
80	731	F3SJ-A0731P14
88	803	F3SJ-A0803P14
96	875	F3SJ-A0875P14
108	983	F3SJ-A0983P14
116	1,055	F3SJ-A1055P14
124	1,127	F3SJ-A1127P14
132	1,199	F3SJ-A1199P14
140	1,271	F3SJ-A1271P14

^{*1} Protective height (mm) = Total sensor length

F3SJ-A30 series (25 mm gap)

Number of beams	Protective height (mm) ^{*1}	Order code
10	245	F3SJ-A0245P30
12	295	F3SJ-A0295P30
16	395	F3SJ-A0395P30
19	470	F3SJ-A0470P30
21	520	F3SJ-A0520P30
22	545	F3SJ-A0545P30
23	570	F3SJ-A0570P30
25	620	F3SJ-A0620P30
29	720	F3SJ-A0720P30
32	795	F3SJ-A0795P30
35	870	F3SJ-A0870P30
37	920	F3SJ-A0920P30
38	945	F3SJ-A0945P30
41	1,020	F3SJ-A1020P30
44	1,095	F3SJ-A1095P30
45	1,120	F3SJ-A1120P30
48	1,195	F3SJ-A1195P30
51	1,270	F3SJ-A1270P30
56	1,395	F3SJ-A1395P30
65	1,620	F3SJ-A1620P30
70	1,745	F3SJ-A1745P30
75	1,870	F3SJ-A1870P30
80	1,995	F3SJ-A1995P30
90	2,245	F3SJ-A2245P30
95	2,370	F3SJ-A2370P30
100	2,495	F3SJ-A2495P30

^{*1} Protective height (mm) = Total sensor length

Accessories (sold separately)

Single-end connector cable (2 cables per set, for emitter and receiver)









For wiring with safety circuit such as single safety relay, safety relay unit, and safety controller.

Appearance	Cable length	Specifications	Order code
	0.5 m	M12 connector (8-pin)	F39-JCR5A
	3 m		F39-JC3A
	7 m		F39-JC7A
	10 m		F39-JC10A
	15 m		F39-JC15A
	20 m		F39-JC20A

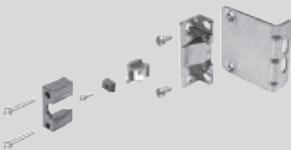
Setting Tools

Appearance	Type	Remarks	Order code
	"SD Manager" Setting support software for the F3SJ	Accessories: SD Manager CD-ROM (1), F39-CN1 branch connector (1), Connector cap (1), 2-m Dedicated cable (1), 0.3-m Dedicated cable with plug (1), Instruction manual	F39-GWUM

Sensor Mounting Brackets (Sold separately)

Appearance	Specifications	Application	Remarks	Order code
	Standard mounting bracket (for top/bottom)	(provided with the F3SJ)	2 for an emitter, 2 for a receiver, total of 4 per set	F39-LJ1
	Flat side mounting bracket	Use these small-sized brackets when performing side mounting with standard mounting brackets, so that they do not protrude from the detection surface.	2 for an emitter, 2 for a receiver, total of 4 per set	F39-LJ2
	Free-location mounting bracket (also used as standard inter- mediate bracket)	Use these brackets for mounting on any place without using standard bracket.	Two brackets per set	F39-LJ3
	F3SN Intermediate bracket Replacement spacers	When replacing the F3SN with the F3SJ, the mounting hole pitches in the Intermediate Brackets are not the same. This Spacer is placed between the mounting holes to mount the F3SJ.	1 set with 2 pieces	F39-LJ3-SN
	Top/bottom bracket B (mounting hole pitch 19 mm)	Mounting bracket used when replacing existing area sensors (other than F3SN or F3WN) with the F3SJ. For front mounting. Suitable for mounting hole pitch of 18 to 20 mm.	2 for an emitter, 2 for a receiver, total of 4 per set	F39-LJ4
	Bracket for replacing short-length F3SN	Mounting bracket used when an F3SN with protective height of 300 mm or less is replaced by an F3SJ.	2 for an emitter, 2 for a receiver, total of 4 per set	F39-LJ5
	Space-saving mounting bracket	Use these brackets to mount facing inward. Length is 12 mm shorter than the standard F39-LJ1 bracket.	2 for an emitter, 2 for a receiver, total of 4 per set	F39-LJ8
	Top/bottom bracket C (mounting hole pitch 13 mm)	Mounting bracket used when replacing existing area sensors having a mounting pitch of 13 mm with the F3SJ.	2 for an emitter, 2 for a receiver, total of 4 per set	F39-LJ11

Laser pointer

Appearance	Output	Order code
	Laser pointer for F3SJ	F39-PTJ

Specifications

F3SJ-A ___ P14/P30

Model	F3SJ-A ___ P14	F3SJ-A ___ P30
Sensor type	Type 4 safety light curtain	
Version	Ver. 2	
Setting tool connection	Connectable	
Safety category	Safety purpose of category 4, 3, 2, 1, or B	
Detection capability	Opaque objects 14 mm in diameter	Opaque objects 30 mm in diameter
Beam gap (P)	9 mm	25 mm
Number of beams (n)	26 to 180	10 to 100
Protective height (PH)	245 to 1,631 mm	245 to 2,495 mm
Lens diameter	Diameter 5 mm	
Operating range	0.2 to 9 m (protective height 1,640 mm max.), 0.2 to 7 m (protective height 1,655 mm min.) (Depending on the setting tool, the detection distance can be shortened to 0.5 m.)	
Response time (under stable light incident condition)	ON to OFF	1 set, 0245 to 983: 11 ms to 17.5 ms max. 1,055 or higher: 20 ms to 25 ms max.
	OFF to ON	1 set, 0245 to 983: 44 ms to 70 ms max. 1,055 or higher: 80 ms to 100 ms max.
Startup waiting time	2 s max. (2.2 s max. for series connection)	
Power supply voltage (Vs)	24 VDC±20% (ripple p-p10% max.)	
Current consumption (no load)	Emitter	To 50 beams: 76 mA max., 51 to 100 beams: 106 mA max., 101 to 150 beams: 130 mA max., 151 to 180 beams: 153 mA max., 201 to 234 beams: 165 mA max.
	Receiver	To 50 beams: 68 mA max., 51 to 100 beams: 90 mA max., 101 to 150 beams: 111 mA max., 151 to 180 beams: 128 mA max., 201 to 234 beams: 142 mA max.
Light source (emitted wavelength)	Infrared LED (870 nm)	
Effective aperture angle (EAA)	Based on IEC 61496-2. Within±2.5° for both emitter and receiver when the detection distance is 3 m or over	
Safety outputs (OSSD)	Two PNP transistor outputs, load current 300 mA max., residual voltage 2 V max. (except for voltage drop due to cable extension), allowable capacity load 2.2 μF, leak current 1 mA max. (This can be different from traditional logic (ON/OFF) because safety circuit is used.)	
Auxiliary output 1 (Non-safety output)	One PNP transistor output, load current 300 mA max., residual voltage 2 V max. (except for voltage drop due to cable extension), leak current 1 mA max.	
Auxiliary output 2 (Non-safety output. Function for Basic System.)	One PNP transistor output, load current 50 mA max., residual voltage 2 V max. (except for voltage drop due to cable extension), leak current 1 mA max.	
External indicator output (Non-safety output)	Available indicators Incandescent lamp: 24 VDC, 3 to 7 W LED lamp: Load current 10 mA to 300 mA max., leak current 1 mA max. (To use an external indicator, an F39-JJ3N universal indicator cable or an F39-A01P-PAC dedicated external indicator kit is required.)	
Output operation mode	Receiver	Safety output 1, 2: ON when receiving light Auxiliary output 1: Inverse of safety output signals (Operation mode can be changed with the setting tool.) External indicator output 1: Inverse of safety output signals for a basic system (Operation mode can be changed with the setting tool.), ON when muting/override for a muting system (Operation mode can be changed with the setting tool.)
	Emitter	Auxiliary output 2: Turns ON when the point of 30,000 operating hours is reached (Operation mode can be changed with the setting tool.) External indicator output 2: ON when lock-out for a basic system (Operation mode can be changed with the setting tool.) ON when muting/override for a muting system (Operation mode can be changed with the setting tool.)

Model	F3SJ-A P14	F3SJ-A P30
Input voltage	Test input, interlock selection input, reset input, and muting input are all ON voltage: 9 to 24 V (Vs) (sink current: 3 mA max.), OFF voltage: 0 to 1.5 V, or open External device monitoring input ON voltage: 9 to 24 V (Vs) (sink current: 5 mA max.), OFF voltage: 0 to 1.5 V, or open	
Indicator	Emitter	Light intensity level indicators (green LED × 2, orange LED × 3): ON based on the light intensity Error mode indicators (red LED × 3): Blink to indicate error details Power indicator (green LED × 1): ON while power is on Interlock indicator (yellow LED × 1): ON while under interlock, blinks at lockout. External device monitoring indicator (muting input 1 indicator), Blanking/test indicator (muting input 2 indicator) (green LED × 2): ON/flash according to function
	Receiver	Light intensity level indicators (green LED × 2, orange LED × 3): ON based on the light intensity Error mode indicators (red LED × 3): Blink to indicate error details OFF output indicator (red LED × 1): ON when safety output is OFF, blinks at lockout. ON output indicator (green LED × 1): ON while safety output is ON Muting error indicator, Blanking/test indicator (green LED × 2): ON/flash according to function
Mutual interference prevention function	Interference light prevention algorithm, sensing distance change function	
Series connection	Time division emission by series connection Number of connections: up to 4 sets (F3SJ-A only) F3SJ-E, F3SJ-B and F3SJ-TS cannot be connected. Total number of beams: up to 400 beams Maximum cable length for 2 sets: no longer than 15 m	
Test function	Self test (at power-ON and at power distribution) External test (emission stop function by test input)	
Safety-related functions	Start interlock, restart interlock (Must be set with a setting tool when the muting function is used.) External device monitor Muting (Lamp burnout detection, override function included. F39-CN6 key cap for muting is required.) Fixed blanking (must be set by a setting tool) Floating blanking (must be set by a setting tool)	
Connection method	Connector method (M12, 8-pin)	
Protection circuit	Output short-circuit protection, and power supply reverse polarity protection	
Ambient temperature	Operating: -10 to 55°C (no icing), Storage: -30 to 70°C	
Ambient humidity	Operating: 35% to 85% (no condensation), Storage: 35% to 95%	
Operating ambient light intensity	Incandescent lamp: receiving-surface light intensity of 3,000 lx max., Sunlight: receiving-surface light intensity of 10,000 lx max.	
Insulation resistance	20 MΩ min. (at 500 VDC)	
Withstand voltage	1,000 VAC 50/60 Hz, 1 min	
Degree of protection	IP65 (IEC 60529)	
Vibration resistance	Malfunction: 10 to 55 Hz, Multiple amplitude of 0.7 mm, 20 sweeps in X, Y, and Z directions	
Shock resistance	Malfunction: 100 m/s ² , 1,000 times each in X, Y, and Z directions	
Material	Casing (including metal parts on both ends): Aluminum, zinc die-cast Cap: ABS resin, Optical cover: PMMA resin (acrylic), Cable: Oil resistant PVC	
Weight (packaged)	Calculate using the following expressions: (1) For F3SJ-A ___14, weight (g) = (protective height) × 1.7 + α (2) F3SJ-A ___30, weight (g) = (protective height) × 1.5 + α The values for α are as follows: Protected height 245 to 596 mm: = 1,100 protected height 1,660 to 2,180 mm: = 2,400 Protected height 600 to 1,130 mm: = 1,500 protected height 2,195 to 2,500 mm: = 2,600 Protected height 1,136 to 1,658 mm: = 2,000	
Accessories	Test rod (*1), instruction manual, standard mounting bracket (F39-LJ1 bracket for top/bottom mounting), mounting brackets (intermediate) (*2), error mode label, User's Manual (CD-ROM) *1. The F3SJ-A□□□□55 is not included. *2. Number of intermediate brackets depends on protective height of F3SJ. For protective height from 600 to 1,130 mm: 1 set for each of the emitter and receiver is included For protective height from 1,136 to 1,658 mm: 2 sets for each of the emitter and receiver are included For protective height from 1,660 to 2,180 mm: 3 sets for each of the emitter and receiver are included For protective height from 2,195 to 2,500 mm: 4 sets for each of the emitter and receiver are included	
Applicable standards	IEC 61496-1, EN 61496-1 UL 61496-1, Type 4 ESPE (Electro-Sensitive Protective Equipment) IEC 61496-2, CLC/TS 61496-2, UL 61496-2, Type 4 AOPD (Active Opto-electronic Protective Devices) IEC 61508-1 to -3, EN 61508-1 to -3 SIL3 IEC 13849-1: 2006, EN ISO 13849-1: 2008 (PLe, Cat.4) UL 508, UL 1998, CAN/CSA C22.2 No.14, CAN/CSA C22.2 No.0.8	

Response Time

Model	Protected height (mm)	Number of beams	Response time ms (ON to OFF)	Response time ms (OFF to ON)
F3SJ-A____14 Series	245 to 263	26 to 28	11	44
	281 to 389	30 to 42	12	48
	407 to 497	44 to 54	13	52
	515 to 605	56 to 66	14	56
	623 to 731	68 to 80	15	60
	767 to 983	84 to 108	17.5	70
	1,055 to 1,271	116 to 140	20	80
	1,343 to 1,559	148 to 172	22.5	90
F3SJ-A____30 Series	1,631	180	25	100
	245 to 395	10 to 16	10	40
	420 to 720	17 to 29	11	44
	745 to 1,045	30 to 42	12	48
	1,070 to 1,295	43 to 52	13	52
	1,395 to 1,620	56 to 65	14	56
	1,745 to 1,995	70 to 80	15	60
	2,120 to 2,495	85 to 100	17.5	70

Note: Use the following expressions for series connection.

- For 2-set series connection:
Response time (ON to OFF): Response time of the 1st unit + Response time of the 2nd unit – 1 (ms), Response time (OFF to ON): Response time calculated by the above × 4 (ms)
- For 3-set series connection:
Response time (ON to OFF):
Response time of the 1st unit + Response time of the 2nd unit + Response time of 3rd unit – 5 (ms), Response time (OFF to ON): Response time calculated by the above × 5 (ms)
For models with the “-TS” suffix, multiply the response time obtained by the above × 5 (ms), or use 200 ms, whichever is less.)
- For 4-set series connection:
Response time (ON to OFF): Response time of the 1st unit + Response time of the 2nd unit + Response time of the 3rd unit + Response time of the 4th unit – 8 (ms)
Response time (OFF to ON): Response time calculated by the above × 5 (ms)

Cable extension length

Total cable extension length must be no greater than the lengths described below.

When the F3SJ and an external power supply are directly connected, or when the F3SJ is connected to a G9SA-300-SC.

Condition	1 set	2 sets	3 sets	4 sets
Using incandescent lamp for auxiliary output and external indicator output	45 m	40 m	30 m	20 m
Not using incandescent lamp	100 m	60 m	45 m	30 m

When connected to the F3SP-B1P

Condition	1 set	2 sets	3 sets	4 sets
Using incandescent lamp for external indicator output 2	40 m	30 m	25 m	20 m
Using incandescent lamp for external indicator output 1	60 m	45 m	30 m	20 m
Using incandescent lamp for auxiliary output 1				
Not using incandescent lamp	100 m	60 m	45 m	30 m

Note: Keep the cable length within the rated length. Failure to do so is dangerous as it may prevent safety functions from operating normally.

Connections

Basic Wiring Diagram

PNP Output

Wiring when using manual reset mode, external device monitoring.

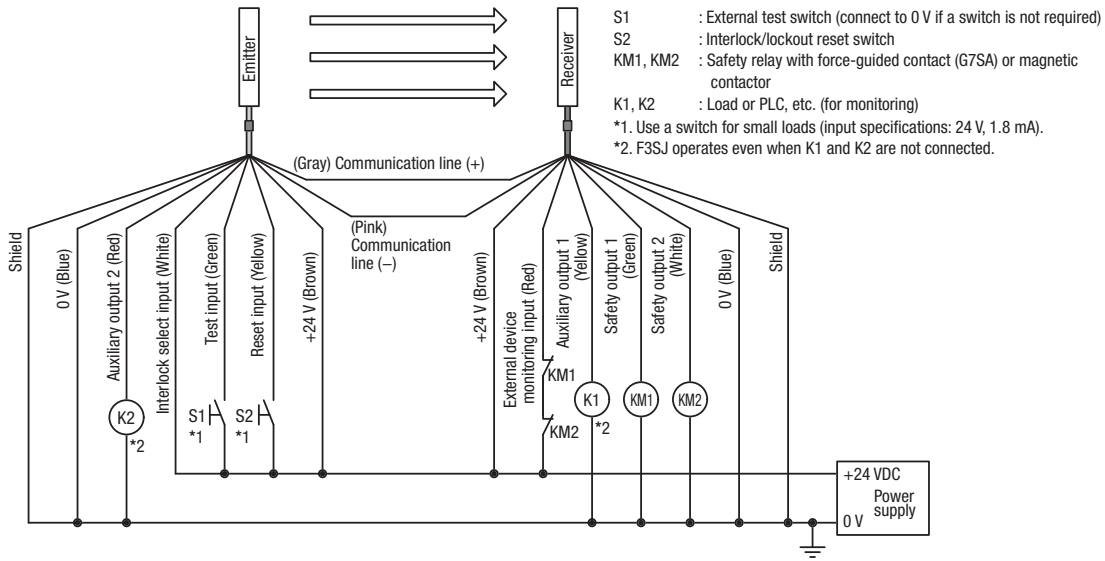



Category 4 / 2 safety light curtain

The MS4800 and MS2800 family of safety light curtain provides simplicity in mounting, configuring, daily use and maintenance by providing a:

- Sensing distance up to 20m for 30mm resolution and 7 m for 14mm resolution
- LED bar for easy alignment and diagnosis
- DIP-switch setup for blanking, muting and optical coding
- Category 4 / 2 sensor complying with EN 61496-1
- All-in-one M12 connection and mounting concept with robust housing
- Multicascadable up to 3 sets

Ordering information

MS2800 Safety Category 2

Connection features	Standard				Master				Slave			
Standard Standalone operation												
Master Series connection, muting												
Slave Series connection only												
	MS2800S-				MS2800FS-				MS2800F-			
Function Set	Basic				Advanced				Basic		Advanced	
Basic Interlock, restart, EDM, 2 optical channels, integrated alignment tool												
Advanced Muting, blanking (fixed/floating)												
	MS2800S-EB-		MS2800S-EA-		MS2800FS-EB-		MS2800FS-EA-		MS2800F-E-			
Resolution	14 mm		30 mm		14 mm		30 mm		14 mm		30 mm	
14 mm finger protection	MS2800S-EB-014-		MS2800S-EB-030-		MS2800FS-EB-014-		MS2800FS-EB-030-		MS2800F-E-014-		MS2800F-E-030-	
30 mm hand protection	MS2800S-EB-014-		MS2800S-EB-030-		MS2800FS-EB-014-		MS2800FS-EB-030-		MS2800F-E-014-		MS2800F-E-030-	
Length	240 ... 1800		280 ... 2120		280 ... 1800		280 ... 2120		240 ... 1280		280 ... 2120	
40 mm increments	280 ... 1800		280 ... 2120		280 ... 1800		280 ... 2120		240 ... 1280		280 ... 2120	

MS4800 Safety Category 4

Connection features	Standard				Master				Slave			
Standard Standalone operation												
Master Series connection, muting												
Slave Series connection only												
	MS4800S-				MS4800FS-				MS4800F-			
Function Set	Basic				Advanced				Basic		Advanced	
Basic Interlock, restart, EDM, 2 optical channels, integrated alignment tool												
Advanced Muting, blanking (fixed/floating)												
	MS4800S-EB-		MS4800S-EA-		MS4800FS-EB-		MS4800FS-EA-		MS4800F-E-			
Resolution	14mm		30mm		14mm		30mm		14mm		30mm	
14mm finger protection	MS4800S-EB-014-		MS4800S-EB-030-		MS4800FS-EB-014-		MS4800FS-EB-030-		MS4800F-E-014-		MS4800F-E-030-	
30mm hand protection	MS4800S-EB-014-		MS4800S-EB-030-		MS4800FS-EB-014-		MS4800FS-EB-030-		MS4800F-E-014-		MS4800F-E-030-	
Length	240mm ... 1800		280 ... 2120		280 ... 1800		280 ... 2120		240 ... 1280		280 ... 2120	
40mm increments	280 ... 1800		280 ... 2120		280 ... 1800		280 ... 2120		240 ... 1280		280 ... 2120	

Examples

MS2800S-EB-030-1000
 Standalone operation
 Basic function set
 30mm resolution
 1000mm protective height

MS4800FS-EA-014-1200
 Series connection model
 Advanced function set
 14mm resolution
 1200mm protective height

MS4800F-E-014-600
 Slave operation
 14mm resolution
 600mm protective height

Specifications

Model	MS4800 -E - - - - -	MS2800 -E - - - - -
Sensor type	Type 4	Type2
Normal operating range	14 mm resolution: 0.3 - 7 m, 30 mm resolution: 0.3 - 20 m	
Reduced range (DIP-switch 6)	14 mm resolution: 0.3 - 3 m, 30 mm resolution: 0.3 - 8 m	
Beam pitch	14 mm resolution: 10 mm; 30 mm resolution: 20 mm	
Protective height	14 mm resolution: 280 - 1800 mm; 30 mm resolution: 240 - 2120 mm	
Detection capability	14 mm resolution: 14 mm non-transparent; 30 mm resolution: 30 mm non-transparent	
Effective aperture angle (EAA)	Within $\pm 2,5^\circ$	Within $\pm 5,0^\circ$
	for the emitter and receiver at a detection distance of at least 3m according to IEC61496-2	
Light source	Infrared LED's (880 nm), Power dissipation: 180 mW, Class 1 per EN60825-1	
Supply voltage (Vs)	24 VDC $\pm 20\%$, according EN/IEC60204, able to cover a drop of voltage of at least 20 msec	
OSSD	Two safety related PNP transistor output, load current 625 mA max. ^{*1} , short circuit protection	
Auxiliary output (non safety output)	One PNP output sourcing 100mA @ 24VDC. This output follows the OSSD's	
Output operation mode	OSSD output: Light-ON	
Test functions	Self-test (after power ON and during operation)	
Safety-related functions	All versions: Auto reset/interlock with manual reset, EDM (external device monitoring) advanced versions only: fixed blanking, floating blanking, muting	
Response time	ON to OFF: 14 to 59 ms	
Ambient light intensity	Incandescent lamp: 3000 lx max. (light intensity on the receiver surface)	
Ambient temperature	Operating: -10°C to +55°C, storage: -25°C to +70°C (without icing or condensation)	
Degree of protection	IP65 (IEC60529)	
Connection methode	Flexible cable with M 12 connection: receiver: 8 pins, transmitter: 5 pins	
Materials	Case: Polyurethane powder painted aluminium, cap: polycarbonate, front window: acrylic, mounting brackets: cold rolled steel	
Size (cross section)	39 x 50 mm	
Receiver indicator lights	Individual Beam Indicator (IBI), interlock, blanking activ, RUN and STOP state, error codes	
Transmitter indicator lights	ON, OFF, failure	
AOPD (ESPE)	Type4 acc. IEC 61496-1	Type2 acc. IEC 61496-1
Suitable for safety control systems	Cat. 4 acc. EN954-1, PLe acc. EN ISO 13849-1	Cat. 2 acc. EN954-1, PLC acc. EN ISO 13849-1
Safety Integrity Level	SIL 3 according IEC 61508	
PFH	$5,9 \times 10^{-8}$	

*1 Up to 12 m we recommend to use the F39-JMR cables, to use longer cables and a current of 625 mA the F39-JMR cables are necessary.

Connection example

Using a manual restart and an external device monitoring

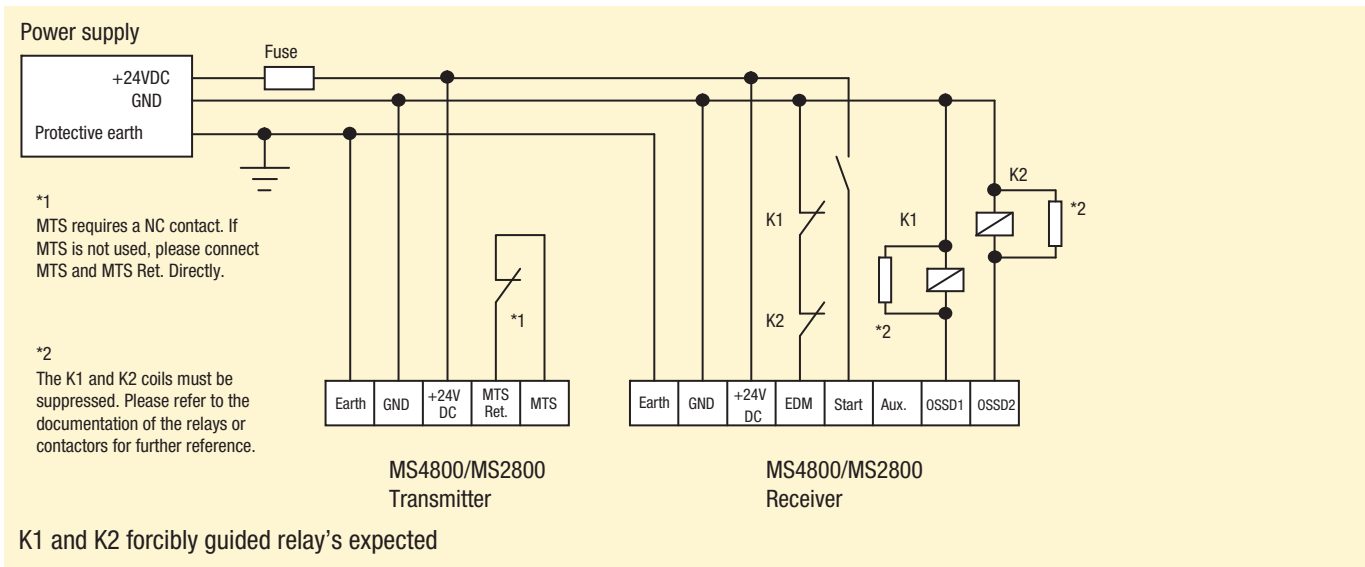



Multi-beam, finger- and hand protection safety sensor

The F3S-TGR-CL multi-beam, finger- and hand protection safety sensors satisfying with integrated safety control functions selectable via built-in dip-switches.

- Type 2 or type 4 acc. EN61496-1
- PL c or PL e acc. ISO13849
- Family concept in wiring and mounting
- All models with dip-switch setup for external device monitoring, interlock function, range setting (short and long range) and optical or wired coding
- Advanced models with pre-reset function, T-, L- or X- muting function and muting lamp integrated

Ordering information

Multi-beam safety sensors

F3S-TGR-CL2_-K_ (Type 2)

System	Sensing distance	Detection capability	Order code	
			Basic feature set ^{*1}	Advanced feature set ^{*2}
Active/passive	0.5 m to 12 m	500	F3S-TGR-CL2B-K2C-500	F3S-TGR-CL2A-K2C-500
	0.5 m to 8 m	400	F3S-TGR-CL2B-K3C-800	F3S-TGR-CL2A-K3C-800
	0.5 m to 7 m	300	F3S-TGR-CL2B-K4C-900	F3S-TGR-CL2A-K4C-900
		400	F3S-TGR-CL2B-K4C-1200	F3S-TGR-CL2A-K4C-1200
Active/active	0.5 m to 40 m	500	F3S-TGR-CL2B-K2-500	F3S-TGR-CL2A-K2-500
		400	F3S-TGR-CL2B-K3-800	F3S-TGR-CL2A-K3-800
		300	F3S-TGR-CL2B-K4-900	F3S-TGR-CL2A-K4-900
		400	F3S-TGR-CL2B-K4-1200	F3S-TGR-CL2A-K4-1200
Active/active, long distance	25 m to 50 m	500	F3S-TGR-CL2B-K2-500-LD	F3S-TGR-CL2A-K2-500-LD
		400	F3S-TGR-CL2B-K3-800-LD	F3S-TGR-CL2A-K3-800-LD
		300	F3S-TGR-CL2B-K4-900-LD	F3S-TGR-CL2A-K4-900-LD
		400	F3S-TGR-CL2B-K4-1200-LD	F3S-TGR-CL2A-K4-1200-LD

F3S-TGR-CL4_-K_ (Type 4)

System	Sensing distance	Detection capability	Order code	
			Basic feature set ^{*1}	Advanced feature set ^{*2}
Active/passive	0.5 m to 12 m	500	F3S-TGR-CL4B-K2C-500	F3S-TGR-CL4A-K2C-500
	0.5 m to 8 m	400	F3S-TGR-CL4B-K3C-800	F3S-TGR-CL4A-K3C-800
	0.5 m to 7 m	300	F3S-TGR-CL4B-K4C-900	F3S-TGR-CL4A-K4C-900
		400	F3S-TGR-CL4B-K4C-1200	F3S-TGR-CL4A-K4C-1200
Active/active	0.5 m to 40 m	500	F3S-TGR-CL4B-K2-500	F3S-TGR-CL4A-K2-500
		400	F3S-TGR-CL4B-K3-800	F3S-TGR-CL4A-K3-800
		300	F3S-TGR-CL4B-K4-900	F3S-TGR-CL4A-K4-900
		400	F3S-TGR-CL4B-K4-1200	F3S-TGR-CL4A-K4-1200
Active/active, long distance	25 m to 50 m	500	F3S-TGR-CL4B-K2-500-LD	F3S-TGR-CL4A-K2-500-LD
		400	F3S-TGR-CL4B-K3-800-LD	F3S-TGR-CL4A-K3-800-LD
		300	F3S-TGR-CL4B-K4-900-LD	F3S-TGR-CL4A-K4-900-LD
		400	F3S-TGR-CL4B-K4-1200-LD	F3S-TGR-CL4A-K4-1200-LD

^{*1} Basic feature set: Manual/automatic restart, coding

^{*2} Advanced feature set: Basic + Muting + integrated Muting lamp + Pre-reset

Safety sensors

F3S-TGR-CL2_ (Type 2)

Feature set	Master/Slave	Sensing distance	Detection capability	Length	Order code
Basic* ¹	Standalone	0.2 m to 6 m	14 mm	150 mm to 2,400 mm* ³	F3S-TGR-CL2B-014- _
		0.2 m to 14 m	35 mm		F3S-TGR-CL2B-035- _
Advanced* ²	Standalone	0.2 m to 6 m	14 mm		F3S-TGR-CL2A-014- _
		0.2 m to 14 m	35 mm		F3S-TGR-CL2A-035- _
	Master	0.2 m to 6 m	14 mm		F3S-TGR-CL2A-014- _M
		0.2 m to 14 m	35 mm		F3S-TGR-CL2A-035- _M
	Slave	0.2 m to 6 m	14 mm		F3S-TGR-CL2A-014- _S
		0.2 m to 14 m	35 mm		F3S-TGR-CL2A-035- _S
		70 mm	300 mm to 2,100 mm		F3S-TGR-CL2A-070- _S

F3S-TGR-CL4_ (Type 4)

Feature set	Master/Slave	Sensing distance	Detection capability	Length	Order code
Basic* ¹	Standalone	0.2 m to 6 m	14 mm	150 mm to 2,400 mm* ³	F3S-TGR-CL4B-014- _
		0.2 m to 14 m	35 mm		F3S-TGR-CL4B-035- _
Advanced* ²	Standalone	0.2 m to 6 m	14 mm		F3S-TGR-CL4A-014- _
		0.2 m to 14 m	35 mm		F3S-TGR-CL4A-035- _
	Master* ⁴	0.2 m to 6 m	14 mm		F3S-TGR-CL4A-014- _M
		0.2 m to 14 m	35 mm		F3S-TGR-CL4A-035- _M
	Slave* ⁴	0.2 m to 6 m	14 mm		F3S-TGR-CL4A-014- _S
		0.2 m to 14 m	35 mm		F3S-TGR-CL4A-035- _S
		70 mm	300 mm to 2,100 mm		F3S-TGR-CL4A-070- _S

*¹ Basic feature set: Manual/automatic restart, coding

*² Advanced feature set: Basic + Muting + integrated Muting lamp + Pre-reset

*³ Available length (in mm): 150, 300, 450, 600, 750, 900, 1,050, 1,200, 1,350, 1,500, 1,650, 1,800, 1,950, 2,100, 2,250, (2,400 mm, only standalone versions)

*⁴ Master/slave system: A master/slave system cannot exceed the total length of 2,400 mm

F3S-TGR-CL- _ _ M/S Master-Slave Series

- A Master-Slave cascade system is made of one master segment and one slave segment.
- The length of the total protective field can vary from minimum 300 mm till maximum 2,400 mm.

- The interconnect cable length limitation between master and slave segment is in total max. 0,9 m.

Possible combinations of master and slave are in this table:

		Slave models																					
		14 mm or 35 mm resolution															70 mm resolution						
		150	300	450	600	750	900	1,050	1,200	1,350	1,500	1,650	1,800	1,950	2,150	2,250	300	600	900	1,200	1,500	1,800	2,100
Master models (14 mm or 35 mm resolution)	150	OK	OK	OK	OK	OK	OK	OK	OK	OK	OK	OK	OK	OK	OK		OK	OK	OK	OK	OK	OK	OK
	300	OK	OK	OK	OK	OK	OK	OK	OK	OK	OK	OK	OK	OK	OK		OK	OK	OK	OK	OK	OK	OK
	450	OK	OK	OK	OK	OK	OK	OK	OK	OK	OK	OK	OK	OK			OK	OK	OK	OK	OK	OK	
	600	OK	OK	OK	OK	OK	OK	OK	OK	OK	OK	OK	OK				OK	OK	OK	OK	OK	OK	
	750	OK	OK	OK	OK	OK	OK	OK	OK	OK	OK	OK					OK	OK	OK	OK	OK		
	900	OK	OK	OK	OK	OK	OK	OK	OK	OK	OK						OK	OK	OK	OK	OK		
	1,050	OK	OK	OK	OK	OK	OK	OK	OK	OK							OK	OK	OK	OK			
	1,200	OK	OK	OK	OK	OK	OK	OK	OK	OK							OK	OK	OK	OK			
	1,350	OK	OK	OK	OK	OK	OK	OK	OK								OK	OK	OK				
	1,500	OK	OK	OK	OK	OK	OK										OK	OK	OK				
	1,650	OK	OK	OK	OK	OK											OK	OK					
	1,800	OK	OK	OK	OK												OK	OK					
	1,950	OK	OK	OK													OK						
2,100	OK	OK														OK							
2,250	OK																						

Accessories

Receiver cables (M12-8pin, shielded, flying leads)

Shape	Description	Remark	Order code
	Sensor connector with open cable end M12-8pin, outer shielding layer	Receiver cable, 2 m length	Y92E-M12PURSH8S2M-L
		Receiver cable, 5 m length	Y92E-M12PURSH8S5M-L
		Receiver cable, 10 m length	Y92E-M12PURSH8S10M-L
		Receiver cable, 25 m length	Y92E-M12PURSH8S25M-L

Transmitter cables (M12-4pin, shielded, flying leads)

Shape	Description	Remark	Order code
	Sensor connector with open cable end M12-4pin, outer shielding layer	Transmitter cable, 2 m length	Y92E-M12PURSH4S2M-L
		Transmitter cable, 5 m length	Y92E-M12PURSH4S5M-L
		Transmitter cable, 10 m length	Y92E-M12PURSH4S10M-L
		Transmitter cable, 25 m length	Y92E-M12PURSH4S25M-L

Mounting brackets

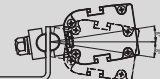
Shape	Description	Remark	Order code
	Mounting bracket	Mounting bracket × 1, SLC mounting screws × 1 set	F39-TGR-SB-ST ^{*1}
	Adjustable bracket	Adjustable bracket × 1, Bracket mounting screws × 1 set	F39-TGR-ADJ

^{*1} Brackets amount included in shipment is shown in table of Dimensions

Master-Slave accessories

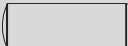
Shape	Description	Remark	Order code
	Male-male extension connector M12-8pin, outer shielding layer	Connection cable, 0.3 m length	Y92E-M12MSM12MSPURSH80.3M-L
		Connection cable, 0.9 m length	Y92E-M12MSM12MSPURSH80.9M-L (included in slave system)
	Alignment kit – end cap	To support alignment of a Master-Slave system	F39-TGR-CL-MSA (included in slave system)

Laser alignment kit

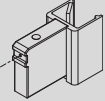
Shape	Description	Remark	Order code
	Laser alignment kit	Scanning range: ≤ 60 m Batteries: 2 × 1.5 V Micro/AAA Laser Class 2 (IEC 60825)	F39-TGR-CL-LLK

Specifications

Multi-beam safety sensors

Item	F3S-TGR-CL2_-0_	F3S-TGR-CL4_-0_
Sensor type	Type 2	Type 4
Protective height	500 mm, 800 mm, 900 mm or 1,200 mm	
Operating range	F3S-TGR-CL__-K_ 0.5 to 20 m or 20 to 40 m (Dip switch option) F3S-TGR-CL__-K_-LD 25 to 50 m F3S-TGR-CL__-K2C-500 0.5 to 12 m F3S-TGR-CL__-K3C-800 0.5 to 8 m F3S-TGR-CL__-K4C- 0.5 to 7 m	
Beam pitch	F3S-TGR-CL__-K2_-500: 2 beams, 500 mm F3S-TGR-CL__-K3_-800: 3 beams, 400 mm F3S-TGR-CL__-K4_-900: 4 beams, 300 mm F3S-TGR-CL__-K4_-1200: 4 beams, 400 mm	
Effective aperture angle (EAA)	Within $\pm 5^\circ$	Within $\pm 2.5^\circ$
	for the emitter and receiver at a detection distance of at least 3 m according to IEC 61496-2	
Light source	Infrared LED (880 nm), power dissipation <3 mW, Class 1 per EN 60825-1	
Supply voltage	24 VDC \pm 20%, according EN 60204-1 able to cover a drop of voltage of at least 20 ms	
OSSD	2 PNP transistor outputs, load current 2 \times 250 mA max	
Test functions	Self test (after power ON and during operation)	
Safety-related functions	All models with dip-switch setup for external device monitoring, interlock function, range setting (short and long range) and optical or wired sync. Advanced models with selectable pre-reset function, T-, L-or X- muting function (timeout or infinite muting dip switch option) and muting lamp integrated (only for the non master-slave systems)	
Response time	ON to OFF: Maximum: 13 ms	
Ambient temperature	Operating: -10 to 55°C, Storage: -25 to 70°C (no icing, no condensation)	
Ambient humidity	95% not condensing	
Degree of protection	IP 65 (IEC 60529)	
Materials	Housing: Painted aluminum, Yellow, RAL 1018 Front Window: Acrylic Lexan Red end cap: PA6 (Standalone models), Transparent end cap: PC (Advanced standalone models), Sealing Gasket: EPDM Mounting Bracket: Cold rolled Steel	
Suitable for safety control systems	PLc (ISO 13849-1)	PLe (ISO 13849-1)
Category	Categorie 2	Categorie 4
PFHd	2.5×10^{-9}	
Proof test interval	every 20 years	

Finger- and hand safety protection sensors

Item	F3S-TGR-CL2_-0_	F3S-TGR-CL4_-0_
Sensor type	Type 2	Type 4
Protective height	150 mm to 2,400 mm	
Operating range (short setting or long setting)	F3S-TGR-CL__-014: 0.2 m to 3 m or 3 m to 6 m (Dip switch option) F3S-TGR-CL__-035: 0.2 m to 7 m or 7 m to 14 m (Dip switch option) F3S-TGR-CL__-070: 0.2 m to 7 m or 7 m to 14 m (Dip switch option)	
Detection capability	F3S-TGR-CL__-014: Opaque objects 14 mm in diameter F3S-TGR-CL__-035: Opaque objects 35 mm in diameter F3S-TGR-CL__-070: Opaque objects 70 mm in diameter	
Effective aperture angle (EAA)	Within $\pm 5^\circ$	Within $\pm 2.5^\circ$
	for the emitter and receiver at a detection distance of at least 3 m according to IEC 61496-2	
Light source	Infrared LED (880 nm), power dissipation <3 mW, Class 1 per EN 60825-1	
Supply voltage	24 VDC \pm 20%, according EN 60204-1 able to cover a drop of voltage of at least 20 ms	
OSSD	2 PNP transistor outputs, load current 2 \times 250 mA max	
Series connection	Number of connections: One master and one slave safety light curtain Total number of beams \leq 336 Maximum interconnect cable length: 900 mm	
Test functions	Self test (after power ON and during operation)	
Safety-related functions	All models with dip-switch setup for external device monitoring, interlock function, range setting (short and long range) and optical or wired sync. Advanced models with selectable pre-reset function, T-, L-or X- muting function (timeout muting), blanking, single / double brake function and muting lamp integrated (only for the non master-slave systems)	
Response time	ON to OFF: 14 ms to 103 ms	
Ambient temperature	Operating: -10 to 55°C, Storage: -25 to 70°C (no icing, no condensation)	
Ambient humidity	95% not condensing	
Degree of protection	IP 65 (IEC 60529)	
Materials	Housing: Painted aluminum, Yellow, RAL 1018 Front Window: Acrylic Lexan Red end cap: PA6 (Standalone models), Transparent end cap: PC (Advanced standalone models), Die cast aluminium (Master-, Slave models) Sealing Gasket: EPDM Mounting Bracket: Cold rolled Steel	
Suitable for safety control systems	PLc (ISO 13849-1)	PLe (ISO 13849-1)
Category	Categorie 2	Categorie 4
PFHd	2.5×10^{-9}	
Proof test interval	every 20 years	

F3S-TGR-CL and GSB-301-D in manual reset

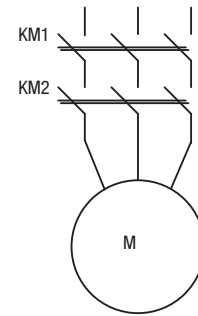
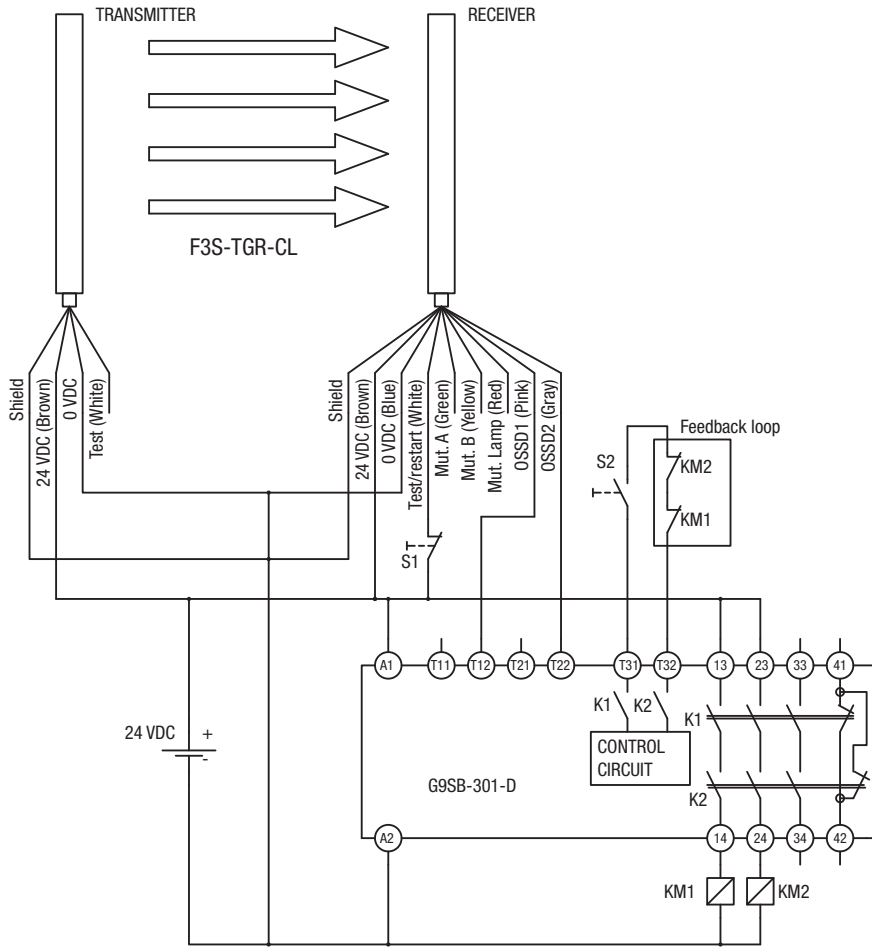

Note: This circuit achieves up to PLe according to EN ISO 13849-1 with F3S-TGR-CL4 and up to PLc according to EN ISO 13849-1 with F3S-TGR-CL2.



Adjustable stands family

F39-TGR-AS adjustable stands product family is used to easily install, align and protect multi-beam safety sensors in the F3S-TGR-CL range. Optional mirror kits support perimeter guarding. Adjustable muting sensor mounting systems support L-, T- and X-muting.

- Robust adjustable stands in 1,200 mm and 1,600 mm
- Muting accessories for T-, X- and L-muting
- Mirror system for 2-, 3- and 4-beam applications
- Simple installation of the safety sensors
- Easy alignment of the stand by integrated level on top
- Integrated cable support plus optional cable cover

Ordering information

Adjustable stands

		Order code
Adjustable stand, 1,200 mm high	Safety sensors, Mirror systems	F39-TGR-AS-B1200
Adjustable stand, 1,600 mm high	Safety sensors, Mirror systems, Muting applications	F39-TGR-AS-B1600

Mirror system for multi-beam safety sensors (F3S-TGR-CL_-K_)

		Order code
Mirror mounting plate	2-, 3- and 4-beam systems ≤900 mm	F39-TGR-AS-MM1
	4-beam system 1,200 mm	F39-TGR-AS-MM2
Adjustable mirror kit	Use 1 pcs F39-TGR-AS-AM1 for each beam of the safety sensor	F39-TGR-AS-AM1

Muting accessories

		Order code
Mounting system for muting sensors	For L-muting	F39-TGR-AS-MA-MBL
	For X- and T-muting	F39-TGR-AS-MA-MBXT
Mounting bracket for muting sensors	For OMRON E3Z and E3G-family	F39-TGR-AS-MA-MSM
Mounting bracket for reflectors	For OMRON E39-R1S	F39-TGR-AS-MA-MRM

Cable cover

		Order code
Cable cover	For 1,200 mm stand	F39-TGR-AS-MA-CC12
	For 1,600 mm stand	F39-TGR-AS-MA-CC16

Specifications

Housing	Painted steel	
Ambient temperature	During operation; -25 to 80°C (with no dew condensation)	
Adjustment range	Rotation	±15°
	vertical	F3S-TGR-CL-Sensor can be adjusted ±100 mm
	horizontal	±10°

Configuration examples

3-sided guarding, 2-beam system

e.g. F3S-TGR-CL4B-K2-500

- 1) Adjustable stand F39-TGR-AS-B1200 (4 x)
- 2) Mirror mounting plate F39-TGR-AS-MM1 (2 x)
- 3) Mirror kit F39-TGR-AS-AM1 (4 x)

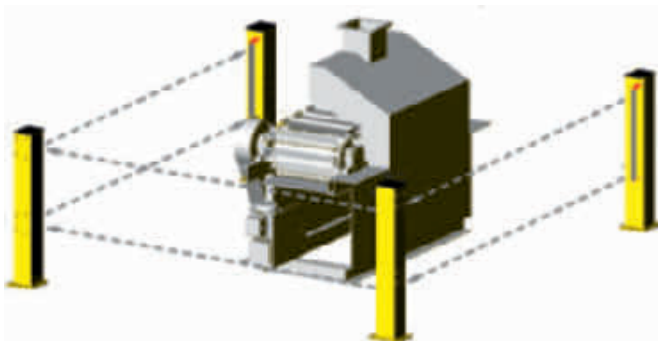

Muting system, X-muting, active/passive setup

e.g. F3S-TGR-CL4A-K2C-500

- 1) Adjustable stand F39-TGR-AS-B1600 (2 x)
- 2) Muting mounting system F39-TGR-AS-MA-MBXT (2 x)
- 3) Mounting bracket (sensor) F39-TGR-AS-MSM
- 4) Mounting bracket (reflector) F39-TGR-AS-MRM





Muting actuators

The F39-TGR-MCL- _ muting actuators are plug-and-play accessories for the F3S-TGR-CL Safety Sensors. Easy wiring of the entire muting system is provided by connection boxes managing all connections needed.

- Active/active and active/passive systems supported
- T- and L- shape muting by using same parts
- Selectable muting sensor sequence
- Pre-installed mounting brackets
- Pre-wired connection cables
- Supporting Type 2 and Type 4 applications

Ordering information

Muting actuators (mounting brackets are included)

		Order code
Transmitter + Receiver set	active/active	F39-TGR-MCL
Receiver only	active/active	F39-TGR-MCL-D
Transmitter only	active/active	F39-TGR-MCL-L
Transceiver + Reflector set	active/passive	F39-TGR-MCL-R
Transceiver only	active/passive	F39-TGR-MCL-R-A
Reflector only	active/passive	F39-TGR-MCL-R-P

Connection boxes

	Order code
Connection box for Receivers and Transceivers	F39-TGR-MCL-CMD
Connection box for Transmitters	F39-TGR-MCL-CML

Mounting brackets

	Order code
Mounting bracket for one muting actuator	F39-TGR-MCL-ST

Specifications

Power supply	24 VDC±20%	
Consumption	5 W max (F39-TGR-MCL- _ only)	
Ambient temperature	During operation; -10 to + 55°C (with no dew condensation)	
Cable connector	Length	30 cm pre-wired
	RX	M12 5-pin female
	TX	M12 5-pin female
Degree of protection	IP65	
Distance between muting beams	250mm	
F39-TGR-MCL	Optical data	Through-beam system
	Operating distance	0 ... 7 m; max. 0 ... 8,4 m
	Light source	Red emitting LEDs, Wavelength 630 nm
F39-TGR-MCL-R	Optical data	Polarized retro-reflective system
	Operating distance	0 ... 4 m; max. 0 ... 4,8 m
	Light source	Red emitting LEDs, Wavelength 660 nm

Configuration examples

L-muting, active/active

- 1) Safety sensor (e.g. F3S-TGR-CL4A-K2-500)
- 2) Muting actuators F39-TGR-MCL
- 3) Connector box F39-TGR-MCL-CML
- 4) Connector box F39-TGR-MCL-CMD

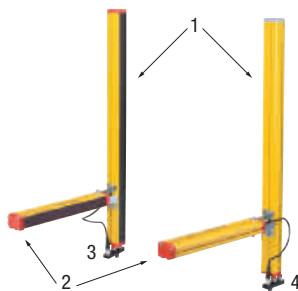

L-muting, active/passive

- 1) Safety Sensor (e.g. F3S-TGR-CL4A-K2C-500)
- 2) Muting actuators F39-TGR-MCL-R
- 3) Connection box F39-TGR-MCL-CMD

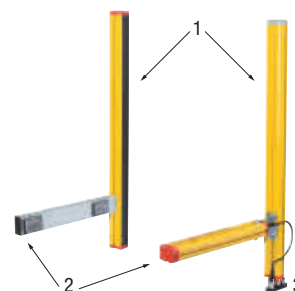



Single-beam safety sensor in compact housing

The slender M18-sized E3FS is a type 2 safety single beam with an operating range of up to 10 m. Plastic and metal housing, cable and M12-connector offer flexibility in application together with a control unit such as F3SP-U3P or F3SP-U5P.

- Sensing distance up to 10 m
- LEDs for easy alignment and diagnosis
- Cable and M12 plug categories
- Plastic and metal housing
- Type 2 sensor complying with EN 61496-1

Ordering information

Safety single beam sensors (Type 2)

Case material	Operation distance	Order code	
Plastic	0 to 10 m	Cable type	E3FS-10B4
		Plug type	E3FS-10B4-P1
Nickel brass		Cable type	E3FS-10B4-M
		Plug type	E3FS-10B4-M1-M

Controller for safety single beam sensors

Sensors	Output contacts	Width	Order code
1 to 2 Safety single beam sensors	2 NO 2.5 A	22.5 mm	F3SP-U3P-TGR
1 to 4 Safety single beam sensors		45 mm	F3SP-U5P-TGR

Specifications

Sensors

Sensing method	Through-beam
Controller	F3SP-U3P-TGR, F3SP-U5P-TGR
Supply voltage (Vs)	24 VDC \pm 10% (ripple p-p 10% max.)
Effective aperture angle (EAA)	\pm 5° (at 3 m)
Current consumption	Emitter: 50 mA max. Receiver: 25 mA max.
Sensing distance	10 m
Standard sensing object	Opaque object: 11 mm min. in diameter
Response time	2.0 ms (E3FS only)
Control output	PNP transistor output, load current: 100 mA max.
Test input (emitter)	21.5 to 24 VDC: Emitter OFF (source current: 3 mA max.) Open or 0 to 2.5 V: Emitter ON (leakage current: 0.1 mA max.)
Ambient light intensity	Incandescent lamp: 3,000 lx max. (light intensity on the receiver surface) Sunlight: 10,000 lx max. (light intensity on the receiver surface)
Ambient temperature	Operating: -20°C +55°C, storage: -30°C +70°C (with no icing or condensation)
Degree of protection	IP67 (IEC 60529)
Light source	Infrared LED
Protection	Output short-circuit protection, reverse polarity protection

Controllers

Item	F3SP-U3P	F3SP-U5P
Number of sensors	1 to 2 safety single beam sensor	1 to 4 safety single beam sensor
Width	22.5 mm	45 mm
Muting input	2 Inputs	4 Inputs
Safety related function	Override function Muting lamp connection Interlock system (automatic and manual reset)	
Power supply voltage	24 VDC \pm 10%	
Power consumption	420 mA max.	
Output contacts	2 NO 2.5 A (protected by fuse), 115 VAC max.	2 NO 2.5 A (protected by fuse), 250 VAC max.
Indicators	6 LED for status and diagnostics	
Degree of protection	IP20 (IEC 60529)	
Terminal	16 screw terminals, detachable blocks with '4pin'	32 screw terminals, detachable blocks with '4pin'
Response time	\leq 30 ms	
Ambient temperature	Operation: -10°C +55°C	
Housing material	Plastic; DIN rail mounting	



OS32C Safety laser scanner

- Type 3 safety laser scanner complies with IEC61496-1/-3
- 70 sets of safety zone and warning zone combinations are available, supporting complicated changes in working environments
- A safety radius up to 3 m and warning zone(s) radius up to 10 m can be set
- 8 Individual sector indicators and various LED indications allow the user to determine scanner status at a glance
- Reference boundary monitoring function prevents unauthorized changes in the scanner position
- Configurable minimum object resolution of 30, 40, 50 or 70 mm, for hand and arm detection applications

Ordering information

Description	Order code	Description	Remarks	Order code
OS32C with back location cable entry	OS32C-BP	Configuration tool	CD-ROM OS supported: Windows 2000, XP, Vista, Windows 7	included
OS32C with side location cable entry ^{*1}	OS32C-SP1			
OS32C with back location cable entry EtherNet/IP capable for status measurement data reporting	OS32C-BP-DM			
OS32C with side location cable entry ^{*1} EtherNet/IP capable for status measurement data reporting	OS32C-SP1-DM			

^{*1} Each connector is located on the left as viewed from the back of the I/O block.

Note: This laser scanner may not be sold or imported into or used in the Federal Republic of Germany prior to December 1, 2013.

Specifications

Sensors

Sensor type	Type 3 safety laser scanner
Safety category	Category 3, performance level d (ISO13849-1: 2006)
Detection capability	Configurable; Non-transparent with a diameter of 30, 40, 50 or 70 mm (1.8% reflectivity or greater)
Monitoring zone	Monitoring zone set count: (Safety zone + 2 warning zones) × 70 sets
Operating range	Safety Zone: 3.0 m (min. obj. resolution of 50 mm or 70 mm) 2.5 m (min. obj. resolution of 40 mm) 1.75 m (min. obj. resolution of 30 mm) Warning Zone: 10.0 m
Detection angle	270°
Response time	Response time from ON to OFF: From 80 ms (2 scans) to 680 ms (up to 17 scans) Response time from OFF to ON: Response time from ON to OFF + 100 ms to 60 s (configurable)
Line voltage	24 VDC +25%/−30% (ripple p-p 2.5 V max.)
Power consumption	Normal operation: 5 W max., 4 W typical (without output load) ^{*1} Standby mode: 3.75 W (without output load)
Safety output (OSSD)	PNP transistor × 2, load current of 250mA max., residual voltage of 2 V max., load capacity of 2.2 μf max., leak current of 1 mA max. ^{*1,*2,*3}
Auxiliary output (Non-safety)	NPN/PNP transistor × 1, load current of 100 mA max., residual voltage of 2 V max., leak current of 1 mA max. ^{*2,*3,*4}
Warning output (Non-safety)	NPN/PNP transistor × 1, load current of 100 mA max., residual voltage of 2 V max., leak current of 1 mA max. ^{*2,*3,*4}
Output operation mode	Auto start, start interlock, start/restart interlock
Input	External Device Monitoring (EDM) ON: 0 V short (input current of 50 mA), OFF: Open
	Start ON: 0 V short (input current of 20 mA), OFF: Open
	Zone select ON: 24 V short (input current of 5 mA), OFF: Open
	Stand-by ON: 24 V short (input current of 5 mA), OFF: Open
Connection type	Power cable: 18-pin mini-connector (pigtail) Communication cable: M12, 4-pin connector
Connection with PC	Communication: Ethernet
Indicators	RUN indicator: Green, STOP indicator: Red, Interlock indicator: Yellow, Warning output indicator: Orange, Status/diagnostic display: 2 × 7-segment LEDs, Intrusion indicators: Red LED × 8
Enclosure rating	IP65 (IEC60529)
Dimensions (W × H × D)	133.0 × 104.5 × 142.7 mm (except cable)
Weight (Main Unit only)	1.3 kg
Approvals	Certified by: TÜV Rheinland, UL Major standards: IEC61496-1/-3 (Type 3), IEC61508 (SIL2), ISO13849-1:2008 (Category 3, performance level d), UL508, UL1998

^{*1} Rated current of OS32C is 1.025 A max. (OS32C 210 mA + OSSD A load + OSSD B load + auxiliary output load + warning output load + functional inputs). Where functional inputs are: EDM input ... 50 mA, Start input ... 20 mA, Standby input ... 5 mA, Zone X input ... 5 mA × 8 (eight zone set select inputs).

^{*2} Output voltage is input voltage − 2.0 VDC.

^{*3} Total consumption current of 2 OSSDs, auxiliary output, and warning output must not exceed 700 mA.

^{*4} Output polarity (NPN/PNP) is configurable via the configuration tool.

Accessories (sold separately)

Power cable





Appearance	Description	Remarks	Order code
	Cable length: 3 m	One cable is required per sensor	OS32C-CBL-03M
	Cable length: 10 m		OS32C-CBL-10M
	Cable length: 20 m		OS32C-CBL-20M
	Cable length: 30 m		OS32C-CBL-30M

Ethernet cable

Appearance	Description	Remarks	Order code
	Cable length: 2 m	Required for configuration and monitoring	OS32C-ECBL-02M
	Cable length: 5 m		OS32C-ECBL-05M
	Cable length: 15 m		OS32C-ECBL-15M







Note: An ethernet cable with an M12, 4-pin connector is required.

Mounting brackets

Appearance	Description	Remarks	Order code
	Bottom/side mounting bracket	Bottom/side mounting bracket × 1, unit mounting screws × 4 sets	OS32C-BKT1
	XY axis rotation mounting bracket	XY axis rotation mounting bracket × 1, unit mounting screws × 6 sets, bracket mounting screws × 1 set (must be used with OS32C-BKT1)	OS32C-BKT2
	Simple mounting bracket	Simple mounting brackets × 2, unit mounting screws × 4 sets ^{*1}	OS32C-BKT3
	Protective cover for window		OS32C-BKT4
	Mounting stand	When using a mounting stand, use an OS32C with side location cable entry (OS32C-SP1). The OS32C with back location cable entry (OS32C-BP) cannot be mounted. Use with mounting brackets (OS32C-BKT1 and OS32C-BKT2).	OS32C-MT
	Hardware kit for mounting stand	Mounting screws × 3 sets Use this when mounting a bracket to the mounting stand.	OS32C-HDT

^{*1} There are eight OS32C mounting screws: four screws for singular use, and four screws for protective cover for window.

Miscellaneous

Appearance	Description	Remarks	Order code
	Scan window	Spare for replacement	OS32C-WIN-KT
	Sensor block without I/O block EtherNet capable for configuration and monitoring	Spare for replacement	OS32C-SN
	Sensor block without I/O block EtherNet/IP capable for status and measurement data reporting	Spare replacement for EtherNet/IP	OS32C-SN-DM
	I/O block With cable access from the back	Spare for replacement	OS32C-CBBP
	I/O block With cable access from the left side	Spare for replacement	OS32C-CBSP1
	Window cleaning kit, anti-static cleaner	Accessory	WIN-CLN-KT

Connection

Basic connection with single OS32C unit
Category 3, performance level d (ISO13849-1)

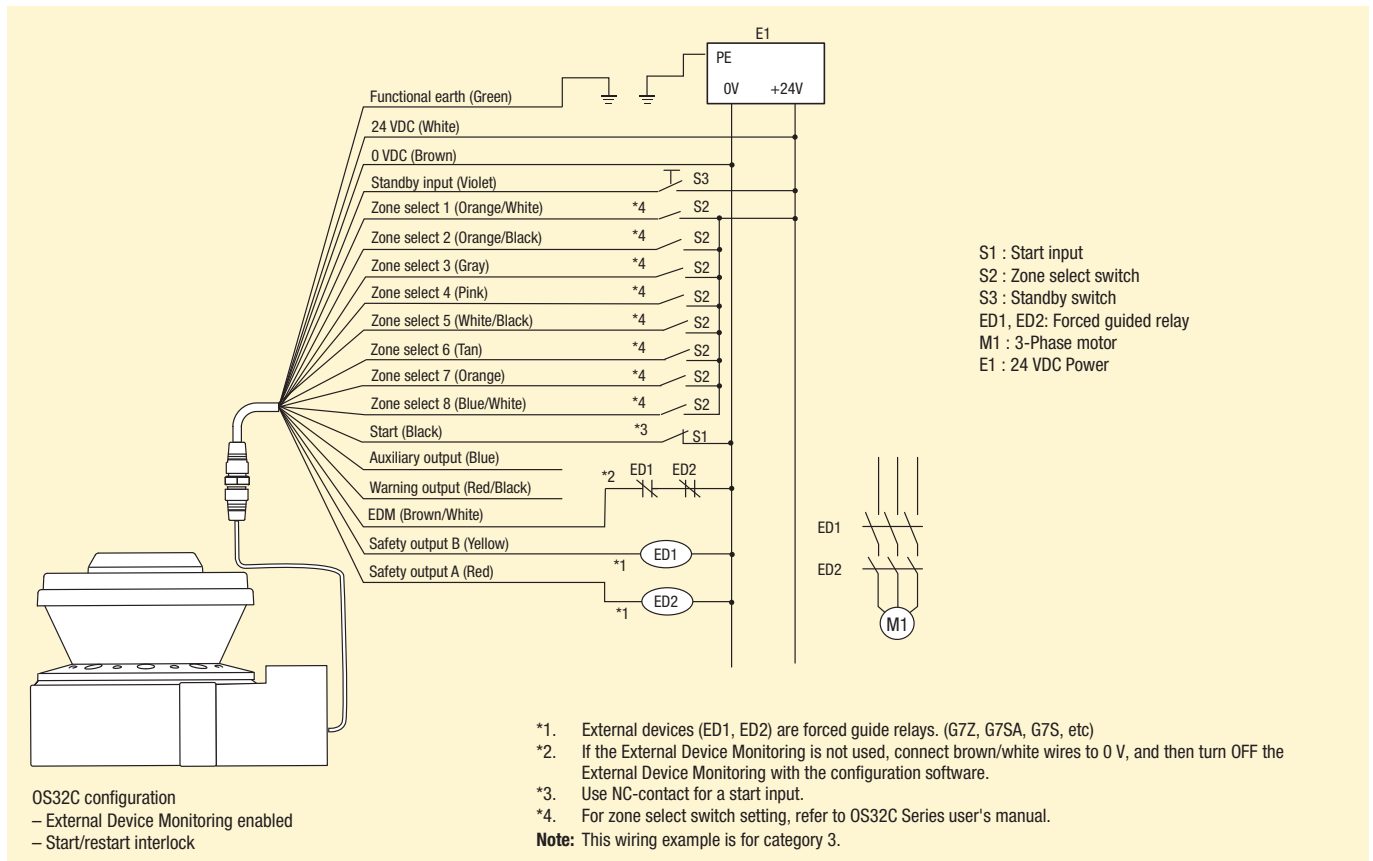

BREAK THROUGH BARRIERS IN SAFETY DESIGN

Configurable, flexible and simple



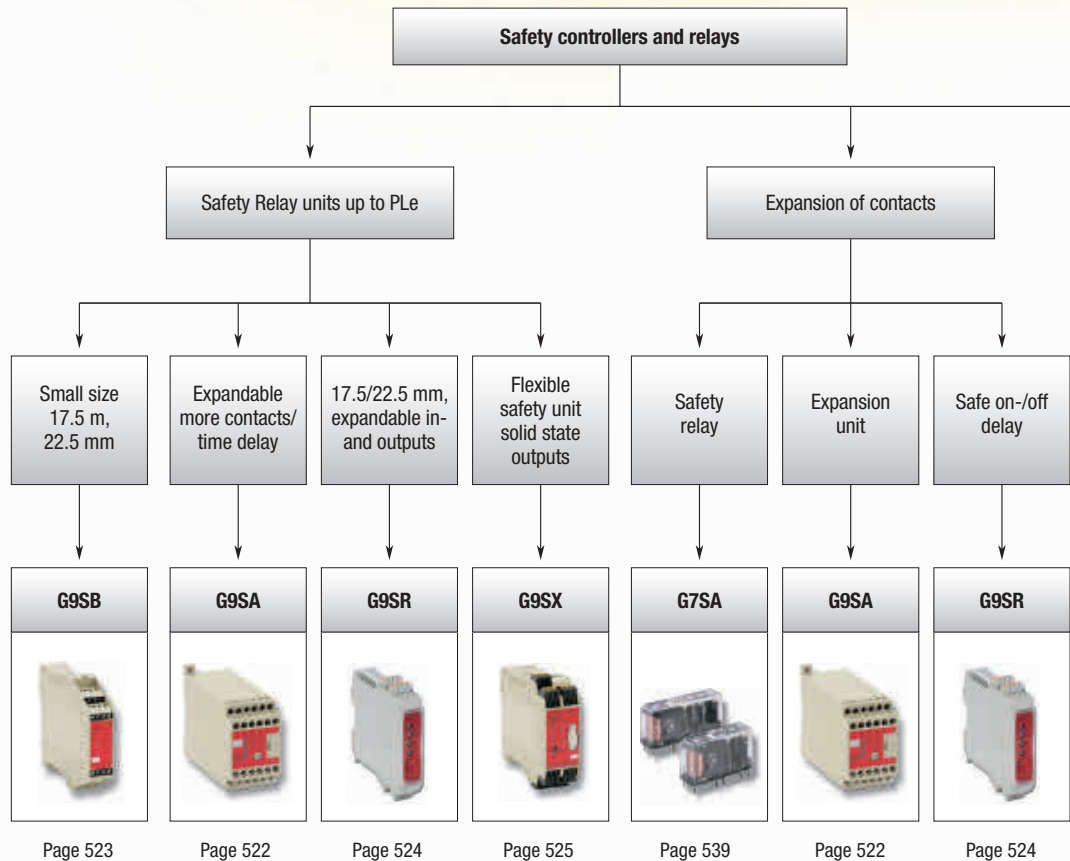

Omron safety controllers offer transparent standalone operation and scalability in safety networking applications for all sizes of machine safety control systems. The G9SP safety controller is simple to configure and setup and overcomes limitations of hard-wired solutions by adding flexibility of a software - based solution. Total cost of ownership is reduced by having user-defined function blocks and an integrated simulation tool for debugging or the application program.

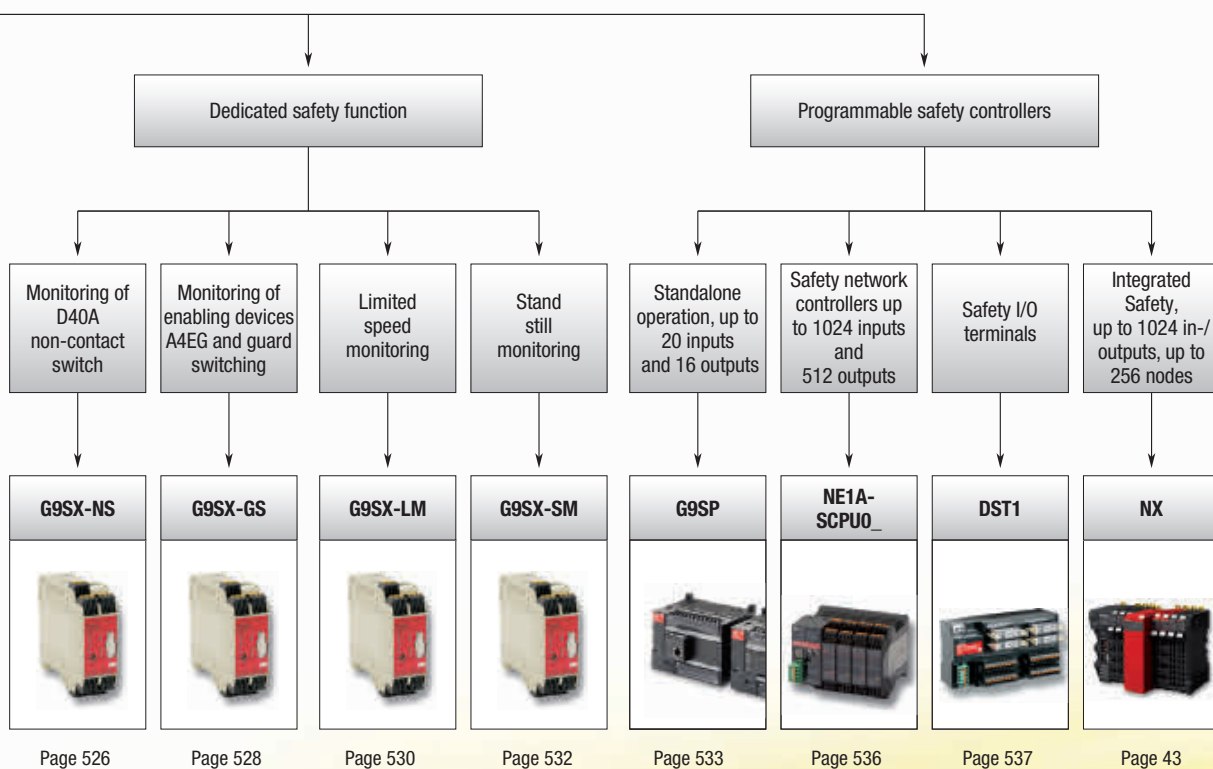



- EN ISO 13849-1 (PLe) and IEC 61508 (SIL3) certification for future-proof design of the safety system
- Predefined function blocks for simple configuration and self-explanatory validation
- Equipped with Ethernet and serial interface for transparent diagnosis





Selection table

		Safety relay units		Safety relays	Flexible safety unit
					
		G9SA	G9SB	G9SR	G9SX
Selection criteria	Model	up to PLe acc. EN ISO 13849-1 depending on application			
	Performance level	up to PLe acc. EN ISO 13849-1 depending on application			
	Safety integrity level (IEC 61508)	–	–	–	SIL 3
	Reaction time	max. 10 ms	max. 10 ms	depend on safety application	15 ms
	DeviceNet safety Bus interface	–	–	–	–
	Standard DeviceNet Bus interface	–	–	–	–
	EDM function	■	■	■	■
	Interlock function	■	■	■	■
	Logical 'AND' connection	–	–	■	■
	Relay expansion units	■	–	–	■
	Housing	Plastic	Plastic	Plastic	Plastic
	Operating temperature	–25 to 55°C	–25 to 55°C	–10 to 55°C	–10 to 55°C
	Flux-tight	–	–	–	–
Features	Number of poles	–	–	–	–
	Gold clad contacts	–	–	–	–
	Relay socket	–	–	–	–
	Detachable cage clamp terminals	–	–	■	■
	Screw terminals	■	■	optional	■
	Safe timing functions	■	–	on-delay and off-delay	■
	USB-interface	–	–	–	–
Application	Programming software	–	–	–	–
	E-Stop application	■	■	■	■
	Door switch monitoring	■	■	■	■
	Safety light curtain monitoring	■	■	■	■
	EDM monitoring	■	■	■	■
	Interlock function	■	■	■	■
	Logic function blocks	–	–	■	–
	Safe ON delay timer	–	–	■	–
	Safe OFF delay timer	■	–	■	■
	Two-Hand control	■	–	■	–
	Manual/automatic reset	■	■	■	■
	Non-contact switches monitoring	–	–	■	■
	Guard switching/enabling function	–	–	■	■
	limited speed monitoring	–	–	–	■
	standstill monitoring	–	–	–	■
Supply voltage	General safety application	■	■	■	■
	24 VDC	■	■	■	■
In- and outputs	100 VAC to 240 VAC	■	–	–	–
	Safety inputs	■	■	■	■
	Test signal output	–	–	■	■
	Solid state safety outputs	–	–	■	■
	Safety relay outputs	3PST-NO, 5PST-NO	DPST-NO, 3PST-NO	DPST-NO, 3PST-NO	■
	Auxiliary outputs	SPST-NC	SPST-NC	Solid state, SPST-NO	■
	4PST-NO + DPST-NC	–	–	–	–
	3PST-NO + 3PST-NC	–	–	–	–
	3PST-NO + SPST-NC	–	–	–	–
	DPST-NO + DPST-NC	–	–	–	–
5PST-NO + SPST-NC	–	–	–	–	
Page	522	523	524	525	

		Safety relays	Programmable safety system			
						
		G7SA	G9SP	NE1A-SCPU0_	DST1	
Selection criteria	Model					
	Performance level	–	up to PLe acc. EN ISO 13849-1 depending on application			
	Safety integrity level (IEC 61508)	–	SIL 3			
	Reaction time	–	dependent on safety application program			
	DeviceNet safety Bus interface	–	–	■	■	
	Standard DeviceNet Bus interface	–	Diagnosis via Ethernet and Serial interface (option)			
	EDM function	–	■	■	■	
	Interlock function	–	■	■	■	
	Logical 'AND' connection	–	–	–	–	
	Relay expansion units	–	–	–	–	
	Housing	Plastic	Plastic	Plastic	Plastic	
	Operating temperature	–40 to 85°C	–10 to 55°C	–10 to 55°C	–10 to 55°C	
	Features	Flux-tight	■	–	–	–
Number of poles		4pole and 6pole	–	–	–	
Gold clad contacts		■	–	–	–	
Relay socket		■	–	–	–	
Detachable cage clamp terminals		–	–	■	■	
Screw terminals		–	■	–	–	
Safe timing functions		–	■	■	■	
USB-interface		–	■	■	–	
Programming software		–	■	■	–	
Application		E-Stop application	–	■	■	■
		Door switch monitoring	–	■	■	■
		Safety light curtain monitoring	–	■	■	■
		EDM monitoring	–	■	■	■
	Interlock function	–	■	■	■	
	Logic function blocks	–	■	■	■	
	Safe ON delay timer	–	■	■	■	
	Safe OFF delay timer	–	■	■	■	
	Two-Hand control	–	■	■	■	
	Manual/automatic reset	–	■	■	■	
	Non-contact switches monitoring	–	■	■	■	
	Guard switching/enabling function	–	■	■	■	
	Supply voltage	limited speed monitoring	–	–	–	■
standstill monitoring		–	–	–	■	
General safety application		■	■	■	■	
24 VDC		■	■	■	■	
100 VAC to 240 VAC		–	–	–	–	
In- and outputs		Safety inputs	–	■	■	■
		Test signal output	–	■	■	■
		Solid state safety outputs	–	■	■	■
		Safety relay outputs	–	–	–	■
		Auxiliary outputs	–	■	■	■
		4PST-NO + DPST-NC	■	–	–	–
		3PST-NO + 3PST-NC	■	–	–	–
		3PST-NO + SPST-NC	■	–	–	–
	DPST-NO + DPST-NC	■	–	–	–	
5PST-NO + SPST-NC	■	–	–	–		
Page	539	533	536	537		

■ Standard

– No/not available



Expandable safety relay unit

G9SA-family offers a complete line-up of compact and expandable safety relay units. Modules with safe OFF-delay timing are available as well as a two-hand controller. Simple multiplication of safety contacts is possible by using the connection on the front.

- 45 mm-wide housing, expansion units are 17.5 mm wide
- Safe OFF-delay timer
- Simple expansion connection
- Certification up to PLe according to EN ISO 13849-1 depending on the application

Ordering information

Emergency-stop units

Main contacts	Auxiliary contact	Number of input channels	Rated voltage	Order code
3PST-NO	SPST-NC	1 channel or 2 channels possible	24 VAC/VDC 100 to 240 VAC	G9SA-301
5PST-NO	SPST-NC	1 channel or 2 channels possible	24 VAC/VDC 100 to 240 VAC	G9SA-501

Emergency-stop OFF-delay units

Main contacts	OFF-delay contacts	Auxiliary contact	Number of input channels	OFF-delay time	Rated voltage	Order code
3PST-NO	DPST-NO	SPST-NC	1 channel or 2 channels possible	7.5 s	24 VAC/VDC 100 to 240 VAC	G9SA-321-T075
				15 s	24 VAC/VDC 100 to 240 VAC	G9SA-321-T15
				30 s	24 VAC/VDC 100 to 240 VAC	G9SA-321-T30

Two-hand controller

Main contacts	Auxiliary contact	Number of input channels	Rated voltage	Order code
3PST-NO	SPST-NC	2 channels	24 VAC/VDC 100 to 240 VAC	G9SA-TH301

Expansion unit

The expansion unit connects to a G9SA-301, G9SA-501, G9SA-321, or G9SA-TH301.

Main contacts	Auxiliary contact	Category	Order code
3PST-NO	SPST-NC	4	G9SA-EX301

Expansion units with OFF-delay outputs

The expansion unit connects to a G9SA-301, G9SA-501, G9SA-321, or G9SA-TH301.

Main contact form	Auxiliary contact	OFF-delay time	Order code
3PST-NO	SPST-NC	7.5 s	G9SA-EX031-T075
		15 s	G9SA-EX031-T15
		30 s	G9SA-EX031-T30

Specifications

Power input

Item	G9SA-301/TH301 / G9SA-501 / G9SA-321-T_
Power supply voltage	24 VAC/VDC: 24 VAC, 50/60 Hz, or 24 VDC 100 to 240 VAC: 100 to 240 VAC, 50/60 Hz
Operating voltage range	85 to 110% of rated power supply voltage

Inputs

Item	G9SA-301/321-T_/TH301	G9SA-501
Input current	40 mA max.	60 mA max.

Contacts

Item	G9SA-301/501/321-T_/TH301/EX301/EX031-T_
	Resistive load (cosφ= 1)
Rated load	250 VAC, 5 A
Rated carry current	5 A

Characteristics

Item	G9SA-301/TH301 / G9SA-501/321-T_ / G9SA-EX301/EX031-T_	
Operating time	30 ms max. (not including bounce time)	
Response time ^{*1}	10 ms max. (not including bounce time)	
Durability	Mechanical	5,000,000 operations min. (at approx. 7,200 operations/hr)
	Electrical	100,000 operations min. (at approx. 1,800 operations/hr)
Minimum permissible load (reference value)	5 VDC, 1 mA	
Ambient temperature	Operating: -25 to 55°C (with no icing or condensation) Storage: -25 to 85°C (with no icing or condensation)	

^{*1} The response time is the time it takes for the main contact to open after the input is turned OFF.



Slim-size safety unit

G9SB is a family of slender safety relay units, providing two safety contacts in a 17.5 mm- and three safety contacts in a 22.5mm-wide housing.

- 17.5 mm- and 22.5 mm-wide housing
- 1- and 2-input channel units
- Manual and automatic reset units
- Certification up to PLE according to EN ISO 13849-1 depending on the application

Ordering information

Main contacts	Auxiliary contact	Number of input channels	Reset mode	Input type	Rated voltage	Size (HxWxD)	Order code	
DPST-NO 2 safety contacts	None	2 channels	Auto-reset	Inverse	24 VAC/VDC	100 mmx17.5 mmx112 mm	G9SB-2002-A	
		1 channel or 2 channels		+ common			G9SB-200-B	
		2 channels	Manual-reset	Inverse			G9SB-2002-C	
		1 channel or 2 channels		+ common			G9SB-200-D	
3PST-NO 3 safety contacts	SPST-NC	None (direct breaking)	Auto-reset	-	24 VDC	100 mmx17.5 mmx112 mm	G9SB-3010	
		2 channels		Inverse	+ common	24 VAC/VDC	100 mmx22.5 mmx112 mm	G9SB-3012-A
		1 channel or 2 channels						G9SB-301-B
		2 channels	Manual-reset	Inverse	+ common			G9SB-3012-C
		1 channel or 2 channels						G9SB-301-D

Specifications

Power input

Item	G9SB-200 _ _	G9SB-3010	G9SB-301 _ _
Power supply voltage	24 VAC/VDC: 24 VAC, 50/60 Hz, or 24VDC 24 VDC: 24 VDC		
Operating voltage range	85 to 110% of rated power supply voltage		
Power consumption	1.4 VA/1.4 W max.	1.7 W max.	1.7 VA/1.7 W max.

Inputs

Item	G9SB-200 _ _	G9SB-3010	G9SB-301 _ _
Input current	25 mA max.	60 mA max. (See note.)	30 mA max.

Note: Indicates the current between terminals A1 and A2.

Contacts

Item	G9SB-200 _ _	G9SB-3010	G9SB-301 _ _
Resistive load (cosφ= 1)			
Rated load	250 VAC, 5 A		
Rated carry current	5 A		

Characteristics

Item	G9SB-200 _ _	G9SB-3010	G9SB-301 _ _
Response time *1	10 ms max.		
Durability	Mechanical	5,000,000 operations min. (at approx. 7,200 operations/hr)	
	Electrical	100,000 operations min. (at approx. 1,800 operations/hr)	
Minimum permissible load (reference value)	5 VDC, 1 mA		
Ambient operating temperature	-25°C +55°C (with no icing or condensation)		

*1 The response time is the time it takes for the main contact to open after the input is turned OFF.



Compact safety relay unit family

G9SR family modules operate standalone and as a system with input and output extension. All modules are simple to set up using DIP-switches and provide clear diagnosis via LEDs on the front.

- Three modules for all safety relay unit applications
- Solid-state outputs for long life and high current safety relay outputs
- Detailed LED indications enable easy diagnosis
- Safe on- and off-delay function up to PLe
- Up to PLe according to EN ISO 13949-1 and SIL 3 according to EN 61508

Ordering information

Advanced unit

Safety outputs	Auxiliary outputs	No. of input channels	Rated voltage	Terminal block type	Order code
Instantaneous					
2 PST-NO (contact)	1 PNP transistor outputs	1 or 2 channels	24 VDC	removable cage clamp terminals	G9SR-AD201-RC

Basic unit

Safety outputs	Auxiliary outputs	No. of input channels	Rated voltage	Terminal block type	Order code
Instantaneous					
2 P channel MOS FET transistor output	1 PNP transistor output	1 or 2 channels	24 VDC	removable cage clamp terminals	G9SR-BC201-RC

Expansion unit

Safety outputs		Auxiliary outputs	Rated voltage	Terminal block type	Order code
Instantaneous	ON/OFF-delayed				
–	3 PST-NO (contact) ^{*1}	1 (solid state) PNP transistor outputs	24 VDC	removable cage clamp terminals	G9SR-EX031-T90-RC

^{*1} The ON/OFF delay time can be set in 16 steps as follows: 0/0.1/0.2/0.5/1/1.5/2/2.5/5/10/20/30/45/60/75/90 s

Specifications

Power input

Item	G9SR-AD_	G9SR-BC_	G9SR-EX_
Rated supply voltage	19.2 to 28.8 VDC (24 VDC ±20%)		

Inputs

Item	G9SR-AD_	G9SR-BC_	G9SR-EX_
Safety input	Operating voltage: 19.2 VDC to 28.8 VDC, internal impedance: Approx. 3 kΩ		
Feedback/reset input			

Outputs

Item	G9SR-BC202-_
Instantaneous safety output	P channel MOS FET transistor output Load current: Using 2 outputs: 2 A DC max.
Auxiliary output	PNP transistor output Load current: 500 mA max.

Expansion unit

Item	G9SR-AD_	G9SR-EX_
Rated load	250 VAC, 5 A AC15 (inductive load)	
Rated carry current	6 A	
Maximum switching voltage	250 VAC	

Characteristics

Item	G9SR-AD_	G9SR-BC_	G9SR-EX_
Operating time (OFF to ON state)	150 ms max.		
Response time (ON to OFF state)	50 ms max.		
Durability	Electrical	–	
	Mechanical	–	
Ambient temperature	–10°C +55°C (with no icing or condensation)		



Flexible safety unit

G9SX-family modules can be connected by a logical "AND" function to implement partial/global stopping of a machine. Solid-state outputs, detailed LED diagnosis and clever feedback signals help to keep maintenance easy. The line-up is completed by expansion units with safe timing functions.

- Clear and transparent segmentation of safety functions by use of unique "AND" connection
- Solid-state outputs for long life and relay outputs in extension box available
- Detailed LED indications enable easy diagnosis
- Clever feedback signals for easy maintenance
- PLe according to EN ISO 13849-1 and SIL 3 according to EN 61508

Ordering information

Advanced unit

Safety outputs		Auxiliary outputs	No. of input channels	Max. OFF-delay time ^{*1}	Rated voltage	Terminal block type	Order code
Instantaneous	OFF-delayed						
3 P channel MOS-FET transistor output	2 P channel MOS-FET transistor output	2 PNP transistor outputs	1 or 2 channels	0 to 15 sec in 16 steps	24 VDC	Screw terminals Cage clamp terminals	G9SX-AD322-T15-RT G9SX-AD322-T15-RC
2 P channel MOS-FET transistor output	2 P channel MOS-FET transistor output	2 PNP transistor outputs	1 or 2 channels	0 to 150 sec in 16 steps	24 VDC	Screw terminals Cage clamp terminals	G9SX-AD-322-T150-RT G9SX-AD-322-T150-RC
				0 to 15 sec in 16 steps	24 VDC	Screw terminals Cage clamp terminals	G9SX-ADA-222-T15-RT G9SX-ADA-222-T15-RC
				0 to 150 sec in 16 steps	24 VDC	Screw terminals Cage clamp terminals	G9SX-ADA-222-T150-RT G9SX-ADA-222-T150-RC
				0 to 150 sec in 16 steps	24 VDC	Screw terminals Cage clamp terminals	G9SX-ADA-222-T150-RT G9SX-ADA-222-T150-RC

*1 The OFF-delay time can be set in 16 steps as follows: T15: 0/0.2/0.3/0.4/0.5/0.6/0.7/1/1.5/2/3/4/5/7/10/15 s, T150: 0/10/20/30/40/50/60/70/80/90/100/110/120/130/140/150 s.

Basic unit

Safety outputs		Auxiliary outputs	No. of input channels	Rated voltage	Terminal block type	Order code
Instantaneous	OFF-delayed					
2 P channel MOS FET transistor output	–	2 PNP transistor output	1 or 2 channels	24 VDC	Screw terminals Cage clamp terminals	G9SX-BC202-RT G9SX-BC202-RC

Expansion unit

Safety outputs		Auxiliary outputs	OFF-delay time	Rated voltage	Terminal block type	Order code
Instantaneous	OFF-delayed					
4 PST-NO (contact)	–	2 (solid state) PNP transistor outputs	–	24 VDC	Screw terminals Cage clamp terminals	G9SX-EX401-RT G9SX-EX401-RC
–	4 PST-NO (contact)		Synchronized with G9S-X-AD - unit		Screw terminals Cage clamp terminals	G9SX-EX041-T-RT G9SX-EX041-T-RC

Specifications

Power input

Item	G9SX-AD	G9SX-BC202-	G9SX-EX-
Rated supply voltage	20.4 to 26.4 VDC (24 VDC -15% +10%)		

Inputs

Item	G9SX-AD	G9SX-BC202-
Safety input	Operating voltage: 20.4 VDC to 26.4 VDC, internal impedance: Approx. 2.8 kΩ	
Feedback/reset input		

Outputs

Item	G9SX-AD	G9SX-BC202-
Instantaneous safety output	P channel MOS FET transistor output	
OFF-delayed safety output	Load current: Using 2 outputs or less: 1 A DC max. Using 3 outputs or more: 0.8 A DC max.	
Auxiliary output	PNP transistor output Load current: 100 mA max.	

Expansion unit

Item	G9SX-EX-
Rated load	250 VAC, 3A/30 VDC, 3A (resistive load)
Rated carry current	3 A
Maximum switching voltage	250 VAC, 125 VDC

Characteristics

Item	G9SX-AD	G9SX-BC202-	G9SX-EX-
Operating time (OFF to ON state)	50 ms max. (Safety input: ON) 100 ms max. (Logical AND connection input: ON)		30 ms max.
Response time (ON to OFF state)	15 ms max.		10 ms max.
Durability	Electrical	–	100,000 cycles min.
	Mechanical	–	5,000,000 cycles min.
Ambient temperature	-10°C +55°C (with no icing or condensation)		



Compact non-contact door switch/ flexible safety unit

Electronic detection mechanism for better stability in non-contact door switch operation.

- Stable operation reduces controller errors caused by unstable doors.
- Connect up to 30 non-contact door switches with LED indicators to one controller.
- Reversible switch provides flexibility in installation.
- Two-colour LED indicator enables easier maintenance by identification of door status and cable disconnections.

Ordering information

Non-contact door switches (switch/actuator)

Classification	Auxiliary outputs	Cable length	Order code
Standard models	Semiconductor outputs *1	2 m	D40A-1C2
		5 m	D40A-1C5
		Pigtail with M12 connector 4-pole	D40A-1C015-F

*1 PNP open-collector semiconductor output.

Note: Must be used in combination with a G9SX-NS_ non-contactdoor switch controller.

Non-contact door switch controllers (Controllers for D40A)

Safety outputs *1	Auxiliary outputs *2	Logical AND connection input	Logical AND connection output	Max. OFF delay time *3	Rated voltage	Terminal block type	Order code
2 (Semi-conductors)	2 (Semi-conductors)	1	1	-	24 VDC	Screw terminals	G9SX-NS202-RT
						Spring-cage terminals	G9SX-NS202-RC
	2 (Semi-conductors)			3.0 s		Screw terminals	G9SX-NSA222-T03-RT
						Spring-cage terminals	G9SX-NSA222-T03-RC

*1 P channel MOS FET transistor output

*2 PNP transistor output

*3 The OFF-delay time can be set in 16 steps as follows:
0/0.2/0.3/0.4/0.5/0.6/0.7/0.8/0.9/1.0/1.2/1.4/1.8/2.0/2.5/3.0 s

*4 The OFF-delayed output becomes an instantaneous output by setting the OFF-delay time to 0 s.

Specifications

Ratings/characteristics of non-contact door switches

Item	Model	D40A-1C_
Operating characteristics *1	Operating distance OFF→ON	5 mm min.
	Operating distance ON→OFF	15 mm max.
	Differential travel (max.)	20% of operating distance
Ambient operating temperature		-10 to 55°C (no icing or condensation)
Vibration resistance		10 to 55 to 10 Hz (single amplitude: 0.75 mm, double amplitude: 1.5 mm)
Shock resistance		300 m/s ² min.
Degree of protection		IP67
Material		PBT resin
Mounting method		M4 screws
Power consumption		0.6 W max.
Auxiliary outputs *2		24 VDC, 10 mA (PNP open-collector outputs)
LED indicators		Actuator not detected (red); actuator detected (yellow)
Connection cables		2 m, 5 m
Number of connectable switches		30 max. (wiring length: 100 m max.)

*1 This is the distance where the switch operates from OFF to ON when approaching and the distance where the switch operates from ON to OFF when separating when the switch and actuator target marks are on the same axis, and the sensing surfaces coincide.

*2 Turns ON when the actuator is approaching.

Ratings of non-contact door switch controllers

Power input

Item	G9SX-NS202- __	G9SX-NSA222-T03- __	G9SX-EX- __
Rated supply voltage	24 VDC		

Inputs

Item	G9SX-NS202- __ /G9SX-NSA222-T03- __
Safety input ^{*1}	Operating voltage: 20.4 VDC to 26.4 VDC, internal impedance: approx. 2.8 kΩ
Feedback/reset input	

^{*1} Only applies to the G9SX-NSA222-T03-_{_}. Refers to input other than that from the non-contact door switch.

Outputs

Item	G9SX-NS202- __ /G9SX-NSA222-T03- __
Instantaneous safety output OFF-delayed safety output	P channel MOS FET transistor output Load current: 0.8 A DC max.
Auxiliary output	PNP transistor output Load current: 100 mA max.

Non-contact door switch and non-contact door switch controller wiring Example: Wiring a single switch

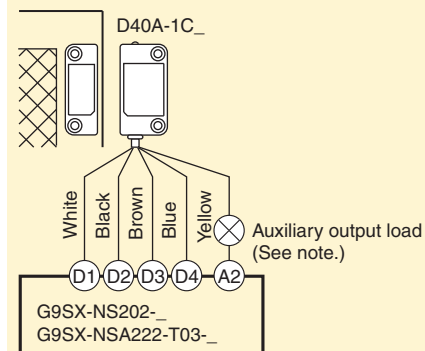

Note: The auxiliary output load current must be 10 mA max.

Example: Wiring multiple switches Connect up to 30 Non-contact door switches

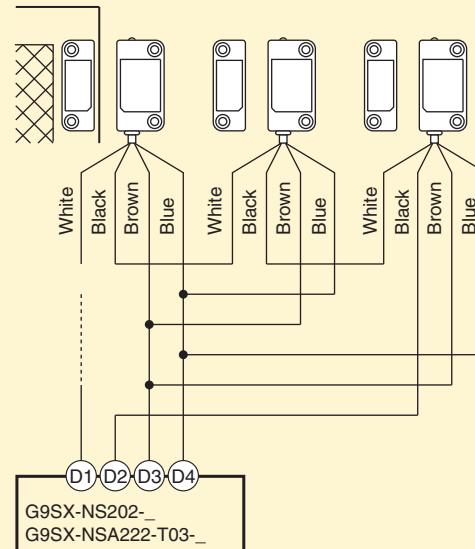



Safety guard switching unit

The safety controller to support maintenance mode of machinery in the safe way.

- Two operation modes to support:
 - Auto switching for applications where machine and worker co-operate.
 - Manual switching for applications with limitation in operation like maintenance.
- Clear and transparent segmentation of safety functions by use of unique "AND" connection
- Clear LED diagnosis of all in- and output signals for easy maintenance
- PLe according to EN ISO 13849-1 and SIL 3 according to EN 61508.

Ordering information

Enabling grip switches

Contact form			Order code
Enabling switch	Monitor switch	Pushbutton switch	
Two contacts	1NC (grip output)	None	A4EG-C000041
Two contacts	None	Emergency stop switch (2NC)	A4EG-BE2R041
Two contacts	None	Momentary operation switch (2NO)	A4EG-BM2B041

Safety guard switching units

Safety outputs ^{*1}		Auxiliary outputs ^{*2}	Logical AND connection input	Logical AND connection output	Max. OFF delay time ^{*3}	Rated voltage	Terminal block type	Order code
Instantaneous	OFF-delayed ^{*4}							
2 (Semi-conductors)	2 (Semi-conductors)	6 (Semi-conductors)	1	1	15 s	24 VDC	Screw terminals	G9SX-GS226-T15-RT
							Spring-cage terminals	G9SX-GS226-T15-RC

^{*1} P channel MOS FET transistor output

^{*2} PNP transistor output

^{*3} The OFF-delay time can be set in 16 steps as follows:

T15: 0, 0.2, 0.3, 0.4, 0.5, 0.6, 0.7, 1, 1.5, 2, 3, 4, 5, 7, 10 or 15 s

^{*4} The OFF-delayed output becomes an instantaneous output by setting the OFF-delay time to 0 s.

Specifications

Ratings of guard switching unit

Power input

Item	G9SX-GS226-T15-__	G9SX-EX-__
Rated supply voltage	24 VDC	

Inputs

Item	G9SX-GS226-T15-__
Safety input	Operating voltage: 20.4 VDC to 26.4 VDC, internal impedance: approx. 2.8 kΩ
Feedback/reset input	
Mode selector input	

Outputs

Item	G9SX-G9SX-GS226-T15-__
Instantaneous safety output	P channel MOS FET transistor output
OFF-delayed safety output	Load current: 0.8 A DC max.
Auxiliary output	PNP transistor output Load current: 100 mA max.
External indicator outputs	P channel MOS FET transistor outputs Connectable indicators <ul style="list-style-type: none"> • Incandescent lamp: 24 VDC, 3 W to 7 W • LED lamp: 10 to 300 mA DC

Application example

Automatic switching mode

Worker is loading and unloading the machine manually. When loading is finished, robot cycle is started manually by the worker. When robots return to their home position, loading cycle is selected automatically.

Loading condition: Safety sensor B is not active, safety sensor A is active because the robots are not allowed to move to the loading area while the worker loads the machine. So the worker is safe because safety sensor A is active.

Robot work condition: Safety sensor B is active, safety sensor A is not active because the worker is not allowed to move to the loading area when the robots work. So the worker is safe because safety sensor B stops the machine if he moves to the loading area.

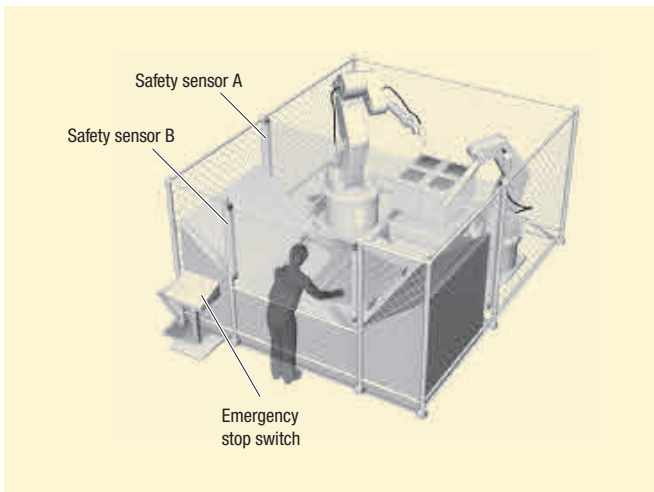

Manual switching mode

Worker has to do maintenance in this machine. While maintenance, it is necessary to move the machine in a limited way. The worker has to select automatic mode or manual mode manually by using the mode selector switch.

Operation steps:

- 1) Select maintenance mode by using the mode selector
- 2) Open the door to do the maintenance while the machine still is able to operate in a limited way (monitoring of limited movement by using the safety limit switch).
- 3) Close the cover after finishing maintenance
- 4) Select automatic mode by using the mode selector

E-Stop conditions:

- a) open the door while not in maintenance mode
- b) the machine actuates the limit switch (breaks the limit).
- c) the Enabling grip switch A4EG is actuated to stop the machine in emergency condition.

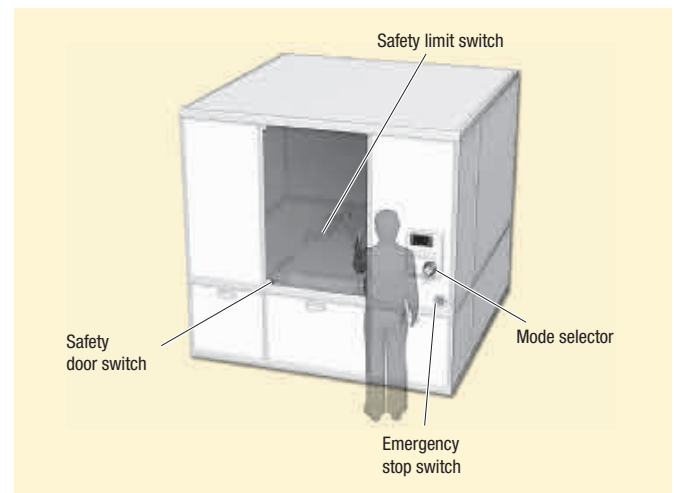

Limited speed monitoring unit



Safe limited speed monitoring unit for complete support of maintenance mode in machinery.

- Preset of limited speed frequency by using integrated preset switches
- Easy integration in G9SX-Systems by using unique logical "AND" connection
- Clear LED diagnosis of all in- and output signals for easy maintenance
- Applicable up to PLd according to EN ISO 13849-1 using Omron proximity sensors

Ordering information

Proximity sensors

Classification			Order code
Proximity sensor	Shielded	M8	E2E-X1R5F1
		M12	E2E-X2F1
		M18	E2E-X5F1
	Unshielded	M8	E2E-X2MF1
		M12	E2E-X5MF1
		M18	E2E-X10MF1

Ratings of limited speed monitoring unit

Safety outputs *1	Auxiliary outputs *2	Logical AND connection input	Rated voltage	Sensor power supply terminals	Terminal block type	Order code
Instantaneous						
4 (Semi-conductors)	4 (Semi-conductors)	1	24 VDC	2	Screw terminals	G9SX-LM224-F10-RT
					Spring-cage terminals	G9SX-LM224-F10-RC

*1 P channel MOS FET output

*2 PNP transistor output

Specifications

Ratings of limited speed monitoring unit

Power input

Item	G9SX-LM224-F10- _
Rated supply voltage	24 VDC

Inputs

Item	G9SX-LM224-F10- _
Safety input	Operating voltage: 20.4 VDC to 26.4 VDC Internal impedance: approx. 2.8 kΩ
Feedback/reset input	
Mode selector input	
Rotation detection input	Operating voltage 20.4 VDC to 26.4 VDC Internal impedance: approx. 2.8 kΩ Input frequency: 1 kHz max.

Outputs

Item	G9SX-LM224-F10- _
Safety solid state output	P channel MOS FET transistor output Load current: 0.8 A DC max.
Safety speed detection output	P channel MOS FET transistor output Load current: 0.3 A DC max.
External indicator output	PNP transistor output Load current: 100 mA max.

Application example

Safe limited speed

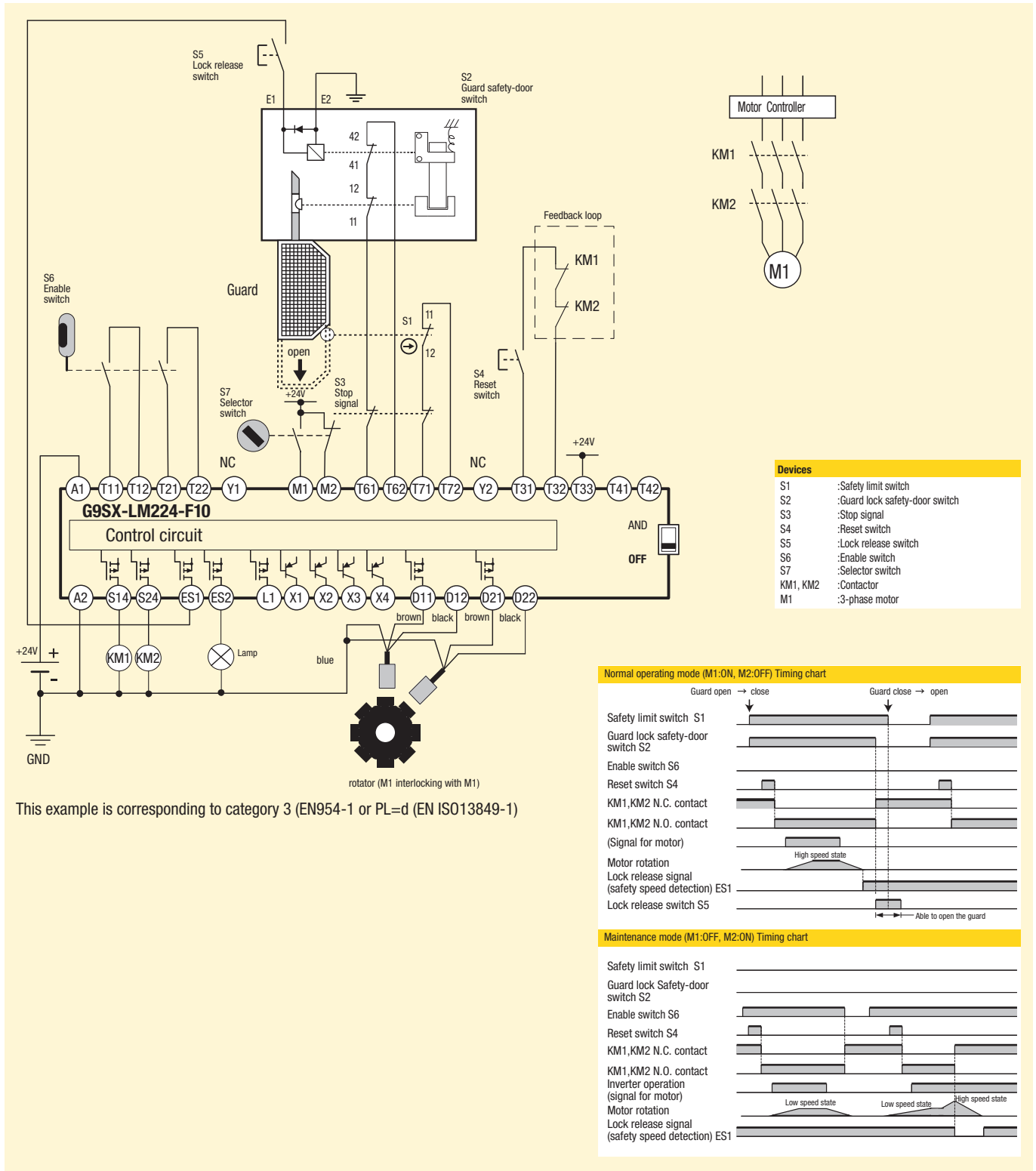



Standstill monitoring unit

Safe standstill monitoring unit based on Back-EMF operation for two- and three-phase systems.

- Ready to use – covering all standard applications without additional setup
- Easy integration in star- and delta wiring
- Clear LED diagnosis of all in- and output signals for easy maintenance
- Applicable up to PLe according to EN ISO 13849-1

Ordering information

Safety standstill monitoring unit

Safety outputs *1	Auxiliary outputs *1	Power input Rated supply voltage	Terminal block type	Order code
Instantaneous				
3 (Semi-conductors)	2 (Semi-conductors)	24 VDC	Screw terminals	G9SX-SM032-RT
			Spring-cage terminals	G9SX-SM032-RC

*1 PNP transistor output

Specifications

Ratings of standstill monitoring unit

Power input

Item	G9SX-SM032-__
Rated supply voltage	24 VDC

Inputs

Item	G9SX-SM032-__
Input voltage	Standstill detection input (Z1-Z2/Z3-Z4) AC 415 Vrms + 10% max.
Maximum power supply frequency for AC induction motor	60 Hz max.
Internal impedance	Standstill detection input: approx. 660 kΩ EDM input: approx. 2.8 kΩ

Outputs

Item	G9SX-SM032-__
Safety standstill detection output	Sourcing output (PNP) Load current: 300 mA DC max.
Auxiliary output	Sourcing output (PNP) Load current: 100 mA DC max.

Application example

3-phase motor

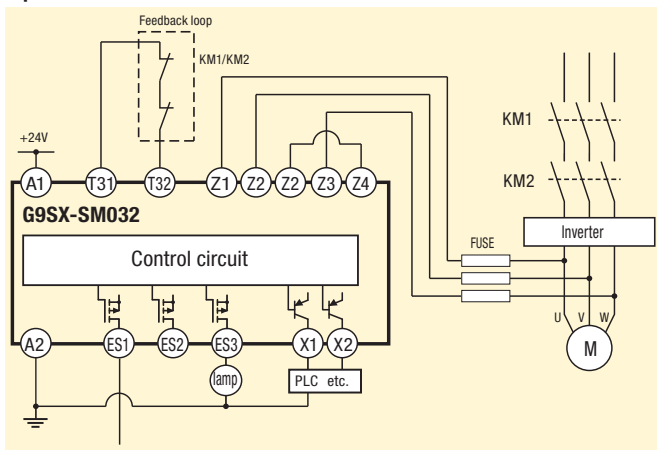

Standstill detected

3-phase motor with star-delta wiring

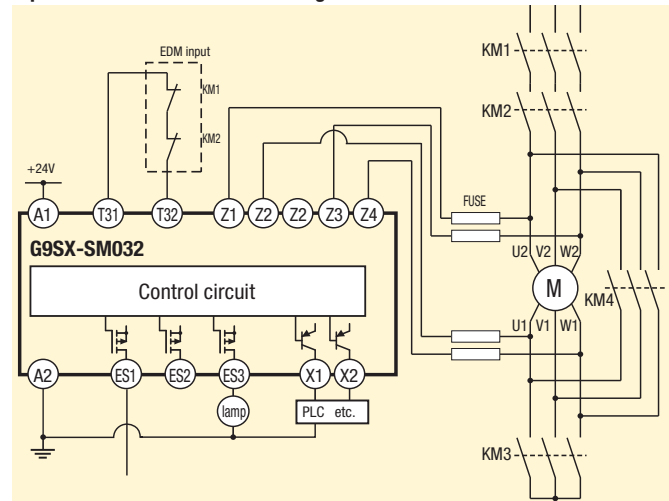

Standstill detected

Standalone safety controller

The G9SP safety controller provides all local safety based in- and outputs and controls the safety application.

- Three CPU-types to suit different applications
- Clear diagnosis and monitoring via Ethernet or serial connection
- Memory cassette for easy duplication of configuration
- Unique programming software to support easy design, verification, standardization and reuse of the program.
- Certified according to PLe (EN ISO 13849-1) and SIL 3 (IEC 61508)



Ordering information

Appearance	Appearance description	Order code
Standalone safety controller	10 PNP safety inputs 4 PNP safety outputs 4 test outputs 4 PNP standard outputs	G9SP-N10S
	10 PNP safety inputs 16 PNP safety outputs 6 test outputs	G9SP-N10D
	20 PNP safety inputs 8 PNP safety outputs 6 test outputs	G9SP-N20S

Software

Appearance	Media	Applicable OS	Order code
G9SP configurator	Setup disk 1 license	Windows 2000	WS02-G9SP01-V1
	Setup disk 10 licenses	Windows XP	WS02-G9SP10-V1
	Setup disk 50 licenses	Windows Vista	WS02-G9SP50-V1
	Setup disk Site license	Windows 7	WS02-G9SPXX-V1

Expansion units (standard I/O)

Appearance	Type	Number of I/O		Model
		In	Out	
Expansion I/O unit	Sinking	12	8 (solid state)	CP1W-20EDT
	Sourcing	12	8 (solid state)	CP1W-20EDT1
	Sinking	-	32 (solid state)	CP1W-32ET
	Sourcing	-	32 (solid state)	CP1W-32ET1
I/O Connecting cable, 80 cm long				CP1W-CN811

G9SP configuration

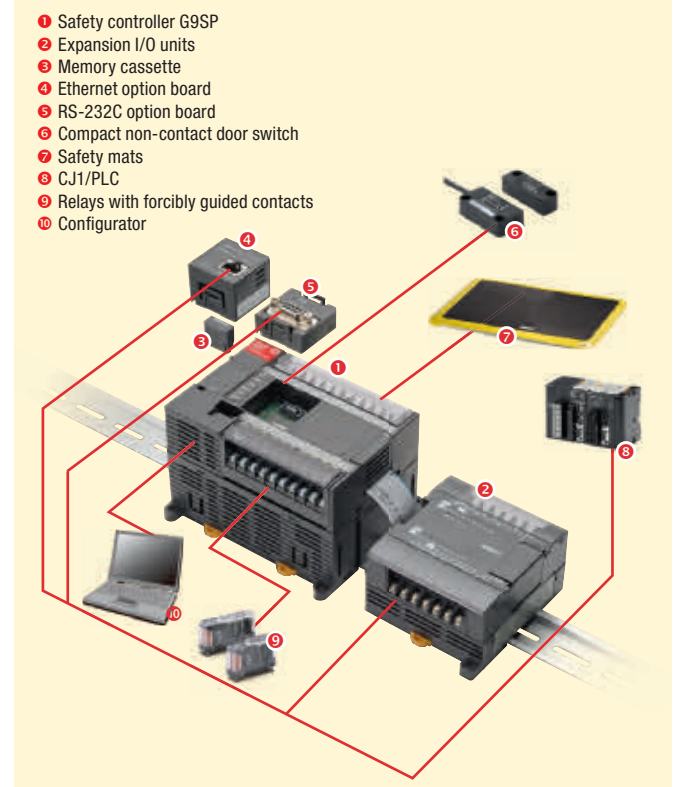

Option units

Appearance	Order code
RS-232 option board	CP1W-CIF01
Ethernet option board (Ver. 2.0 or later)	CP1W-CIF41
Memory cassette	CP1W-ME05M
G9SP Status Display Touchscreen with 1.8 m cable	82614-0010 H-T40M-P
G9SP-N10S Display Kit (G9SP, Touchscreen, cable, CP1W-CIF01)	82612-0010 G9SP-N10S-SDK
G9SP-N10D Display Kit (G9SP, Touchscreen, cable, CP1W-CIF01)	82612-0020 G9SP-N10D-SDK
G9SP-N20S Display Kit (G9SP, Touchscreen, cable, CP1W-CIF01)	82612-0030 G9SP-N20S-SDK
G9SP-N10S kit with EtherNet/IP module	82608-0010 G9SP-N10S-EIP
G9SP-N10D kit with EtherNet/IP module	82608-0020 G9SP-N10D-EIP
G9SP-N20S kit with EtherNet/IP module	82608-0030 G9SP-N20S-EIP

Specifications

General specifications

Power supply voltage		20.4 to 26.4 VDC (24 VDC -15% +10%)
Consumption current	G9SP-N10S	400 mA (V1: 300 mA, V2: 100 mA)
	G9SP-N10D	500 mA (V1: 300 mA, V2: 200 mA)
	G9SP-N20S	500 mA (V1: 400 mA, V2: 100 mA)
Mounting method		35-mm DIN track
Ambient operating temperature		0°C +55°C
Ambient storage temperature		-20°C +75°C
Degree of protection		IP20 (IEC 60529)

Safety input specifications

Input type	Sinking inputs (PNP)
ON voltage	11 VDC min. between each input terminal and G1
OFF voltage	5 VDC max. between each input terminal and G1
OFF current	1 mA max.
Input current	6 mA

Safety output specifications

Output type	Sourcing outputs (PNP)
Rated output current	0.8 A max. per output*
Residual voltage	1.2 V max. between each output terminal and V2

Test output specifications

Output type	Sourcing outputs (PNP)
Rated output current	0.3 A max. per output*
Residual voltage	1.2 V max. between each output terminal and V1

Standard output specifications (G9SP-N10S)

Output type	Sourcing outputs (PNP)
ON Residual voltage	1.5 V max. (between each output terminal and V2)
Rated output current	100 mA max.*

*For details on the rated output current, please refer to the user manual of G9SP.

Control system integration

Safety - I/O-status becomes transparent

The standalone safety controller offers diagnosis information in 3 ways:

- 1) via parallel wiring
- 2) via serial RS232C interface (option)
- 3) via Ethernet interface (option).

Information of all safety in- and outputs on the standard control system ensure minimum downtime of the machine.

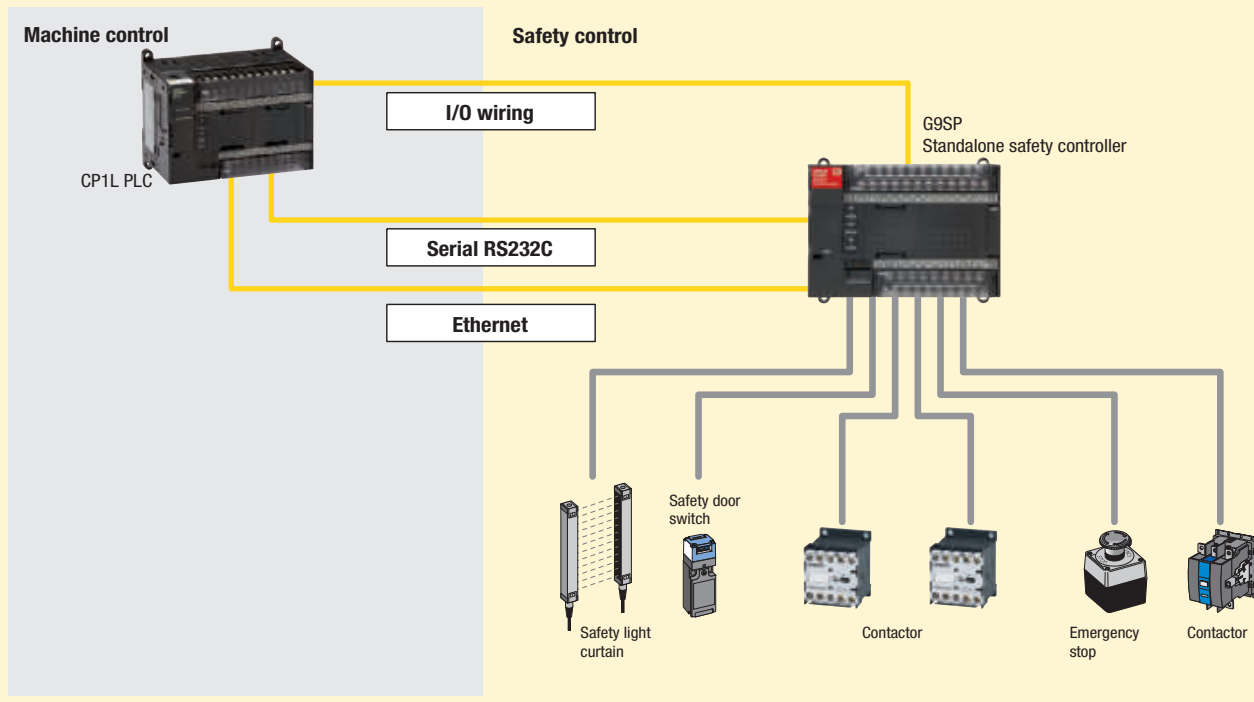

G9SP configuration tool



Easy setup and configuration is provided by a setup wizard supporting the hardware selection.

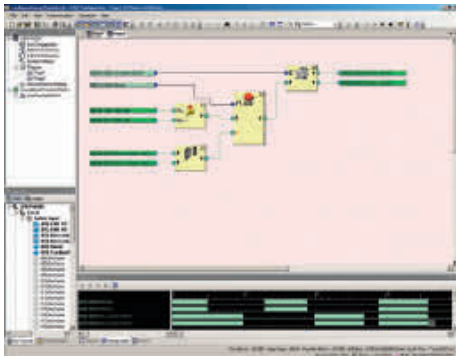

Integrated Simulator

All functions can be tested and simulated in the configuration tool, so there's no unnecessary additional workload for the engineer. In addition, on-line diagnosis reduces debug time to a minimum during implementation in the machine control system.

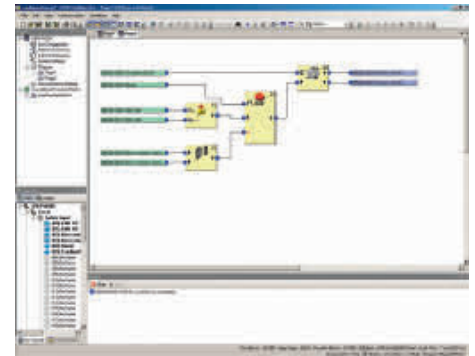

User-defined function blocks

Approved configuration elements such as a tested door monitoring solution can be easily stored as a user defined function block and re-used in future projects. This minimises the time it takes to create a new system configuration.

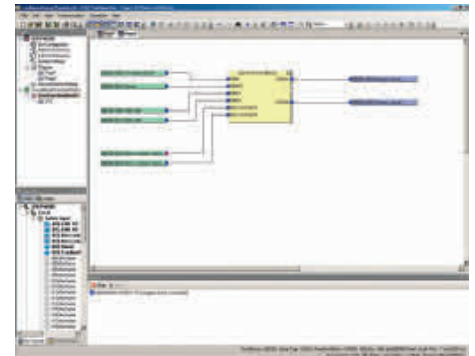

Knowledge-building

Existing configurations are the basis for new projects. The G9SP configuration tool supports re-use of existing and proven know-how in safety control, as well as user-defined function blocks. Which means no more repetition of effort, instead a growing library of safety solutions.



Safety network controller NE1A

The NE1A hosts the safety application program. All local and DeviceNet safety-based in- and outputs are monitored and controlled by the NE1A. It manages up to 32 DeviceNet safety slaves and can be seamlessly integrated in a standard DeviceNet system.

- Removable cage-clamp terminals for easy installation
- Predefined and certified function blocks for easy programming
- LED display and status LEDs for advanced diagnostics
- System status on DeviceNet for easy troubleshooting and predictive maintenance
- Easy scalability through the addition of DeviceNet safety devices

Ordering information

Appearance	Appearance description	Interface	Order code
Safety network controller	16 PNP inputs 8 PNP outputs 4 test outputs 254 function block programming removable cage clamp terminals	USB and DeviceNet safety	NE1A-SCPU01-V1
		Ethernet/IP and DeviceNet safety	NE1A-SCPU01-EIP
	40 PNP inputs 8 PNP outputs 8 test outputs 254 function block programming removable cage clamp terminals	USB and DeviceNet safety	NE1A-SCPU02
		Ethernet/IP and DeviceNet safety	NE1A-SCPU02-EIP

Software

Appearance	Appearance description	Order code
Safety network configurator	Installation disk (CD-ROM) IBM PC/AT compatible Windows 2000, Windows XP, Windows 7	WS02-CFSC1-E

Accessories

Appearance	Appearance description	Order code
Network router	Ethernet/IP - DeviceNet router	NE1A-EDR01
Programming console	CF-Card slot to store configuration USB-Interface for maintenance Touchscreen for easy troubleshooting	NE1A-HDY

Specifications

General specifications

DeviceNet communications power supply voltage	11 to 25 VDC (supplied from communications connector)	
Unit power supply voltage	20.4 to 26.4 VDC (24 VDC -15% +10%)	
I/O power supply voltage		
Consumption current	Communications power supply	24 VDC, 15 mA
	Internal circuit power supply	24 VDC, 230 mA
Mounting method	35-mm DIN track	
Ambient operating temperature	-10°C +55°C	
Ambient storage temperature	-40°C +70°C	
Degree of protection	IP20 (IEC 60529)	

Safety input specifications

Input type	Sinking inputs (PNP)
ON voltage	11 VDC min. between each input terminal and G1
OFF voltage	5 VDC max. between each input terminal and G1
OFF current	1 mA max.
Input current	4.5 mA

Safety output specifications

Output type	Sourcing outputs (PNP)
Rated output current	0.5 A max. per output
Residual voltage	1.2 V max. between each output terminal and V2

Test output specifications

Output type	Sourcing outputs (PNP)
Rated output current	0.7 A max. per output (see note.)
Residual voltage	1.2 V max. between each output terminal and V1



DeviceNet safety I/O terminal block family

- Removable cage clamp terminals for easy installation
- Up to 12 inputs for safety signals
- 4 test pulse outputs to ensure crosstalk and short circuit detection
- Up to 8 safety outputs (solid state or relay)
- Status LEDs for advanced diagnostics
- Mixed mode operation (safety and standard) for all in- and outputs

Ordering information

Safety network

Expand safety I/O through networks

Safety components distributed over many different installation locations required long and complicated wiring. Replacing the wiring with a network between safety components greatly improves productivity.

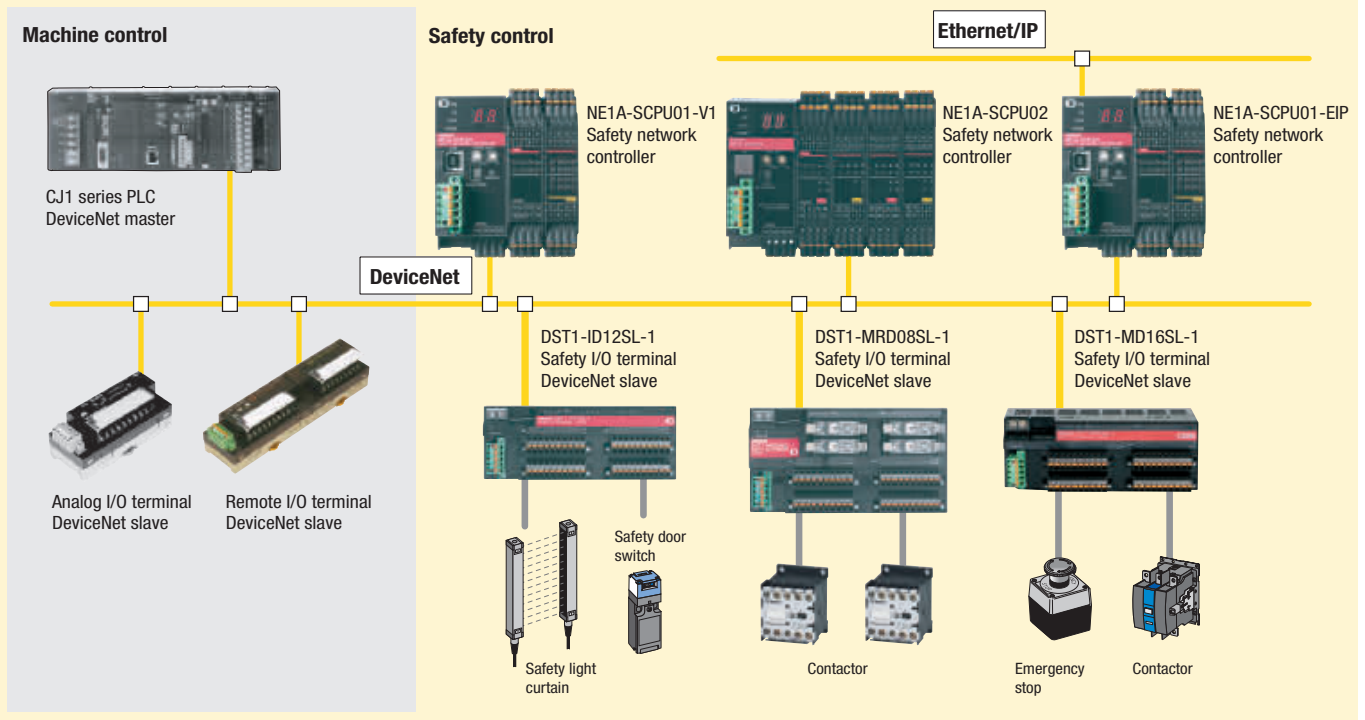

Appearance	Appearance description	Order code
Input terminal	12 PNP inputs 4 Test outputs Removable cage clamp terminals	DST1-ID12SL-1
Mixed I/O terminal	8 PNP inputs 8 PNP outputs 4 Test outputs Removable cage clamp terminals	DST1-MD16SL-1
Mixed I/O terminal	4 PNP inputs 4 relay outputs (4×2-single pole) 4 Test outputs Removable cage clamp terminals	DST1-MRD08SL-1

Specifications

General specifications

DeviceNet communications power supply voltage	11 to 25 VDC (supplied from communications connector)
Unit power supply voltage	20.4 to 26.4 VDC (24 VDC -15% +10%)
I/O power supply voltage	
Consumption current	DST1-ID12SL-1/MD16SL-1: 100 mA
Communications power supply	DST1-MRD08SL-1: 110 mA
Mounting method	35-mm DIN track
Ambient operating temperature	-10°C +55°C
Ambient storage temperature	-40°C +70°C
Degree of protection	IP20 (IEC 60529)
Weight	DST1-ID12SL-1/MD16SL-1: 420 g
	DST1-MRD08SL-1: 600 g

Safety input specifications

Input type	Sinking inputs (PNP)
ON voltage	11 VDC min. between each input terminal and G1
OFF voltage	5 VDC max. between each input terminal and G1
OFF current	1 mA max.
Input current	6 mA

Safety output specifications

Output type	Sourcing outputs (PNP)
Rated output current	0.5 A max. per output
Residual voltage	1.2 V max. between each output terminal and V1

Test output specifications

Output type	Sourcing outputs (PNP)
Rated output current	0.7 A max. per point
Residual voltage	1.2 V max. between each output terminal and V0

Safety output specifications for relay outputs

Relays	G7SA-2A2B, EN 50205 class A
Minimum applicable load	1 mA at 5 VDC
Rated load for a resistive load	240 VAC: 2 A, 30 VDC: 2 A
Rated load for an inductive load	2 A at 240 VAC (cosφ= 0.3), 1 A at 24 VDC
Mechanical life expectancy	5,000,000 operations min. (switching frequency of 7,200 operations/h)
Electrical life expectancy	100,000 operations min. (at rated load and switching frequency of 1,800 operations/h)

Safety I/O terminals

DST1-ID12SL-1

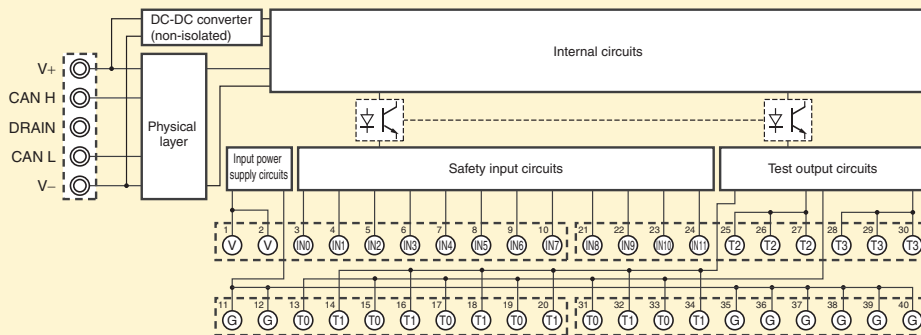

DST1-MD16SL-1

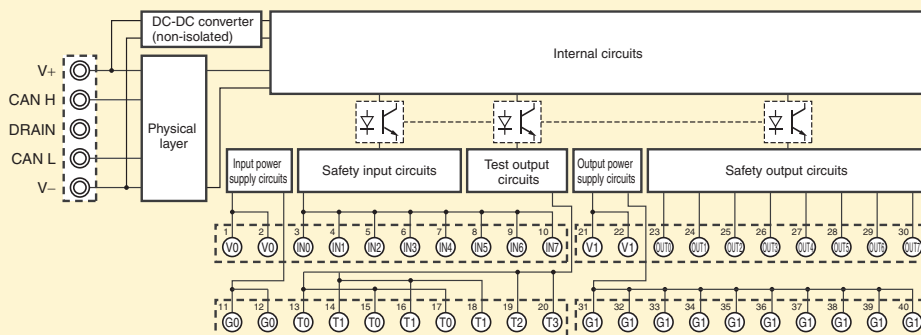

DST1-MRD08SL-1

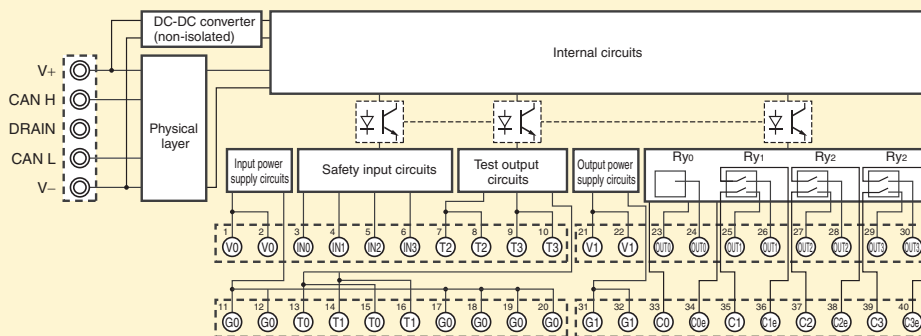

Relays with forcibly guided contacts



The slim G7SA relay family with forcibly guided contacts is available as a four- or six-pole type in various contact combinations and offers reinforced insulation. Terminals are arranged for easy PCB layout. It can be soldered directly to a PCB or used together with the P7SA sockets.

- Forcibly guided contacts
- Conforms to EN 50205
- 6 A at 240 VAC and 6A at 24 VDC for resistive loads
- Reinforced insulation between inputs and outputs and poles
- 4- and 6-pole relays available

Ordering information

Relays with forcibly guided contacts

Type	Sealing	Poles	Contacts	Rated voltage	Order code
Standard	Flux-tight	4 poles	3PST-NO, SPST-NC	24 VDC ^{*1}	G7SA-3A1B
			DPST-NO, DPST-NC		G7SA-2A2B
		6 poles	5PST-NO, SPST-NC		G7SA-5A1B
			4PST-NO, DPST-NC		G7SA-4A2B
			3PST-NO, 3PST-NC		G7SA-3A3B

^{*1} 12 VDC, 21 VDC, 48 VDC are available on request.

Sockets

Type	LED indicator	Poles	Rated voltage	Order code
Track-mounting	Track mounting and screw mounting possible	4 poles	24 VDC	P7SA-10F-ND
		6 poles		P7SA-14F-ND
Back-mounting	PCB terminals	4 poles	-	P7SA-10P
		6 poles		P7SA-14P

Specifications

Coil

Rated voltage	Rated current	Coil resistance	Must-operate voltage	Must-release voltage	Max. voltage	Power consumption
24 VDC	4 poles: 15 mA 6 poles: 20.8 mA	4 poles: 1,600 Ω 6 poles: 1,152 Ω	75% max. (V)	10% min. (V)	110% (V)	4 poles: Approx. 360 mW 6 poles: Approx. 500 mW

Note: Refer to datasheet for details

Contacts

Load	Resistive load (cosφ = 1)	Load	Resistive load (cosφ = 1)
Rated load	6 A at 250 VAC, 6 A at 30 VDC	Max. switching current	6 A
Rated carry current	6 A	Max. switching capacity (reference value)	1,500 VA, 180 W
Max. switching voltage	250 VAC, 125 VDC		

Relays with forcibly guided contacts

Contact resistance	100 mΩ max. (The contact resistance was measured with 1 A at 5 VDC using the voltage-drop method.)	
Operating time ^{*1}	20 ms max.	
Response time ^{*1}	10 ms max. (The response time is the time it takes for the normally open contacts to open after the coil voltage is turned OFF.)	
Release time ^{*1}	20 ms max.	
Insulation resistance	100 MΩ min. (at 500 VDC) (The insulation resistance was measured with a 500 VDC megger at the same places that the dielectric strength was measured.)	
Dielectric strength ^{*2 *3}	Between coil contacts/different poles: 4,000 VAC, 50/60 Hz for 1 min (2,500 VAC between poles 3-4 in 4-pole Relays or poles 3-5, 4-6, and 5-6 in 6-pole Relays.) Between contacts of same polarity: 1,500 VAC, 50/60 Hz for 1 min	
Durability	Mechanical	10,000,000 operations min. (at approx. 36,000 operations/hr)
	Electrical	100,000 operations min. (at the rated load and approx. 1,800 operations/hr)
Min. permissible load ^{*4}	5 VDC, 1 mA (reference value)	
Ambient temperature ^{*5}	Operating: -40 to 85°C (with no icing or condensation)	
Ambient humidity	Operating: 35 to 85%	
Approved standards	EN61810-1 (IEC61810-1), EN50205, UL508, CSA22.2 No. 14	

^{*1} These times were measured at the rated voltage and an ambient temperature of 23°C. Contact bounce time is not included.

^{*2} Pole 3 refers to terminals 31-32 or 33-34, pole 4 refers to terminals 43-44, pole 5 refers to terminals 53-54, and pole 6 refers to terminals 63-64.

^{*3} When using a P7SA socket, the dielectric strength between coil contacts/different poles is 2,500 VAC, 50/60 Hz for 1 min.

^{*4} Min. permissible load is for a switching frequency of 300 operations/min.

^{*5} When operating at a temperature between 70°C and 85°C, reduce the rated carry current (6 A at 70°C or less) by 0.1 A for each degree above 70°C.

Note: The values listed above are initial values.

Please check Omron in the Internet for updated information on product reliability data and the SISTEMA libraries:
<http://industrial.omron.eu/safety>