

Programmable Terminal NA-series Software

User's Manual

NA5-15W101

NA5-12W101

NA5-9W001

NA5-7W001



© OMRON, 2014

All rights reserved. No part of this publication may be reproduced, stored in a retrieval system, or transmitted, in any form, or by any means, mechanical, electronic, photocopying, recording, or otherwise, without the prior written permission of OMRON.

No patent liability is assumed with respect to the use of the information contained herein. Moreover, because OMRON is constantly striving to improve its high-quality products, the information contained in this manual is subject to change without notice. Every precaution has been taken in the preparation of this manual. Nevertheless, OMRON assumes no responsibility for errors or omissions. Neither is any liability assumed for damages resulting from the use of the information contained in this publication.

Trademarks

- Sysmac and SYSMAC are trademarks or registered trademarks of OMRON Corporation in Japan and other countries for OMRON factory automation products.
- Windows, Windows XP, Windows Vista, Windows 7, Windows 8, Excel, and Visual Basic are registered trademarks of Microsoft Corporation in the USA and other countries.
- EtherCAT® is registered trademark and patented technology, licensed by Beckhoff Automation GmbH, Germany.
- ODVA, CIP, CompoNet, DeviceNet, and EtherNet/IP are trademarks of ODVA.
- The SD and SDHC logos are trademarks of SD-3C, LLC. 
- Portions of this software are copyright 2014 The FreeType Project (www.freetype.org). All rights reserved.

Other company names and product names in this document are the trademarks or registered trademarks of their respective companies.

Introduction

Thank you for purchasing an NA-series Programmable Terminal.

This manual contains information that is necessary to use the NA-series Programmable Terminal. Please read this manual and make sure you understand the functionality and performance of the NA-series Programmable Terminal before you attempt to use it in a control system.

Keep this manual in a safe place where it will be available for reference during operation.

Intended Audience

This manual is intended for the following personnel, who must also have knowledge of electrical systems (an electrical engineer or the equivalent).

- Personnel in charge of introducing FA systems.
- Personnel in charge of designing FA systems.
- Personnel in charge of installing and maintaining FA systems.
- Personnel in charge of managing FA systems and facilities.

Applicable Products

This manual covers the following products.

- NA-series Programmable Terminals

Relevant Manuals

The basic information required to use an NA-series PT is provided in the following three manuals.

- *NA-series Programmable Terminal Hardware User's Manual* (Cat. No. V117)
- *NA-series Programmable Terminal Software User's Manual* (Cat. No. V118)
- *NA-series Programmable Terminal Device Connection User's Manual* (Cat. No. V119)

Operations are performed from the Sysmac Studio Automation Software.

Refer to the *Sysmac Studio Version 1 Operation Manual* (Cat. No. W504) for information on the Sysmac Studio.

Other manuals are necessary for specific system configurations and applications.

The following manual is also available to walk you through installations and operations up to starting actual operation using simple examples.

Refer to it as required.

- *NA-series Programmable Terminal Startup Guide Manual* (Cat. No. V120)

Manual Structure

Page Structure and Markings

The following page structure is used in this manual.

Level 1 heading

Level 2 heading

Level 3 heading

Give the current headings.

Page tab

Gives the number of the main section.

Level 2 heading

Level 3 heading

A step in a procedure

Indicates a procedure.

Special information

Icons indicate precautions, additional information, or reference information.

Manual name

3 Installation and Wiring

3-3 Installing NA-series PTs

3-3-1 Installation in a Control Panel

Installation in a Control Panel

The NA-series PT is installed by embedding it in a control panel. Panel Mounting Brackets and a Phillips screwdriver are required to mount the NA-series PT. The required number of Panel Mounting Brackets are included with the NA-series PT.

Panel Mounting Bracket Phillips screwdriver

Use the following installation procedure.

1 Open a hole in which to embed the NA-series PT with the following dimensions and insert the NA-series PT from the front side of the panel.

Vertical

Horizontal

Recommended panel thickness: 1.6 to 6.0 mm

Model	Dimensions
NA5-15W□□□□	392 ^{+1/-0} × 268 ^{+1/-0} mm (horizontal × vertical)
NA5-12W□□□□	310 ^{+1/-0} × 221 ^{+1/-0} mm (horizontal × vertical)
NA5-9W□□□□	261 ^{+1/-0} × 166 ^{+1/-0} mm (horizontal × vertical)
NA5-7W□□□□	197 ^{+0.5/-0} × 141 ^{+0.5/-0} mm (horizontal × vertical)

Additional Information

You can use an NS-USBEXT-1M USB Relay Cable to extend the USB slave connector on the back panel of the NA-series PT to the front surface of a control panel. If you use the USB Relay Cable, open a hole with the following dimensions and install the Cable.

2 Attach the panel mounting brackets from the back of the panel as shown in the following figure. The number of mounting brackets depends on the size of the NA-series PT, as shown in the following table. Refer to Bracket Mounting Locations for Different NA-series PT Sizes on page 3-8, below.

Model	Number of Panel Mounting Brackets
NA5-15W□□□□	8 locations
NA5-12W□□□□	6 locations
NA5-9W□□□□	4 locations
NA5-7W□□□□	4 locations

Catch the brackets in the mounting holes in the NA-series PT, pull forward lightly, and then use a Phillips screwdriver to tighten the screws and secure the NA-series PT to the panel, which will be held between the mounting brackets and the NA-series PT.

3 - 5

NA Series Programmable Terminal Hardware User's Manual (V117)

Note This illustration is provided only as a sample. It may not literally appear in this manual.

Special Information

Special information in this manual is classified as follows:



Precautions for Safe Use

Precautions on what to do and what not to do to ensure safe usage of the product.



Precautions for Correct Use

Indicates precautions on what to do and what not to do to ensure proper operation and performance.



Additional Information

Additional information to read as required.

This information is provided to increase understanding or make operation easier.



Version Information

Information on differences in specifications and functionality with different versions is given.

Sections in this Manual

1	Introduction to the NA-series Programmable Terminals	10	Connecting to HMIs from External Devices	1	10
2	Basic Sysmac Studio Operations	11	Other Functions	2	11
3	HMI Configuration and Setup	A	Appendices	3	A
4	Creating the HMI Application	I	Index	4	I
5	Objects			5	
6	Connecting to the HMI			6	
7	Debugging			7	
8	Synchronizing Projects			8	
9	Reusing Objects			9	

CONTENTS

Introduction.....	1
Relevant Manuals.....	2
Manual Structure.....	3
Sections in this Manual.....	5
Terms and Conditions Agreement	11
Safety Precautions.....	13
Precautions for Safe Use	15
Precautions for Correct Use	18
Regulations and Standards	19
Related Manuals.....	21
Terminology.....	25
Revision History.....	26

Section 1 Introduction to the NA-series Programmable Terminals

1-1 NA-series Programmable Terminals.....	1-2
1-1-1 Features.....	1-2
1-2 How HMIs Operate.....	1-4
1-2-1 HMI Software Configuration.....	1-4
1-2-2 HMI Projects	1-4
1-2-3 Pages	1-4
1-2-4 Objects.....	1-5
1-2-5 Memory Specifications for Connected Devices	1-6
1-2-6 Events.....	1-7
1-2-7 Subroutines.....	1-8
1-2-8 Functions Shared by the Entire HMI Project.....	1-9
1-2-9 Data That Retained When Power Is Turned OFF.....	1-9
1-3 Operating Procedure for HMIs	1-10
1-3-1 Overall Procedure.....	1-10
1-3-2 Procedure Details	1-11

Section 2 Basic Sysmac Studio Operations

2-1 Parts of the Sysmac Studio Window	2-2
2-1-1 Application Window	2-2
2-2 Menu Command Structure.....	2-6
2-3 Basic Editing Operations.....	2-8
2-4 Sysmac Studio Settings and Operations	2-10
2-4-1 Setting Parameters.....	2-10
2-4-2 Programming	2-10
2-4-3 Library Functions	2-11

2-4-4	Operations for Debugging	2-11
2-4-5	Communications	2-11
2-4-6	Security Measures	2-11
2-4-7	Online Help	2-12
2-5	Basic Operations for HMI Projects.....	2-13
2-5-1	Creating a Project File from the Project Window	2-13
2-5-2	Adding an HMI to an Existing Project.....	2-14
2-5-3	Changing Devices.....	2-15

Section 3 HMI Configuration and Setup

3-1	Outline of Configurations and Setup.....	3-2
3-1-1	Connected Device Registration and Variable Mapping.....	3-2
3-2	Device References.....	3-3
3-2-1	Types of Connected Devices	3-3
3-2-2	Connected Devices in the Current Project.....	3-3
3-2-3	Registering External Connected Devices.....	3-4
3-3	Mapping Variables	3-7
3-3-1	Mapping Variables.....	3-7
3-3-2	Opening the Variable Mapping Tab Page and Tab Page Parts	3-7
3-3-3	Variable Mapping Methods.....	3-8
3-4	HMI Settings.....	3-10
3-4-1	HMI Settings.....	3-10
3-4-2	Device Settings	3-11
3-4-3	TCP/IP Settings.....	3-12
3-4-4	FTP Settings	3-13
3-4-5	NTP Settings.....	3-14
3-4-6	FINS Settings.....	3-15
3-4-7	VNC Settings.....	3-16
3-5	Security Settings	3-17
3-6	Language Settings	3-18
3-7	HMI Clock	3-19
3-8	Updating the HMI Name	3-20
3-9	Write Protecting the HMI.....	3-21
3-10	Clear All Memory	3-22
3-11	Resetting the HMI	3-23

Section 4 Creating the HMI Application

4-1	Registering Variables	4-2
4-1-1	Variables	4-2
4-1-2	Registering Global Variables	4-2
4-1-3	Registering External Variables	4-4
4-1-4	Attributes and Entry Methods for Global Variables	4-5
4-1-5	System-defined Variables	4-8
4-1-6	Subroutine Variables	4-10
4-2	Creating Pages	4-11
4-2-1	Displaying Pages	4-12
4-2-2	Registering Pages.....	4-12
4-2-3	Page Property Settings	4-14
4-2-4	Editing Pages.....	4-15
4-3	Setting Common Object Functions	4-18
4-3-1	Registering User Alarms	4-18
4-3-2	Registration for Data Logging	4-20

4-3-3	Registering Recipes.....	4-21
4-3-4	Setting Global Events and Corresponding Actions.....	4-22
4-3-5	Registering Global Subroutines.....	4-24
4-3-6	Setting Up Resources.....	4-25
4-3-7	Setting Up IAG Resources.....	4-26
4-4	Subroutines.....	4-27
4-4-1	Subroutine Execution.....	4-28
4-4-2	Precautions on Internal Processing.....	4-31
4-4-3	Code Editor.....	4-31
4-4-4	Differences in Language Specifications.....	4-31
4-5	Search and Replace.....	4-32
4-6	Building.....	4-33
4-6-1	Building.....	4-33
4-6-2	Build Operation.....	4-33
4-7	Offline Comparison.....	4-34

Section 5 Objects

5-1	Objects.....	5-2
5-1-1	Object List.....	5-2
5-1-2	Object Attributes.....	5-3
5-1-3	Using Objects.....	5-7
5-2	Examples of Using Objects.....	5-11
5-2-1	Displaying a PDF File.....	5-11
5-2-2	Displaying a User Alarm.....	5-13
5-2-3	Displaying a Trend Graph.....	5-15
5-2-4	Using a Recipe.....	5-17

Section 6 Connecting to the HMI

6-1	Introduction.....	6-2
6-2	Going Online with an HMI.....	6-3
6-2-1	Methods for Going Online with an HMI.....	6-3
6-2-2	Setting the Connection Method.....	6-4
6-2-3	Online Connection.....	6-5
6-2-4	Going Online after Checking the Connection Method.....	6-6
6-2-5	Going Offline.....	6-6
6-2-6	Confirming Serial IDs.....	6-6

Section 7 Debugging

7-1	HMI Debugging Functions.....	7-2
7-1-1	Watch Tab Page.....	7-2
7-1-2	Breakpoints.....	7-3
7-1-3	Step Execution.....	7-4
7-1-4	Offline Debugging with Only the HMI Simulator.....	7-6
7-1-5	Offline Debugging with the Controller Simulator.....	7-7

Section 8 Synchronizing Projects

8-1	Synchronizing Projects.....	8-2
8-2	Using Storage Media for Synchronization.....	8-5

Section 9 Reusing Objects

9-1 Reusing Objects	9-2
9-2 IAGs	9-3
9-2-1 Differences when an IAG Project Is Selected	9-3
9-2-2 Creating an IAG	9-6
9-2-3 Using IAGs.....	9-9
9-3 Custom Objects	9-11
9-3-1 Objects That You Can Register as Custom Objects	9-11
9-3-2 Creating Custom Objects	9-11
9-3-3 Deleting Custom Objects	9-14
9-3-4 Using Custom Objects	9-15

Section 10 Connecting to HMIs from External Devices

10-1 Accessing an HMI from an External Device	10-2
10-1-1 VNC.....	10-2
10-1-2 FTP	10-3

Section 11 Other Functions

11-1 Sysmac Studio Option Settings	11-2
---	-------------

Appendices

A-1 Events and Actions	A-2
A-2 Supported Formats.....	A-4
A-3 Differences between the Physical HMI and Simulator	A-5

Index

Terms and Conditions Agreement

Warranty, Limitations of Liability

Warranties

● Exclusive Warranty

Omron's exclusive warranty is that the Products will be free from defects in materials and workmanship for a period of twelve months from the date of sale by Omron (or such other period expressed in writing by Omron). Omron disclaims all other warranties, express or implied.

● Limitations

OMRON MAKES NO WARRANTY OR REPRESENTATION, EXPRESS OR IMPLIED, ABOUT NON-INFRINGEMENT, MERCHANTABILITY OR FITNESS FOR A PARTICULAR PURPOSE OF THE PRODUCTS. BUYER ACKNOWLEDGES THAT IT ALONE HAS DETERMINED THAT THE PRODUCTS WILL SUITABLY MEET THE REQUIREMENTS OF THEIR INTENDED USE.

Omron further disclaims all warranties and responsibility of any type for claims or expenses based on infringement by the Products or otherwise of any intellectual property right.

● Buyer Remedy

Omron's sole obligation hereunder shall be, at Omron's election, to (i) replace (in the form originally shipped with Buyer responsible for labor charges for removal or replacement thereof) the non-complying Product, (ii) repair the non-complying Product, or (iii) repay or credit Buyer an amount equal to the purchase price of the non-complying Product; provided that in no event shall Omron be responsible for warranty, repair, indemnity or any other claims or expenses regarding the Products unless Omron's analysis confirms that the Products were properly handled, stored, installed and maintained and not subject to contamination, abuse, misuse or inappropriate modification. Return of any Products by Buyer must be approved in writing by Omron before shipment. Omron Companies shall not be liable for the suitability or unsuitability or the results from the use of Products in combination with any electrical or electronic components, circuits, system assemblies or any other materials or substances or environments. Any advice, recommendations or information given orally or in writing, are not to be construed as an amendment or addition to the above warranty.

See <http://www.omron.com/global/> or contact your Omron representative for published information.

Limitation on Liability; Etc

OMRON COMPANIES SHALL NOT BE LIABLE FOR SPECIAL, INDIRECT, INCIDENTAL, OR CONSEQUENTIAL DAMAGES, LOSS OF PROFITS OR PRODUCTION OR COMMERCIAL LOSS IN ANY WAY CONNECTED WITH THE PRODUCTS, WHETHER SUCH CLAIM IS BASED IN CONTRACT, WARRANTY, NEGLIGENCE OR STRICT LIABILITY.

Further, in no event shall liability of Omron Companies exceed the individual price of the Product on which liability is asserted.

Application Considerations

Suitability of Use

Omron Companies shall not be responsible for conformity with any standards, codes or regulations which apply to the combination of the Product in the Buyer's application or use of the Product. At Buyer's request, Omron will provide applicable third party certification documents identifying ratings and limitations of use which apply to the Product. This information by itself is not sufficient for a complete determination of the suitability of the Product in combination with the end product, machine, system, or other application or use. Buyer shall be solely responsible for determining appropriateness of the particular Product with respect to Buyer's application, product or system. Buyer shall take application responsibility in all cases.

NEVER USE THE PRODUCT FOR AN APPLICATION INVOLVING SERIOUS RISK TO LIFE OR PROPERTY WITHOUT ENSURING THAT THE SYSTEM AS A WHOLE HAS BEEN DESIGNED TO ADDRESS THE RISKS, AND THAT THE OMRON PRODUCT(S) IS PROPERLY RATED AND INSTALLED FOR THE INTENDED USE WITHIN THE OVERALL EQUIPMENT OR SYSTEM.

Programmable Products

Omron Companies shall not be responsible for the user's programming of a programmable Product, or any consequence thereof.

Disclaimers

Performance Data

Data presented in Omron Company websites, catalogs and other materials is provided as a guide for the user in determining suitability and does not constitute a warranty. It may represent the result of Omron's test conditions, and the user must correlate it to actual application requirements. Actual performance is subject to the Omron's Warranty and Limitations of Liability.

Change in Specifications

Product specifications and accessories may be changed at any time based on improvements and other reasons. It is our practice to change part numbers when published ratings or features are changed, or when significant construction changes are made. However, some specifications of the Product may be changed without any notice. When in doubt, special part numbers may be assigned to fix or establish key specifications for your application. Please consult with your Omron's representative at any time to confirm actual specifications of purchased Product.

Errors and Omissions

Information presented by Omron Companies has been checked and is believed to be accurate; however, no responsibility is assumed for clerical, typographical or proofreading errors or omissions.

Safety Precautions

Definition of Precautionary Information

The following notation is used in this manual to provide precautions required to ensure safe usage of the NA-series Programmable Terminal. The safety precautions that are provided are extremely important to safety. Always read and heed the information provided in all safety precautions.

The following notation is used.



WARNING

Indicates a potentially hazardous situation which, if not avoided, could result in mild or moderate injury or at the worst, serious injury or death. Additionally, there may be severe property damage.



Caution

Indicates a potentially hazardous situation which, if not avoided, may result in minor or moderate injury, or property damage.



Precautions for Safe Use

Indicates precautions on what to do and what not to do to ensure safe usage of the product.



Precautions for Correct Use

Indicates precautions on what to do and what not to do to ensure proper operation and performance.

Symbols



The circle and slash symbol indicates operations that you must not do.
The specific operation is shown in the circle and explained in text.
This example indicates prohibiting disassembly.



The triangle symbol indicates precautions (including warnings).
The specific operation is shown in the triangle and explained in text.
This example indicates a general precaution.

Warnings



WARNING

Do not attempt to take the NA Unit apart and do not touch the product inside while the power is being supplied. Otherwise it may result in electric shock.



Always ensure that the personnel in charge confirm that installation, inspection, and maintenance were properly performed for the NA Unit. "Personnel in charge" refers to individuals qualified and responsible for ensuring safety during machine design, installation, operation, maintenance, and disposal.



Ensure that installation and post-installation checks are performed by personnel in charge who possess a thorough understanding of the machinery to be installed.



Do not use the input functions such as the touch panel or function keys of the NA Unit, in applications that involve human life, in applications that may result in serious injury, or for emergency stop switches.

Do not attempt to disassemble, repair, or modify the NA Unit. It may cause NA Unit to lose its safety function.



Never press two points or more on the touch panel of the NA Unit at a time. Touching two points or more interrupts normal touch panel operations.

Precautions for Safe Use

- When unpacking the NA Unit, check carefully for any external scratches or other damages. Also, shake the NA Unit gently and check for any abnormal sound.
- The NA Unit must be installed in a control panel.
- The mounting panel must be between 1.6 and 6.0 mm thick. Tighten the Mounting Brackets evenly to a torque of between 0.5 and 0.6 N·m to maintain water and dust resistance. If the tightening torque exceeds the specified value, or the tightening is not even, deformation of the front panel may occur. What is more, make sure the panel is not dirty or warped and that it is strong enough to hold the NA Unit.
- Do not let metal particles enter the NA Unit when preparing the panel.
- Turn OFF the power supply before connecting or disconnecting cables.
- Periodically check the installation conditions in applications where the NA Unit is subject to contact with oil or water.
- Be certain to use the cables with lock mechanism such as serial cable or the Ethernet cable after confirming if it is securely locked.
- Do not touch the packaging part of the circuit board with your bare hands. Discharge any static electricity from your body before handling the board.
- Do not use volatile solvents such as benzene and thinners or chemical cloths.
- Water and oil resistance will be lost if the front sheet is torn or is peeling off. Do not use the NA Unit, if the front sheet is torn or is peeling off.
- As the rubber packing will deteriorate, shrink, or harden depending on the operating environment, periodical inspection is necessary.
- Confirm the safety of the system before turning ON or OFF the power supply, or pressing the reset switch.
- The whole system may stop depending on how the power supply is turned ON or OFF. Turn ON/OFF the power supply according to the specified procedure.
- Operate DIP switch according to the following way.

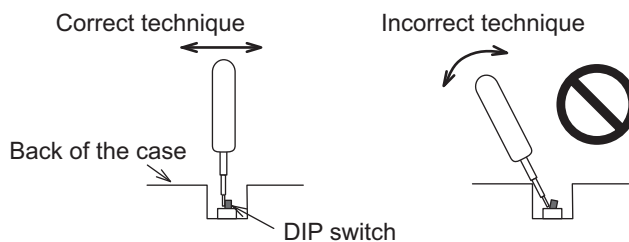

The DIP switch may break if it is levered with a tool against the case as shown in the figure.

- Once the DIP switch settings are changed, reset by pressing the reset switch, or restart the power supply.
- Initialize the project, after confirming that existing project is backed up at the Sysmac Studio.
- When changing the password, do not reset or turn OFF the power supply until the writing is completed. A failure to store the password may cause the project to fail to function.
- While uploading or downloading a project or a system program, do not perform the operations as follows. Such operations may corrupt the project or the system program:
 - Turning OFF the power supply of the NA Unit
 - Resetting the NA Unit.
 - Removing the USB devices or SD card.
 - Disconnecting the cable between a support tool and the NA Unit.
- Do not connect an AC power supply to the DC power terminals.
- Do not perform a dielectric strength test.

- Use a DC power with a slight voltage fluctuation and that will provide a stable output even if the input is momentarily interrupted for 10 ms. Also use the one with reinforced insulation or double insulation. Rated Power Supply Voltage: 24VDC (Allowable range 19.2 to 28.8VDC)
- Use a power cable with AWG#12 to #22 thick (0.35mm² to 3.31mm²). Peel the coating 7mm length and tighten the terminal screw with the torque in the range of 0.5 to 0.6 N·m. Also confirm if the terminal screw is tightened appropriately.
- To prevent malfunctions caused by noise, ground the NA Unit correctly.
- Do not use any battery if strong impact is applied to it (e.g. by dropping on the floor) because such a battery may cause a leakage.
- Confirm the type of the battery to install the battery properly.
- Apply power for at least five minutes before changing the battery. Mount a new battery within five minutes after turning OFF the power supply. If power is not supplied for at least five minutes, the clock data may be lost. Check the clock data after changing the battery.
- Do not dismantle a battery nor let it short-circuit.
- Do not apply an impact with the lithium battery, charge it, dispose it into a fire, or heat it. Doing either of them may cause an ignition or a bursting.
- Dispose of the NA Units and batteries according to local ordinances as they apply.



- The following precaution must be displayed on all products containing lithium primary batteries with a perchlorate content of 6ppb or higher when exporting them to or shipping them through California, USA.

Perchlorate Material - special handling may apply.

See www.dtsc.ca.gov/hazardouswaste/perchlorate

The NA-Series contains a lithium primary battery with a perchlorate content of 6ppb or higher. When exporting a product containing the NA-Series to or shipping such a product through California, USA, label all packing and shipping containers appropriately.

- Do not connect the USB devices in the environment subject to the strong vibration.
- Do not connect USB devices which are not allowed to connect to NA Unit.
- Start actual system application only after checking normal operation of the system including storage devices such as USB memory and SD card.
- When connecting peripheral devices which do not meet the performance level of the NA Unit for noise and static electricity, ensure sufficient countermeasures against noise and static electricity during installation of the peripheral devices to the NA Unit.
- Do not carry out the following operations when accessing USB devices or SD card:
 - Turning OFF the power supply of the NA Unit
 - Press the Reset switch of the NA Unit
 - Pull out the USB devices or SD card
- When using the No. 6 pin of the serial port connector for a voltage of DC+5V, make sure the supply equipment's current capacity is below 250mA before using it. The DC+5V voltage output of the NA Unit is +5V±5%, and the maximum current is 250mA.
- To ensure the system's safety, make sure to incorporate a program that call periodically signals during the operation at connected device side and can confirm the normal functionality of the NA Unit before running the system.
- Start actual system application only after sufficiently checking project, subroutine and the operation of the program at the connected device side.
- To use numeric input functions safely, always make maximum and minimum limit settings.
- Do not press the touch panel with a force greater than 30 N.
- Do not use hard or pointed objects to operate or scrub the screen, otherwise the surface of the screen may be damaged.

- The deterioration over time may cause the touch points to move on the touch panel. Calibrate the touch panel periodically.
- A touch position detection error of approximately 20 pixels may occur due to the precision of the touch panel. Always take this into account when positioning objects on the panel so adjoining objects will not be activated by mistake.
- Confirm the safety of the system before pressing the touch panel.
- Do not accidentally press the touch panel when the backlight is not lit or when the display does not appear or is too dark to identify visually.
- You can change the brightness by changing the setting such as in the system menu or by downloading project.
If the brightness is set to very dark, it causes flickering or unreadable screen. Additionally, the brightness can be restored by transferring the project again after setting the property of the brightness appropriately.
In a case of the applications where end users can control the brightness, create the applications so as keeping on operations by such as assigning the function which restores the brightness to one of function keys, if necessary.
- Signals from the touch panel may not be entered if the touch panel is pressed consecutively at high speed. Make sure to go on the next operation after confirming that the NA Unit has detected the input of the touch panel.
- The function keys have the restrictions as follows:
 - Using both anti-reflection sheet and protective cover interrupts the normal function key operation. Do not use them together.
 - When you use gloves or others, the function keys may not work correctly depending on the material and thickness of the gloves. Take actual conditions of the gloves usage into considerations prior to the system startup to perform the confirmation.
 - The function keys do not work when covered with water. Remove the water completely before use.

Precautions for Correct Use

- **Do not install or store the NA Unit in any of the following locations:**
 - Locations subject to severe changes in temperature
 - Locations subject to temperatures or humidity outside the range specified in the specifications
 - Locations subject to condensation as the result of high humidity
 - Locations subject to corrosive or flammable gases
 - Locations subject to strong shock or vibration
 - Locations outdoors subject to direct wind and rain
 - Locations subject to strong ultraviolet light
 - Locations subject to dust
 - Locations subject to direct sunlight
 - Locations subject to splashing oil or chemicals

- **Take appropriate and sufficient countermeasures when installing systems in the following locations:**
 - Locations subject to static electricity or other forms of noise
 - Locations subject to strong electric field or magnetic field
 - Locations close to power supply lines
 - Locations subject to possible exposure to radioactivity

Regulations and Standards

Conformance to EC Directives

Applicable Directives

- EMC Directive

Concepts

● EMC Directive

OMRON devices that comply with EC Directives also conform to the related EMC standards so that they can be more easily built into other devices or the overall machine. The actual products have been checked for conformity to EMC standards.*

Whether the products conform to the standards in the system used by the customer, however, must be checked by the customer. EMC-related performance of the OMRON devices that comply with EC Directives will vary depending on the configuration, wiring, and other conditions of the equipment or control panel on which the OMRON devices are installed. The customer must, therefore, perform the final check to confirm that devices and the overall machine conform to EMC standards.

- * Applicable EMC (Electromagnetic Compatibility) standards are as follows:
EMS (Electromagnetic Susceptibility): EN 61131-2:2007
EMI (Electromagnetic Interference): EN 61131-2:2007

● Conformance to EC Directives

The NA-series PTs comply with EC Directives. To ensure that the machine or device in which the NA-series PT is used complies with EC Directives, the NA-series PT must be installed as follows:

- The NA Unit must be installed within a control panel.
- You must use reinforced insulation or double insulation for the DC power supplies connected to the NA Unit.
- NA-series PTs that comply with EC Directives also conform to the Common Emission Standard (EN 61000-6-4). Radiated emission characteristics (10-m regulations) may vary depending on the configuration of the control panel used, other devices connected to the control panel, wiring, and other conditions.
You must therefore confirm that the overall machine or equipment complies with EC Directives.
- This is a Class A product (for industrial environments). In a residential environment, it may cause radio interference, in which case the user may be required to take appropriate measures.

Conformance to KC Standards

Observe the following precaution if you use NA-series PTs in Korea.

A 급 기기 (업무용 방송통신기자재)

이 기기는 업무용(A 급) 전자파적합기기로서 판매자 또는 사용자는 이 점을 주의하시기 바라며, 가정외의 지역에서 사용하는 것을 목적으로 합니다.

Class A Device (Broadcasting Communications Device for Business Use)

This device obtained EMC registration for office use (Class A), and it is intended to be used in places other than homes. Sellers and/or users need to take note of this.

Related Manuals

The following manuals are related to the NA-series PTs. Use these manuals for reference.

Manual name	Cat. No.	Models	Applications	Description
NA-series Programmable Terminal Hardware User's Manual	V117	NA5-□W□□□□	Learning the specifications and settings required to install an NA-series PT and connect peripheral devices.	Information is provided on NA-series PT specifications, part names, installation procedures, and procedures to connect an NA Unit to peripheral devices. Information is also provided on maintenance after operation and troubleshooting.
NA-series Programmable Terminal Software User's Manual	V118	NA5-□W□□□□	Learning about NA-series PT pages and object functions.	NA-series PT pages and object functions are described.
NA-series Programmable Terminal Device Connection User's Manual	V119	NA5-□W□□□□	Learning the specifications required to connect devices to an NA-series PT.	Information is provided on connection procedures and setting procedures to connect an NA-series PT to a Controller or other device.
NA-series Programmable Terminal Startup Guide	V120	NA5-□W□□□□	Learning in concrete terms information required to install and start the operation of an NA-series PT.	The part names and installation procedures are described followed by page creation and transfer procedures with the Sysmac Studio. Also operation, maintenance, and inspection procedures after the project is transferred are described. Sample screen captures are provided as examples.
NJ-series CPU Unit Hardware User's Manual	W500	NJ501-□□□□ NJ301-□□□□	Learning the basic specifications of the NJ-series CPU Units, including introductory information, designing, installation, and maintenance. Mainly hardware information is provided.	An introduction to the entire NJ-series system is provided along with the following information on a Controller built with a CPU Unit. <ul style="list-style-type: none"> • Features and system configuration • Introduction • Part names and functions • General specifications • Installation and wiring • Inspection and maintenance Use this manual together with the <i>NJ-series CPU Unit Software User's Manual</i> (Cat. No. W501).

Manual name	Cat. No.	Models	Applications	Description
NJ-series CPU Unit Software User's Manual	W501	NJ501-□□□□ NJ301-□□□□	Learning how to program and set up an NJ-series CPU Unit. Mainly software information is provided.	Provides the following information on a Controller built with an NJ-series CPU Unit. <ul style="list-style-type: none"> • CPU Unit operation • CPU Unit features • Initial settings • Programming based on IEC 61131-3 language specifications Use this manual together with the <i>NJ-series CPU Unit Hardware User's Manual</i> (Cat. No. W500).
CJ Series Programmable Controllers Operation Manual	W393	CJ1H-CPU□□H-R CJ1G/H-CPU□□H CJ1G-CPU□□P CJ1M-CPU□□ CJ1G-CPU□□	Learning the basic specifications of the CJ-series PLCs, including introductory information, designing, installation, and maintenance.	The following information is provided on a CJ-series PLC. <ul style="list-style-type: none"> • Introduction and features • System configuration design • Installation and wiring • I/O memory allocation • Troubleshooting Use this manual together with the <i>Programming Manual</i> (Cat. No. W394).
CS/CJ/NSJ Series Programmable Controllers Operation Manual	W394	CS1G/H-CPU□□H CS1G/H-CPU□□-V1 CS1D-CPU□□H CS1D-CPU□□S CJ1H-CPU□□H-R CJ1G/H-CPU□□H CJ1G-CPU□□P CJ1M-CPU□□ CJ1G-CPU□□ NSJ□-□□□□(B)-G5D NSJ□-□□□□(B)-M3D	Learning about the functions of the CS/CJ-series and NSJ-series PLCs.	The following information is provided on a CS/CJ-series or NSJ-series PLC. <ul style="list-style-type: none"> • Programming • Master function • File memory • Other functions Use this manual together with the <i>Operation Manual</i> (CS-series PLCs: W339, CJ-series PLCs: W393).
CS/CJ/NJ-series Instructions Reference Manual	W340	CS1□-CPU-□□□-□□ CJ1□-CPU-□□□-□□□ CJ2H-CPU-□□□-□□□ NSJ□□-□□□□□-□□□	Learning detailed information on programming instructions.	Instructions are described in detail. When programming, use this manual together with the <i>Operation Manual</i> (CS-series PLCs: W339, CJ-series PLCs: W393) and the <i>Programming Manual</i> (W394).
CS/CJ Series Programming Consoles Operation Manual	W341	CQM1H-PRO01 CQM1-PRO01 C200H-PRO27 +CS1W-KS001	Learning the operating procedures of the Programming Consoles.	The operating procedures of the Programming Consoles are described. When programming, use this manual together with the <i>Operation Manual</i> (CS-series PLCs: W339, CJ-series PLCs: W393), the <i>Programming Manual</i> (W394), and the <i>Instructions Reference Manual</i> (W340).

Manual name	Cat. No.	Models	Applications	Description
CS/CJ/NSJ Series Communications Commands Reference Manual	W342	CS1G/H-CPU□□H CS1G/H-CPU□□-V1 CS1D-CPU□□H CS1D-CPU□□S CS1W-SCU□□-V1 CS1W-SCB□□-V1 CJ1G/H-CPU□□H CJ1G-CPU□□P CJ1M-CPU□□ CJ1G-CPU□□ CJ1W-SCU□□-V1	Learning detailed specifications on the communications instructions addressed to CS/CJ-series CPU Units and NSJ-series PLCs.	1) C-mode commands and 2) FINS commands are described in detail. Refer to this manual for information on communications commands (C-mode commands and FINS commands) addressed to CPU Units. Note This manual describes communications commands that are addressed to a CPU Unit. The communications path is not relevant. (The communications commands can be sent through the serial communications port of the CPU Unit, the communications port of a Serial Communications Board/Unit, or a communications port on another Communications Unit.)
CJ-series CJ2 CPU Unit Hardware User's Manual	W472	CJ2H-CPU6□-EIP CJ2H-CPU6□ CJ2M-CPU□□	Learning the hardware specifications of CJ2 CPU Units.	The following information is provided on a CJ2 CPU Unit. <ul style="list-style-type: none"> • Introduction and features • Basic system configuration • Part names and functions • Installation and setting procedures • Troubleshooting Use this manual together with the <i>Software User's Manual</i> (Cat. No. W473).
CJ-series CJ2 CPU Unit Software User's Manual	W473	CJ2H-CPU6□-EIP CJ2H-CPU6□ CJ2M-CPU□□	Learning the software specifications of CJ2 CPU Units.	The following information is provided on a CJ2 CPU Unit. <ul style="list-style-type: none"> • CPU Unit operation • Internal memory • Programming • Settings • Functions built into the CPU Unit Use this manual together with the <i>Hardware User's Manual</i> (Cat. No. W472).
Ethernet Units Operation Manual Construction of Networks	W420	CS1W-ETN21 CJ1W-ETN21	Learning how to use an Ethernet Unit.	Information is provided on the Ethernet Units. Information is provided on the basic setup and FINS communications. Refer to the <i>Communications Commands Reference Manual</i> (Cat. No. W342) for details on FINS commands that can be sent to CS/CJ-series CPU Units when using the FINS communications service.

Manual name	Cat. No.	Models	Applications	Description
Ethernet Units Operation Manual Construction of Applications	W421	CS1W-ETN21 CJ1W-ETN21	Learning how to use an Ethernet Unit.	Information is provided on constructing host applications, including functions for sending/receiving mail, socket service, automatic clock adjustment, FTP server functions, and FINS communications.
CS/CJ-series EtherNet/IP™ Units Operation Manual	W465	CJ2H-CPU6□-EIP CJ2M-CPU3□ CS1W-EIP21 CJ1W-EIP21	Learning how to use the built-in EtherNet/IP port of the CJ2 CPU Units.	Information is provided on the built-in EtherNet/IP port and EtherNet/IP Units. Basic settings, tag data links, FINS communications, and other functions are described.
Sysmac Studio Version 1 Operation Manual	W504	SYSMAC-SE2□□□	Learning about the operating procedures and functions of the Sysmac Studio.	The operating procedures of the Sysmac Studio are described.
CX-Programmer Operation Manual	W446	CXONE-AL□□C-V4 CXONE-AL□□D-V4	Learning about the CX-Programmer except for information on function blocks, ST programming, and SFC programming.	The operating procedures of the CX-Programmer are described.

Terminology

Term	Description
HMI	A general term for interface devices that indicates both hardware and software elements. In this manual, "HMI" refers to an OMRON Sysmac-brand product unless otherwise specified.
PT	The hardware elements of the HMI.
NA Series	The NA Series of Programmable Terminals and peripheral devices.
HMI Project	A Sysmac Studio project for an HMI.
NA Unit	An NA-series Programmable Terminal.
Download	Transferring data from the Sysmac Studio to an HMI.
IAG collection	When you provide IAGs, you provide them as IAG collections. IAGs are also imported as IAG collections. An IAG collection contains one or more IAGs.

Revision History

A manual revision code appears as a suffix to the catalog number on the front and back covers of the manual.

Cat. No. V118-E1-01

↑
Revision code

Revision code	Date	Revised content
01	June 2014	Original production

1

Introduction to the NA-series Programmable Terminals

This section describes the features, basic system configuration, specifications, and overall operating procedure of the NA-series Programmable Terminals.

1-1 NA-series Programmable Terminals	1-2
1-1-1 Features	1-2
1-2 How HMIs Operate	1-4
1-2-1 HMI Software Configuration	1-4
1-2-2 HMI Projects	1-4
1-2-3 Pages	1-4
1-2-4 Objects	1-5
1-2-5 Memory Specifications for Connected Devices	1-6
1-2-6 Events	1-7
1-2-7 Subroutines	1-8
1-2-8 Functions Shared by the Entire HMI Project	1-9
1-3 Operating Procedure for HMIs	1-10
1-3-1 Overall Procedure	1-10
1-3-2 Procedure Details	1-11

1-1 NA-series Programmable Terminals

The NA-series Programmable Terminals represent the next generation of HMIs for industrial applications. They display information on FA manufacturing sites and function as control interfaces while providing safety, reliability, and maintainability. They provide all of the functions of traditional programmable terminals with a clearer, easy-to-use interface.

OMRON offers the new Sysmac Series of control devices designed with unified communications specifications and user interface specifications.

The NA-series Programmable Terminals are Sysmac devices that you can use together with the NJ-series Machine Automation Controllers and the Sysmac Studio Automation Software to achieve optimum functionality and ease of operation.

If you connect an NA-series Programmable Terminal to an NJ-series Controller, all you have to do to specify memory in the Controller is to specify the Controller variables for the objects on the Programmable Terminal screens. This allows you to create screens without being concerned with the memory map of the Controller.

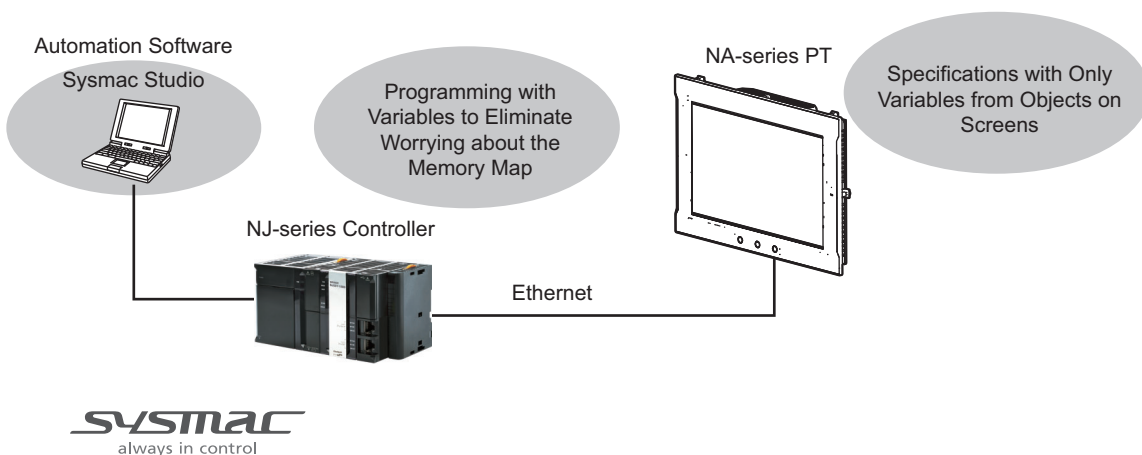

1-1-1 Features

Hardware Features

- **High-resolution Display Panels**

High-resolution display panels are used to more clearly display large amounts of information than was possible with previous OMRON products.

- **Two Ethernet Ports (Standard Feature)**

You can use both Ethernet ports to separate the segment attached to control devices from the segment attached to maintenance devices. Access is possible from both segments at the same time.

You can connect the following devices.

- NJ-series Controllers
- PLCs
- Computers
- Sysmac Studio

- **Standard-feature SD Memory Card Slot**

You can use an SD Memory Card inserted in the NA Unit to automatically transfer the project you created on the Sysmac Studio to the NA Unit, to update the system program in the NA Unit, or to save the log data from the NA Unit.

Software Features

- **Specifications with Variables for Superior Reusability**

If you connect to an NJ-series Controller, all you have to do to specify memory in the Controller is to specify the Controller variables. This allows you to create objects that are not dependent on specific devices or memory maps. This in turn makes the objects much more reusable than they were with previous PTs.

- **Program with Visual Basic**

You can use Microsoft's Visual Basic to program advanced functions that you cannot achieve with standard objects.

- **A Wealth of Security Features**

The many security features of the NA-series PTs include operation authority settings and execution restrictions with IDs.

- **Use the Integrated Development Environment of Sysmac Studio Automation Software**

You use the Sysmac Studio to create applications for the NA-series Programmable Terminals.

The Sysmac Studio provides an integrated development environment that covers not only the NA-series Programmable Terminal, but also the Controller and devices on EtherCAT as well.

You can use consistent procedures for all devices regardless of differences in the devices. The Sysmac Studio supports all phases of Controller application, from page creation and sequence design through debugging, simulations, commissioning, and changes during operation.

- **A Wealth of Simulation Features**

You can perform simulations using a virtual HMI on the Sysmac Studio. And you can also perform online debugging with a virtual NJ-series Controller.

1-2 How HMIs Operate

This section describes how the HMI operates.

1-2-1 HMI Software Configuration

An HMI consists of the following software.

- System Program

The system program is required to start the HMI and execute the runtime. For details, refer to *NA-series Programmable Terminal Hardware User's Manual (V117)*.

- Runtime

The runtime is the middleware that executes the project. The runtime is started by the system program and it manages execution of the project.

- Project

You use the Sysmac Studio to create your applications. The applications are executed on the runtime.

1-2-2 HMI Projects

An HMI project contains mainly the following data.

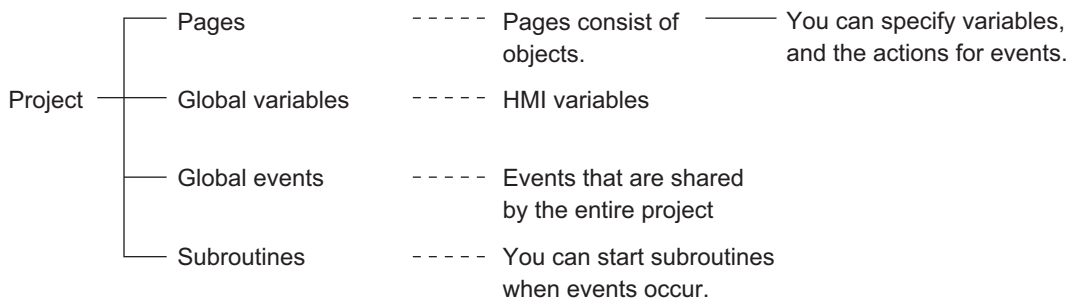

In addition, there is data that is shared by the entire project, such as user alarms, data logging, recipes, and resources.

1-2-3 Pages

One HMI screen is called a page.

There are the following two types of pages.

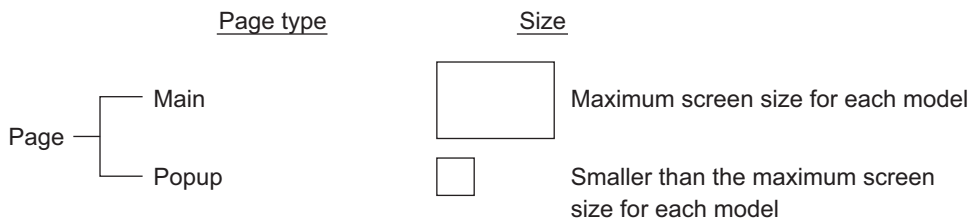

You paste objects on the pages.

1-2-4 Objects

The objects that you paste on HMI pages consist of the following three elements.

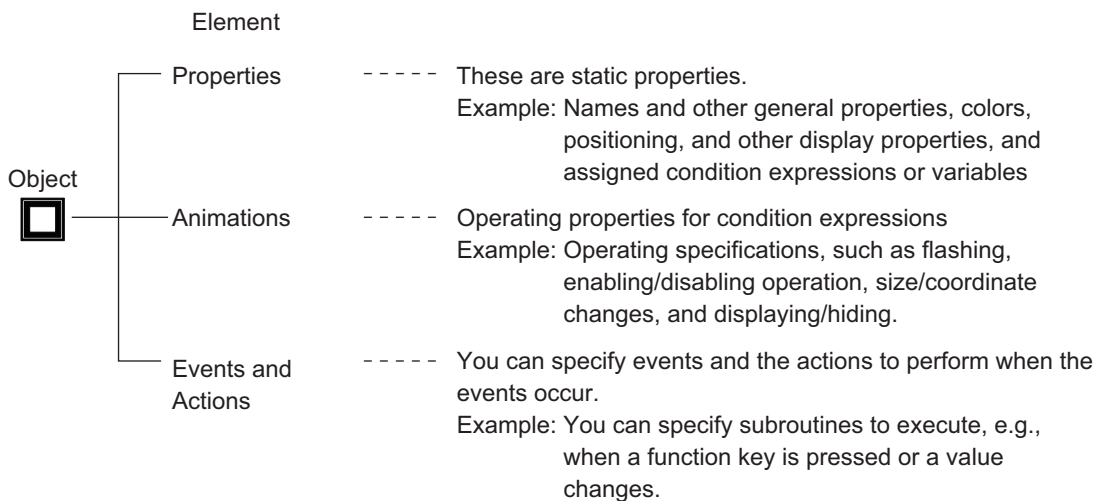

1-2-5 Memory Specifications for Connected Devices

Overview

You use HMI global variables to specify memory in a Controller or PLC.

You assign HMI global variables to connected device variables in advance to map them.

- 1) Variables for connected devices are registered to device variables in the HMI project with one of the following methods.
 - a) Variables for connected devices that are registered in the same project are registered automatically.
 - b) You can copy and paste variables from another project using the clipboard.
 - c) You can import variables from the external connected device.
- 2) Devices variables are assigned to HMI global variables.
- 3) The assigned HMI global variables are specified in the properties of the objects.
- 4) Then, you transfer the project that you created to the HMI.

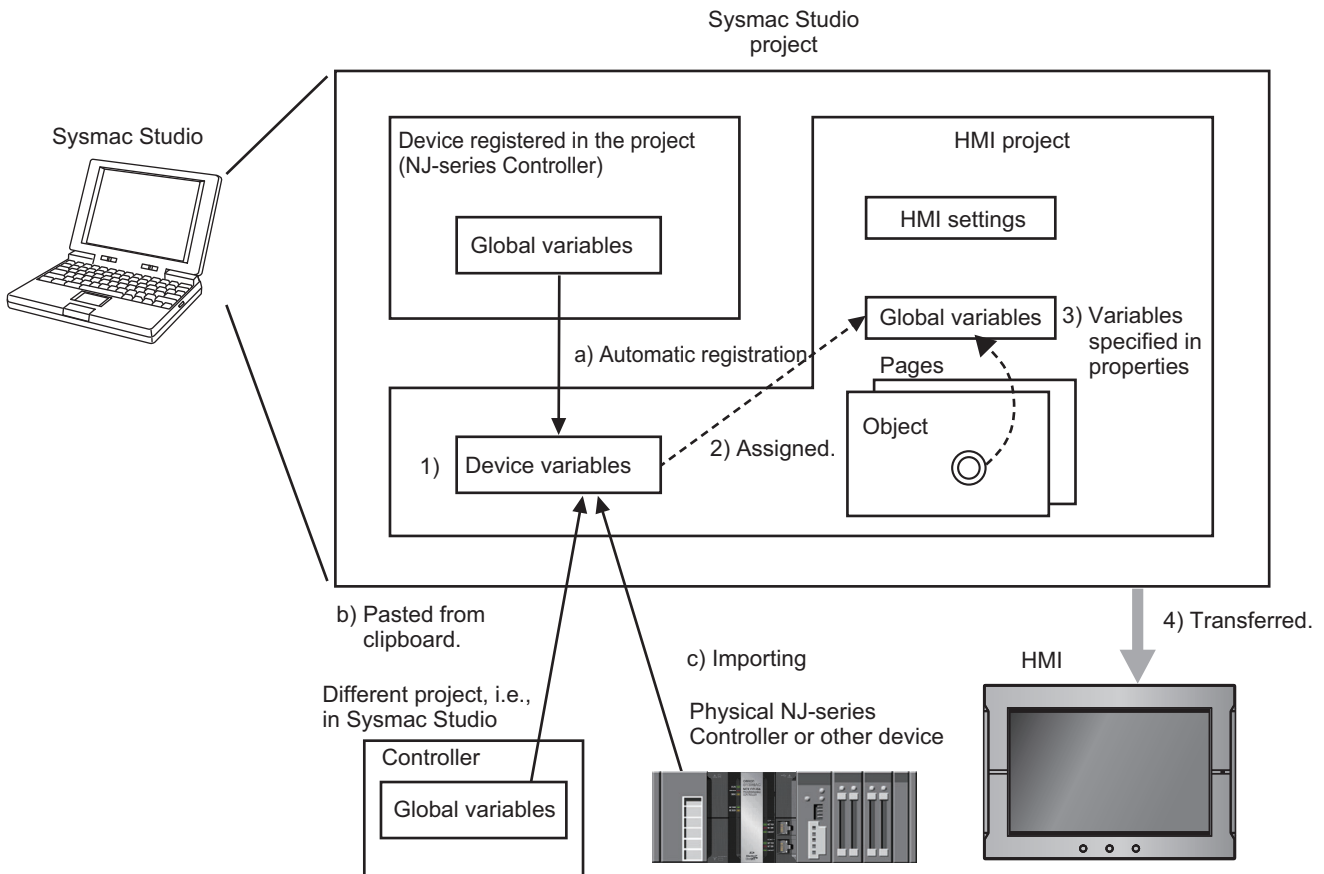

Refer to 4-1 Registering Variables on page 4-2 for the details on HMI variables.

1-2-6 Events

Events are triggers that activate actions.*1

*1. Actions are various operations that can be directly assigned to events.

Events occur when the common page status or object status meets certain conditions.

Events are classified into three groups as shown below.

	<u>Group</u>	<u>Description</u>
Events	Global events	Events that occur for shared project status.
	Page and object events	Events that occur for specific page or object status.
	User alarm events	Events that occur for user alarm status.

1-2-7 Subroutines

You can execute user-created subroutines in the HMI based on the following three types of conditions.

- When global events occur
- When events occur on pages or for objects
- When user alarm events occur

There are two types of subroutines that you can create.

- Global Subroutines
You create these subroutines under the global subroutine item of the HMI project.
- Page Subroutines
You create these subroutines with the page code editor.

You can use Visual Basic to write both the global subroutines and the page subroutines.

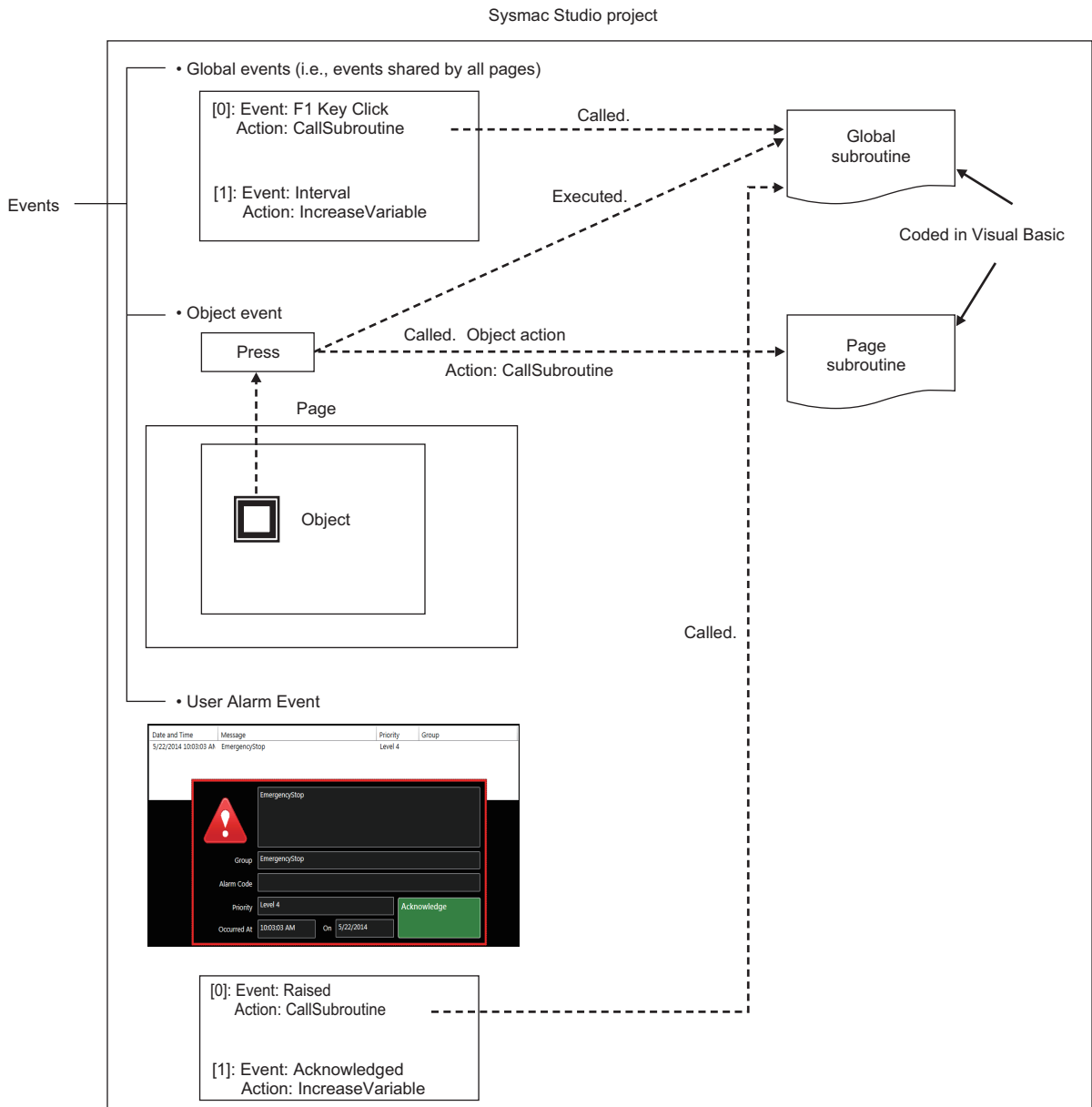

- You can call a global subroutine by executing the CallSubroutine action when a global event occurs.

- You can call a global subroutine or page subroutine by executing the CallSubroutine action when an event occurs on the page or for an object.
- You can call a global subroutine by executing the CallSubroutine action when a user alarm event occurs.

You can also call a global subroutine from another global subroutine or a page subroutine.

1-2-8 Functions Shared by the Entire HMI Project

In addition to global events, the following functions are shared by the entire HMI project.

Alarms

Alarms notify the user when certain conditions are met in the HMI.

The following alarms are supported.

- User alarms

Data Logging

You can log data to store the changes in the values of specified variables over time.

You can display the saved data with Trend Graph objects. You can also save this data to external files.

Recipes

A recipe is used to write data (numeric data or text strings) that was set in advance in the project to all of the specified variables as a group or to read all of the specified variables as a group.

You can manipulate the registered recipe data with Recipe Viewer objects.

Resources

You can manage resources, such as the text strings, movies, still images, and documents that are displayed for objects and alarms on pages.

1-2-9 Data That Retained When Power Is Turned OFF

The following data is retained when the power supply is turned OFF.

With No Battery or Low Battery Voltage

- Project data
- Log data that is not written to the SD Memory Card
- User alarm history
- Values of variables with Retain attribute
- Calibration information for touch panel

With Good Battery (in addition to the above)

- Clock information

1-3 Operating Procedure for HMIs

This section gives the operating procedure for an HMI and then describes it in more detail.

1-3-1 Overall Procedure

The overall procedure to use an HMI is given below.

STEP1 System Configuration and Project Design
Design the system configurations and project.

STEP 1-1 Designing the System Configurations
STEP 1-2 Designing the Project (Pages, Variables, Subroutines, etc.)



STEP2 Software Settings (Configurations and Setup) and Creating the HMI Application
Create the system configurations that you designed in step 1 on the Sysmac Studio. Also create the project (pages, variables, subroutines, etc.), build the project, and debug it with simulation and other functions.

Determining the Connected Device Variables and Mapping HMI Variables to Them (We recommend this as the basic procedure.)	Setting HMI Variables First and Then Mapping Them to Connected Device Variables
STEP 2-1 Starting the Sysmac Studio and Creating a Project	STEP 2-1 Starting the Sysmac Studio and Creating a Project
STEP 2-2 Software Settings (Configurations and Setup)	STEP 2-2 Creating the HMI Application
STEP 2-3 Creating the HMI Application	STEP 2-3 Software Settings (Configurations and Setup)
STEP 2-4 Building the HMI	STEP 2-4 Building the HMI
STEP 2-5 Offline Debugging	STEP 2-5 Offline Debugging



STEP3 Mounting and Wiring
Mount the HMI.
Connect the connected device and computer (Sysmac Studio) to the HMI.



STEP4 Confirming Operation and Starting Actual System Operation
Download the project from the Sysmac Studio.
Make the settings on the System Menu, check operation on the physical devices, and start operation.

1-3-2 Procedure Details

STEP1

System Configuration and Project Design

Step	Description	Reference
STEP 1-1 Designing the System Configurations	<ul style="list-style-type: none"> Connect an HMI to the external device. Connect an HMI to the Sysmac Studio. 	<i>Section 2 Configuration Units in NA Series Programmable Terminal Hardware User's Manual (V117)</i> <i>NA-series Programmable Terminal Device Connection User's Manual (V119)</i>
STEP 1-2 Designing the Project (Pages, Variables, Sub-routines, Etc.)	Design the project as given below.	<i>NA Series Programmable Terminal Software User's Manual (V118)</i>
1) Designing the Pages and Sub-routines	<ul style="list-style-type: none"> Design the contents to display on the pages (the pages and objects to use). Design the execution methods and contents of the subroutines. 	
2) Designing Items Shared by All Pages	<ul style="list-style-type: none"> Design the global events. Design the alarms, recipes, data logging, and other functions. 	
3) Variable Design	<ul style="list-style-type: none"> HMI external variable design: Design the mappings between the connected device variables and the HMI global variables. Design the HMI internal variables and subroutine variables. Define the attributes of the above variables, such as the Data Type, Name, and Retain attributes. 	



STEP2

Software Settings (Configurations and Setup) and Creating the HMI Application

Step	Description	Sysmac Studio operations	Reference
STEP 2-1 Starting the Sysmac Studio and Creating a Project	<ol style="list-style-type: none"> Start the Sysmac Studio and create a project. Insert the HMI. 	Press the New Project Button. Use HMI on the Insert Menu.	<i>Sysmac Studio Version 1 Operation Manual (W504)</i> <i>Section 2 Basic Sysmac Studio Operations</i>

● **Determining the Connected Device Variables and Mapping HMI Variables to Them**

We recommend this procedure as the basic procedure.

- Connecting to a Connected Device Registered in the Current Project

STEP 2-2 Software Settings (Configurations and Setup)	Make the initial software settings on the Sysmac Studio.	Use Configurations and Setup in the Multiview Explorer of the Sysmac Studio.	<i>Section 3 HMI Configuration and Setup</i>
• Mapping Variables	<ul style="list-style-type: none"> • Assign global variables to connected device variables (mapping variables). 	Map the variables under Configurations and Setup – Variable Mapping .	<i>3-3 Mapping Variables on page 3-7</i>
• HMI Settings	<ul style="list-style-type: none"> • Set the parameters related to the HMI. Startup Page, Brightness Settings, IP Address, FTP Settings, NTP Settings, FINS Settings, VNC Settings, etc. 	Make the settings under Configurations and Setup – HMI Settings .	<i>3-4 HMI Settings on page 3-10</i>
• Security Settings and Language Settings	<ul style="list-style-type: none"> • Set the operation rights to the HMI and the language to display on the HMI. 	Make the settings under Configurations and Setup – Security Settings and Configurations and Setup – Language Settings .	<i>3-5 Security Settings on page 3-17 3-6 Language Settings on page 3-18</i>

- Connecting to a Connected Device Not Registered in the Current Project

STEP 2-2 Software Settings (Configurations and Setup)	Make the initial software settings on the Sysmac Studio.	Use Configurations and Setup in the Multiview Explorer of the Sysmac Studio.	<i>Section 3 HMI Configuration and Setup</i>
• Device Settings	<ul style="list-style-type: none"> • Register the external connected devices. 	Add the connected device under Configurations and Setup – Device References .	<i>3-2 Device References on page 3-3</i>
	<ul style="list-style-type: none"> • You can do either of the following. <ul style="list-style-type: none"> a) Importing Variables from the Actual Connected Device: Place the Sysmac Studio online with the connected device and import the variables from the connected device. b) Importing Variables from Another Project: Copy the variable table in the other project and paste it in the variable table for the connected device to import the variables. 	<p>Set up communications and import the variables.</p> <p>Copy the variable table from another project using the clipboard.</p>	

• Mapping Variables	Assign global variables to connected device variables (mapping variables).	Map the variables under Configurations and Setup – Variable Mapping .	<i>Section 3 HMI Configuration and Setup and 3-3 Mapping Variables on page 3-7</i>
• HMI Settings	<ul style="list-style-type: none"> Set the parameters related to the HMI. Startup Page, Brightness Settings, IP Address, FTP Settings, NTP Settings, FINS Settings, VNC Settings, etc. 	Make the settings under Configurations and Setup – HMI Settings .	<i>3-4 HMI Settings on page 3-10</i>
• Security Settings and Language Settings	<ul style="list-style-type: none"> Set the operation rights to the HMI and the language to display on the HMI. 	Make the settings under Configurations and Setup – Security Settings and Configurations and Setup – Language Settings .	<i>3-5 Security Settings on page 3-17</i> <i>3-6 Language Settings on page 3-18</i>
STEP 2-3 Creating the HMI Application	Create the application (pages, variables, subroutines, etc.) with the Sysmac Studio.	Use HMI in the Multiview Explorer of the Sysmac Studio.	<i>Section 4 Creating the HMI Application</i>
1) Registering Variables	<ul style="list-style-type: none"> Register the variables in the HMI global variable table with the Sysmac Studio. <p>Note: Variables that were mapped in step 2-2 are automatically registered in the HMI global variables table.</p>	Use the editor for HMI – Data – Global Variables	<i>4-1 Registering Variables on page 4-2</i>
2) Creating Pages	<ul style="list-style-type: none"> Paste the objects on each page and set the object properties and other settings. 	Use the editor for HMI – Pages .	<i>4-2 Creating Pages on page 4-11</i>
3) Creating Subroutines	<ul style="list-style-type: none"> Create the subroutines. You can create the following. <ul style="list-style-type: none"> Global subroutines Page subroutines 	Subroutines shared by the entire project: Select HMI – Global Subroutine . Page subroutines: Use HMI – Pages Page Name and select View Code from the individual pages.	<i>4-4 Subroutines on page 4-27</i>
4) Settings Shared by All Pages	<ul style="list-style-type: none"> Make the settings that are shared by the project: alarms, recipes, data logging, global events, etc. 	Use HMI – User Alarms, HMI – Recipes , etc.	<i>4-3 Setting Common Object Functions on page 4-18</i>
STEP 2-4 Building the HMI	<ul style="list-style-type: none"> Convert the HMI project into a form that the HMI can execute. 	Use Build HMI on the Project Menu.	<i>4-6 Building on page 4-33</i>
STEP 2-5 Offline Debugging	<ul style="list-style-type: none"> Check the operation of the pages on the Simulator (a virtual HMI). 	Use Start NA Simulation or Run with Controller Simulator on the Simulation Menu.	<i>Section 7 Debugging</i>

● **Setting HMI Variables First and Then Mapping Them to Connected Device Variables**

STEP 2-2 Creating the HMI Application	Create the application (pages, variables, subroutines, etc.) with the Sysmac Studio.	Use HMI in the Multiview Explorer of the Sysmac Studio.	<i>Section 4 Creating the HMI Application</i>
1) Registering Variables	Register the variables in the HMI global variable table with the Sysmac Studio.	HMI – Data – Global Variables Table	<i>4-1 Registering Variables on page 4-2</i>
2) Creating Pages	Paste the objects on each page and set the object properties.	Use the editor for HMI – Pages .	<i>4-2 Creating Pages on page 4-11</i>
3) Creating Subroutines	Create the subroutines. You can create the following. <ul style="list-style-type: none"> • Global subroutines • Page subroutines 	Subroutines shared by the entire project: Select HMI – Add Global Subroutine . Page subroutines: Use HMI – Pages and select View Code from the individual pages.	<i>4-4 Subroutines on page 4-27</i>
4) Settings Shared by All Pages	Make the settings that are shared by the project: alarms, recipes, data logging, global events, etc.	Use HMI – User Alarms, HMI – Recipes , etc.	<i>4-3 Setting Common Object Functions on page 4-18</i>

• Connecting to a Connected Device Registered in the Current Project

STEP 2-3 Software Settings (Configurations and Setup)	Make the initial software settings on the Sysmac Studio.	Use Configurations and Setup in the Multiview Explorer of the Sysmac Studio.	<i>Section 3 HMI Configuration and Setup</i>
• Mapping Variables	<ul style="list-style-type: none"> • Assign global variables to connected device variables (mapping variables). 	Map the variables under Configurations and Setup – Variable Mapping .	<i>3-3 Mapping Variables on page 3-7</i>
• HMI Settings	<ul style="list-style-type: none"> • Set the parameters related to the HMI. Startup Page, Brightness Settings, IP Address, FTP Settings, NTP Settings, FINS Settings, VNC Settings, etc. 	Make the settings under Configurations and Setup – HMI Settings .	<i>3-4 HMI Settings on page 3-10</i>
• Security Settings and Language Settings	<ul style="list-style-type: none"> • Set the operation rights to the HMI and the language to display on the HMI. 	Make the settings under Configurations and Setup – Security Settings and Configurations and Setup – Language Settings .	<i>3-5 Security Settings on page 3-17</i> <i>3-6 Language Settings on page 3-18</i>

- Connecting to a Connected Device Not Registered in the Current Project

STEP2-3 Software Settings (Configurations and Setup)	Make the initial software settings on the Sysmac Studio.	Use Configurations and Setup in the Multiview Explorer of the Sysmac Studio.	<i>Section 3 HMI Configuration and Setup</i>
• Connected Device Settings	<ul style="list-style-type: none"> • Register the external connected devices. 	Add the connected device under Configurations and Setup – Device References .	<i>3-2 Device References on page 3-3</i>
	<ul style="list-style-type: none"> • You can do either of the following. <ul style="list-style-type: none"> a) Importing Variables from the Unit Connected Device: Place the Sysmac Studio online with the connected device and import the variables from the connected device. b) Importing Variables from Another Project: Copy the variable table in the other project and paste it in the device variable table. 	<p>Set up communications and import the variables.</p> <p>Copy the variable table from another project using the clipboard.</p>	<i>3-2-2 Connected Devices in the Current Project on page 3-3</i>
	<ul style="list-style-type: none"> • Assign global variables to connected device variables (mapping variables). 	Map the variables under Configurations and Setup – Variable Mapping .	<i>3-3 Mapping Variables on page 3-7</i>
• HMI Settings	<ul style="list-style-type: none"> • Set the parameters related to the HMI. Startup Page, Brightness Settings, IP Address, FTP Settings, NTP Settings, FINS Settings, VNC Settings, etc. 	Make the settings under Configurations and Setup – HMI Settings .	<i>3-4 HMI Settings on page 3-10</i>
• Security Settings and Language Settings	<ul style="list-style-type: none"> • Set the operation rights to the HMI and the language to display on the HMI. 	Make the settings under Configurations and Setup – Security Settings and Configurations and Setup – Language Settings .	<i>3-5 Security Settings on page 3-17</i> <i>3-6 Language Settings on page 3-18</i>
STEP 2-4 Building the HMI	<ul style="list-style-type: none"> • Convert the HMI project into a form that the HMI can execute. 	Use <i>Build HMI</i> on the Project Menu.	<i>4-6 Building on page 4-33</i>
STEP2-5 Offline Debugging	<ul style="list-style-type: none"> • Check the operation of the pages on the Simulator (a virtual HMI). 	Use <i>Start NA Simulation</i> or <i>Run with Controller Simulator</i> on the Simulation Menu.	<i>Section 7 Debugging</i>



STEP3 Mounting and Wiring

Step	Description	Reference
1) Mounting	<ul style="list-style-type: none"> Mount the HMI to the panel. Wire Power Supply. 	3-3 <i>Installing NA Units in NA Series Programmable Terminal Hardware User's Manual (V117)</i>
2) Wiring the Ethernet Cable to the Connected Device	<ul style="list-style-type: none"> Wire the Ethernet cables. 	3-4 <i>Wiring Method in NA Series Programmable Terminal Hardware User's Manual (V117)</i> <i>NA-series Programmable Terminal Device Connection User's Manual (V119)</i>
3) Connecting the Computer (Sysmac Studio)	<ul style="list-style-type: none"> Wire the USB cable. or Wire the Ethernet cable. 	2-4 <i>Support Software in NA Series Programmable Terminal Hardware User's Manual (V117)</i>



STEP4 Confirming Operation and Starting Actual System Operation

Step	Description	Sysmac Studio operations	Reference
1) Online Connection to Sysmac Studio and Project Download	<ul style="list-style-type: none"> Turn ON the power supply to the HMI and place the Sysmac Studio online. Then, download the project.*1 <p>*1. Use the Synchronize operation of the Sysmac Studio to download the project.</p>	Use Communications Setup on the HMI Menu. Use Synchronization on the HMI Menu.	Section 6 <i>Connecting to the HMI</i> and Section 8 <i>Synchronizing Projects</i>
2) Operation Check on NA Unit	<ul style="list-style-type: none"> Integrate the NA Unit into the actual system, manipulate the project that you created and confirm the following: that correct values are written to the connected device, that the pages change correctly, and that values set at the connected device are updated. 	---	Section 7 <i>Debugging</i>
3) Actual System Operation	<ul style="list-style-type: none"> Start actual operation. 	---	---

2

Basic Sysmac Studio Operations

This section describes basic operations on the Sysmac Studio.

2-1	Parts of the Sysmac Studio Window	2-2
2-1-1	Application Window	2-2
2-2	Menu Command Structure	2-6
2-3	Basic Editing Operations	2-8
2-4	Sysmac Studio Settings and Operations	2-10
2-4-1	Setting Parameters	2-10
2-4-2	Programming	2-10
2-4-3	Library Functions	2-11
2-4-4	Operations for Debugging	2-11
2-4-5	Communications	2-11
2-4-6	Security Measures	2-11
2-4-7	Online Help	2-12
2-5	Basic Operations for HMI Projects	2-13
2-5-1	Creating a Project File from the Project Window	2-13
2-5-2	Adding an HMI to an Existing Project	2-14
2-5-3	Changing Devices	2-15

2-1 Parts of the Sysmac Studio Window

This section gives the names and functions of the parts of the Sysmac Studio Window.

This manual describes only functions that apply when an HMI is selected for the device. For information on Sysmac Studio functions not described in this manual, refer to the *Sysmac Studio Version 1 Operation Manual* (Cat. No. W504).



Precautions for Correct Use

When you use the Sysmac Studio, use the standard Windows desktop theme. If you do not use the standard Windows desktop theme, part of the display may not be correct.

2-1-1 Application Window

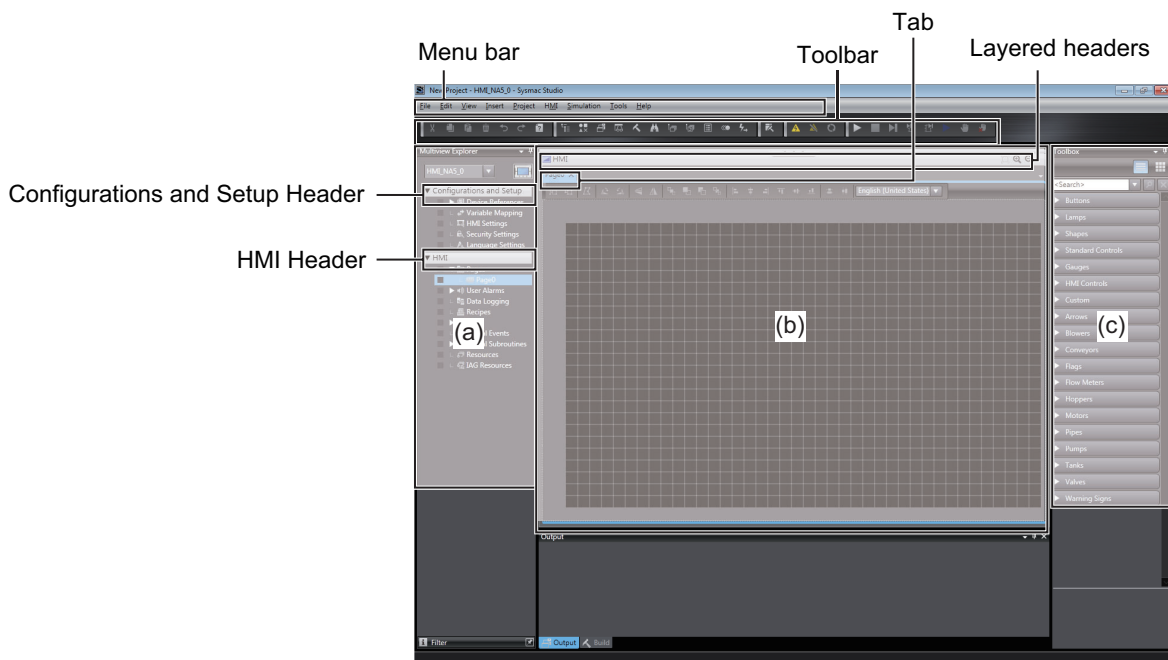

Number	Name
(a)	Multiview Explorer
(b)	Edit Pane
(c)	Toolbox

The functions of these parts are described starting on the next page.

Multiview Explorer (a)

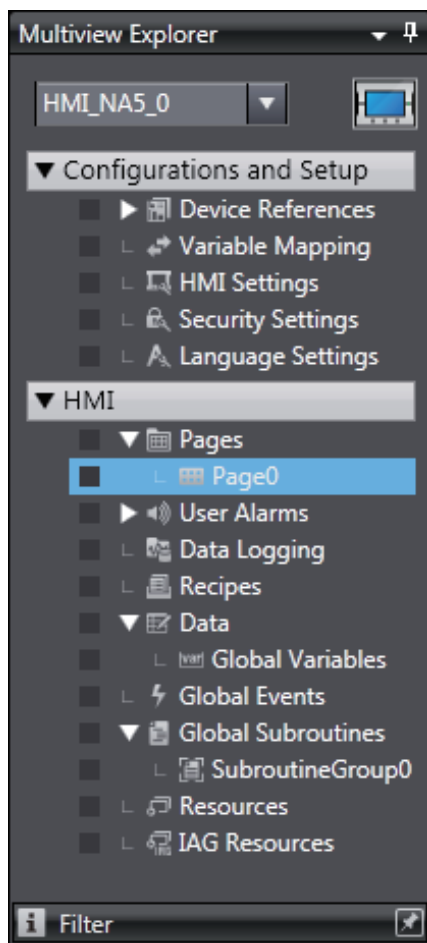

- This pane is your access point for all Sysmac Studio data. When an HMI is selected, it is divided into a Configurations and Setup Layer and an HMI Layer.
- You can also display the Page Explorer to display lists of objects on pages or the Code Explorer to display lists of subroutines.

● **Layers and Items in the Multiview Explorer**

Configurations and Setup
Device References
Variable Mapping
HMI Settings
Security Settings
Language Settings

HMI
Page
Pages
User Alarms
Groups
Data Logging
DataSet
Recipes
Data
Global Variables
Global Events
Global Subroutines
Subroutine Groups
Resources
IAG Resources



Precautions for Correct Use

You cannot download the data to the HMI if an error icon is displayed.

● **Page Explorer**

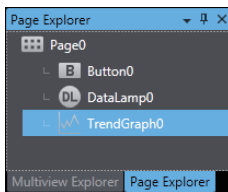

The Page Explorer displays a list of objects on a page. If you click an object in the Page Explorer, the object will be selected on the Edit Pane.

To change the attributes for grouped objects or for individual objects in IAGs, select the individual objects on the Page Explorer.

● **Code Explorer**

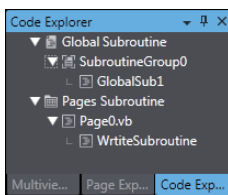

The Code Explorer displays the subroutines in the project. You can double-click a subroutine to edit it.

Edit Pane (b)

The basic Sysmac Studio operations on the Edit Pane generally apply to HMIs. If an HMI is selected, you can edit pages and set up the HMI.

Toolbox (c)

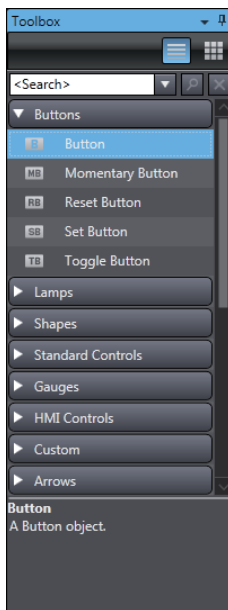

- The Toolbox shows the objects that you can use to edit the page that is displayed in the Edit Pane.

You can also display the Properties Window, Animations Window, and Events and Actions Window to make the settings of the objects.

2-2 Menu Command Structure

The menu commands that are displayed when an HMI is selected as the device are listed below.

Menu	Submenu/command		
File	Close		
	Save		
	Save As		
	Save As New Number	—	
	Import		
	Export		
	Exit		
Edit	Undo		
	Redo		
	Cut		
	Copy	—	
	Paste		
	Delete		
	Select All		
	Search and Replace		
View	Multiview Explorer		
	Toolbox		
	Output Tab Page		
	Watch Tab Page		
	Build Tab Page		
	Search and Replace Results Tab Page	—	
	Page Explorer		
	Code Explorer		
	Properties		
	Animations		
	Events and Actions		
	Zoom	Zoom In	
		Zoom Out	
Zoom to Fit			
Zoom Reset			
Reset Window Layout	—		
Insert	Controller	NJ301	
		NJ501	
	HMI	NA5	
	Measurement Sensor	ZW	
	Vision Sensor	FQ-M	
		FH	
	External Device		
	Page		
	Page Group		
	User Alarm Group	—	
	Data Set		
Recipe			
Global Subroutine Group			
Project	Build HMI		
	Abort Build	—	
	IAG Collections Manager		

Menu	Submenu/command	
HMI	Communications Setup	
	Change Device	
	Online	
	Offline	
	Synchronization	—
	Transfer to Media Device	
	HMI Clock	
	Update HMI Name	
	Security	HMI Write Protection
	Clear All Memory	—
	Reset HMI Device	
	Simulation	Start NA Simulation
Stop NA Simulation		
Step Execution		
Step In		
Step Out		—
Continue		
Set/Clear Breakpoint		
Clear All Breakpoints		
Run with Controller Simulator		
Tools		Option
Help	Help Contents	
	Keyboard Mapping Reference	—
	Online Registration	
	About Sysmac Studio	

2-3 Basic Editing Operations

This section describes differences in basic Sysmac Studio operation when an HMI is selected as the device.

Entry Assistance

There are some differences in the standard operation of the Sysmac Studio when an HMI is selected as the device. This section describes those differences.

● Entering Variable Names and Data Types

- Entering variable names, e.g., when setting properties
- Entering data types in variable tables

Example: When you enter a variable name as a property, the variable names that you can enter are displayed in a list.

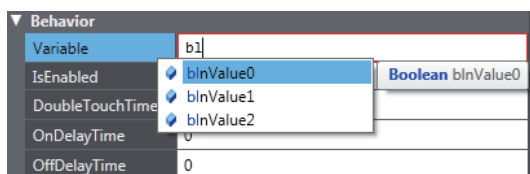

● Entering Text in the Code Editor

- When you enter text in the Code Editor, the cursor moves to the first item in the list that starts with the character that you entered.

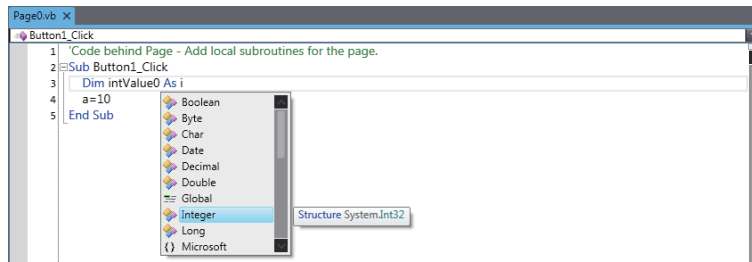

- When you press the **Tab** Key after entering the first part of the keyword ("in" in this example), the rest of the keyword is automatically entered.

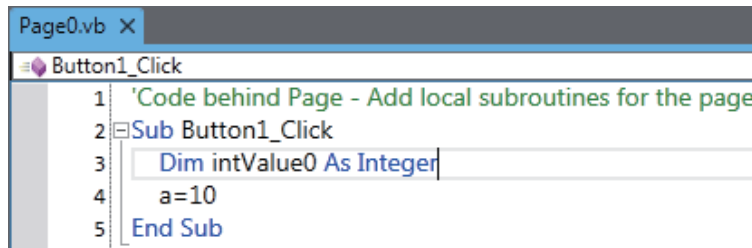

2-4 Sysmac Studio Settings and Operations

This section lists the operations of the Sysmac Studio that can be used only when an HMI is selected.

2-4-1 Setting Parameters

Item	Description	Reference
HMI Settings	You can make settings for an HMI.	<i>Section 3 HMI Configuration and Setup</i>
Device References	If you connect an HMI to a device (e.g., Controller or PLC) that is not registered in the current HMI project, the connected external device will be added.	3-2 Device References on page 3-3
Internal Projects	Controllers registered in the project are displayed.	
External Device	You can set up communications and import variables for connected devices that have been added.	
Variable Mapping	You can associate variables in the connected devices with variables in the HMI.	3-3 Mapping Variables on page 3-7

2-4-2 Programming

Item	Description	Reference
Toolbox	The Toolbox displays a list of the objects that you can use. You can search for the required objects and drag them to the Page Editor to position the objects.	<i>Section 5 Objects</i>
Properties	You can set the static attributes of the pages and objects.	
Animations	You can set the operations for object condition expressions.	
Events and Actions	You can set the actions to perform when events occur.	
Page Explorer	The Page Explorer displays a list of objects on a page. You can select objects or change the order of the display.	
Code Explorer	The Code Explorer displays lists of subroutines in the project. You can double-click a subroutine to edit it.	
Page Editor	You can position objects and create pages. You can also use the Page Editor to make settings for objects.	
Code Editor	You can use Visual Basic to create subroutines.	4-4 Subroutines on page 4-27

Item		Description	Reference
Search and Replace		You can search and replace strings in subrou-tine data.	4-5 <i>Search and Replace</i> on page 4-32
Build	Build HMI	Convert the project into a form that the HMI can execute.	4-6 <i>Building</i> on page 4-33
	Abort Build	You can abort a build operation.	

2-4-3 Library Functions

Item		Description	Reference
Toolbox		You can register objects that you have created and then reuse them.	<i>Section 9 Reusing Objects</i>
IAG		You can output an IAG that you created in an IAG project as an IAG collection, to use it in another project.	

2-4-4 Operations for Debugging

Item		Description	Reference
Monitoring		You can monitor variables during project execu-tion. You can monitor the present values of HMI global variables. You use the Watch Tab Page for monitoring.	<i>Section 7 Debugging</i>
Changing the Present Values of Variables		You can change the present values of global variables and system-defined variables. You can do this on a Watch Tab Page.	
Controlling Execution with Breakpoints and Step Execu-tion		You can control simulation execution to monitor the program or to check operation. Step execution and pausing are also possible.	<i>Section 7 Debugging</i>

2-4-5 Communications

Item		Description	Reference
Going Online with an HMI		You can place the computer online with an HMI to synchronize the project.	<i>Section 6 Connecting to the HMI</i>

2-4-6 Security Measures

Item		Description	Reference
Prevention of Incorrect Con-nections	Confirming HMI device Names and Serial IDs	If the device name or the serial ID is different between the project and the HMI when an online connection is established, a confirmation dialog box is displayed.	3-5 <i>Security Settings</i> on page 3-17
Preventing Incor-rect Operation	Operation Author-ity Verification	You can use operation authorities to restrict the ability to perform operations or display data.	
Prevention of the Theft of Assets	Password Protec-tion for Project Files	You can set password protection for project files to protect your assets.	

2-4-7 Online Help

Item	Description	Reference
Sysmac Studio Help System	You can access Sysmac Studio operating procedures.	
Keyboard Mapping Reference	You can display a list of convenient shortcut keys that you can use on the Sysmac Studio.	

2-5 Basic Operations for HMI Projects

This section describes how to create and save projects and perform other basic operations to use HMIs.

2-5-1 Creating a Project File from the Project Window

Use the following procedure to create a project file from the Project Window.

- 1 Click the **New Project** Button in the Project Window.

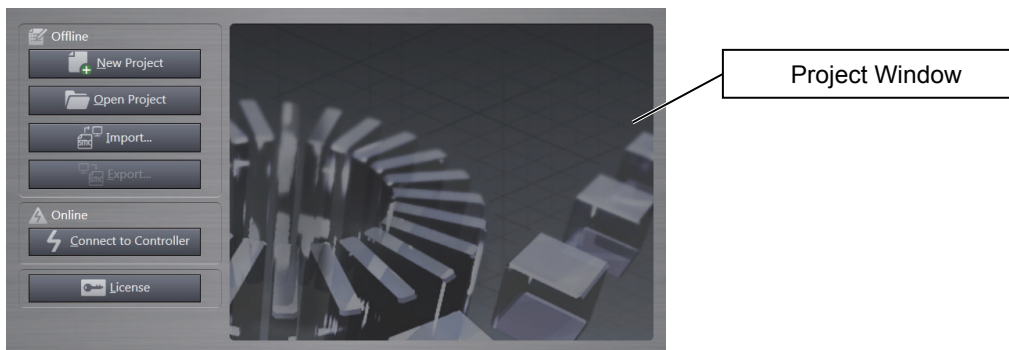

The Project Properties Dialog Box is displayed. The following table gives the functions of the buttons.

Menu command	Description
New Project Button	Creates a project file.
Open Project Button	Opens an existing project file.

- 2 Enter the project name, author, and comment in the Project Properties Dialog Box, select *HMI* from the device category, and then click the **Create** Button. (Only the project name is required.)

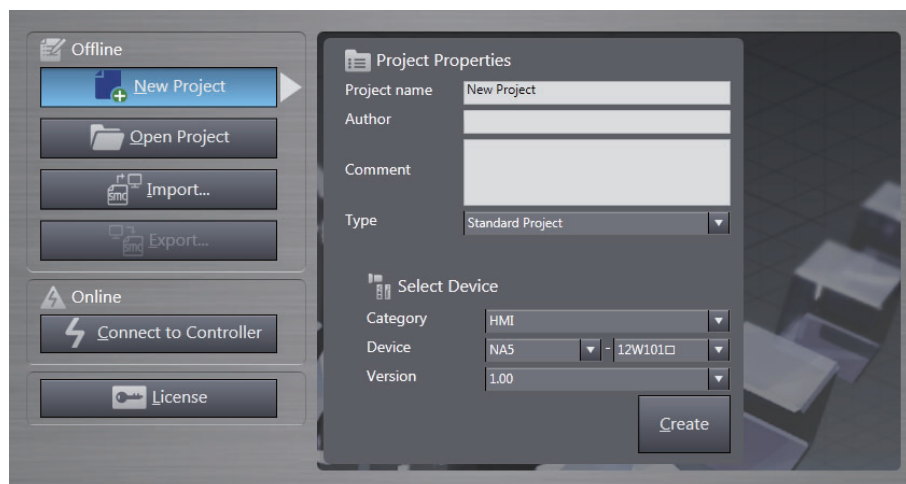

You can change the properties later. Refer to the *Sysmac Studio Version 1 Operation Manual* (Cat. No. W504).

A project file is created and the following window is displayed.

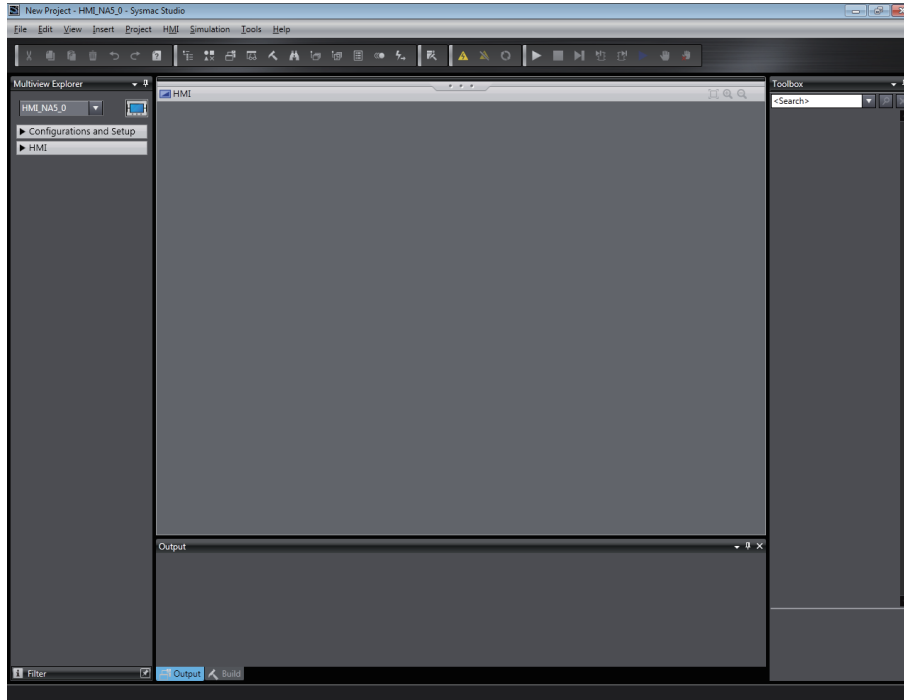

A project file is created with the specified device already inserted.

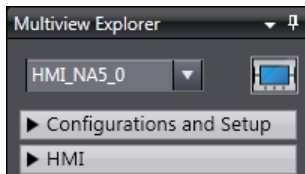

2-5-2 Adding an HMI to an Existing Project

Right-click the Controller Icon and select **Add Device** from the menu.

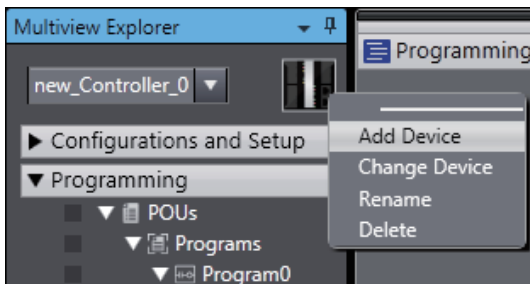

Or, select the device directly from the Insert Menu.

Example: **HMI - NA5**: The Add Device Dialog Box is displayed.

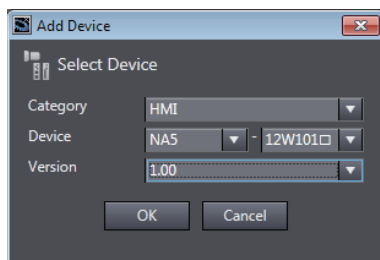

Select the device and then click the **OK** Button. The device is added to the project.

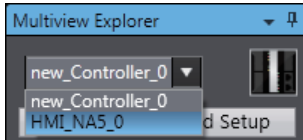

To change the target device, select a device from the list.

2-5-3 Changing Devices

Right-click the HMI Icon and select **Change Device** from the menu. Or, select **Change Device** from the HMI Menu.

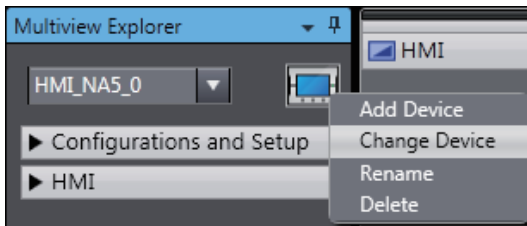

The Change Device Dialog Box is displayed.

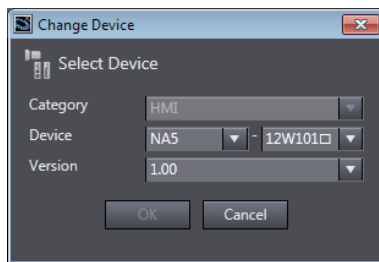

Select the device and then click the **OK** Button. The device is changed.



Precautions for Correct Use

- If you change the device, the settings for functions that are not supported by the new model will be lost.
- If you change to a model that has a different display size, the objects will be enlarged or reduced according to the new display size. However, elements other than objects, such as font sizes, will not change.

HMI Versions

Set the version when you create a new HMI project or when you add an HMI to an existing project.

You can set the version to the runtime version of the HMI that you are using or to any earlier runtime version. You can program and make settings within the ranges that are supported for the runtime version that you set for the HMI. If you attempt to use functions that are not supported by the runtime version that you set, you will not be able to use them or errors will occur.

3

HMI Configuration and Setup

This section describes how to configure and set up HMIs on the Sysmac Studio, including mapping variables with connected devices and HMI settings.

3-1	Outline of Configurations and Setup	3-2
3-1-1	Connected Device Registration and Variable Mapping	3-2
3-2	Device References	3-3
3-2-1	Types of Connected Devices	3-3
3-2-2	Connected Devices in the Current Project	3-3
3-2-3	Registering External Connected Devices	3-4
3-3	Mapping Variables	3-7
3-3-1	Mapping Variables	3-7
3-3-2	Opening the Variable Mapping Tab Page and Tab Page Parts	3-7
3-3-3	Variable Mapping Methods	3-8
3-4	HMI Settings	3-10
3-4-1	HMI Settings	3-10
3-4-2	Device Settings	3-11
3-4-3	TCP/IP Settings	3-12
3-4-4	FTP Settings	3-13
3-4-5	NTP Settings	3-14
3-4-6	FINS Settings	3-15
3-4-7	VNC Settings	3-16
3-5	Security Settings	3-17
3-6	Language Settings	3-18
3-7	HMI Clock	3-19
3-8	Updating the HMI Name	3-20
3-9	Write Protecting the HMI	3-21
3-10	Clear All Memory	3-22
3-11	Resetting the HMI	3-23

3-1 Outline of Configurations and Setup

This section describes how to set up HMIs and connected devices, such as Controllers and PLCs. The following items are provided in the HMI Configurations and Setup.

Item	Description
Device References	You can set up connected devices and import variables.
Variable Mapping	You can assign HMI variables to the variables in the connected devices.
HMI Settings	These are the parameters related to the HMI.
Security Settings	You can set up restrictions to operations on HMIs.
Language Settings	You can make settings for multi-language projects.

3-1-1 Connected Device Registration and Variable Mapping

Device references must be set only to connect to external devices that are not registered in the current project. They are not necessary to connect to a Controller that is registered in the current project.

The following figure shows the relationship between connected device references and variable mapping.

The HMI global variables are mapped to the connected device variables.

To access variables in the connected devices from an HMI, you must map the variables.

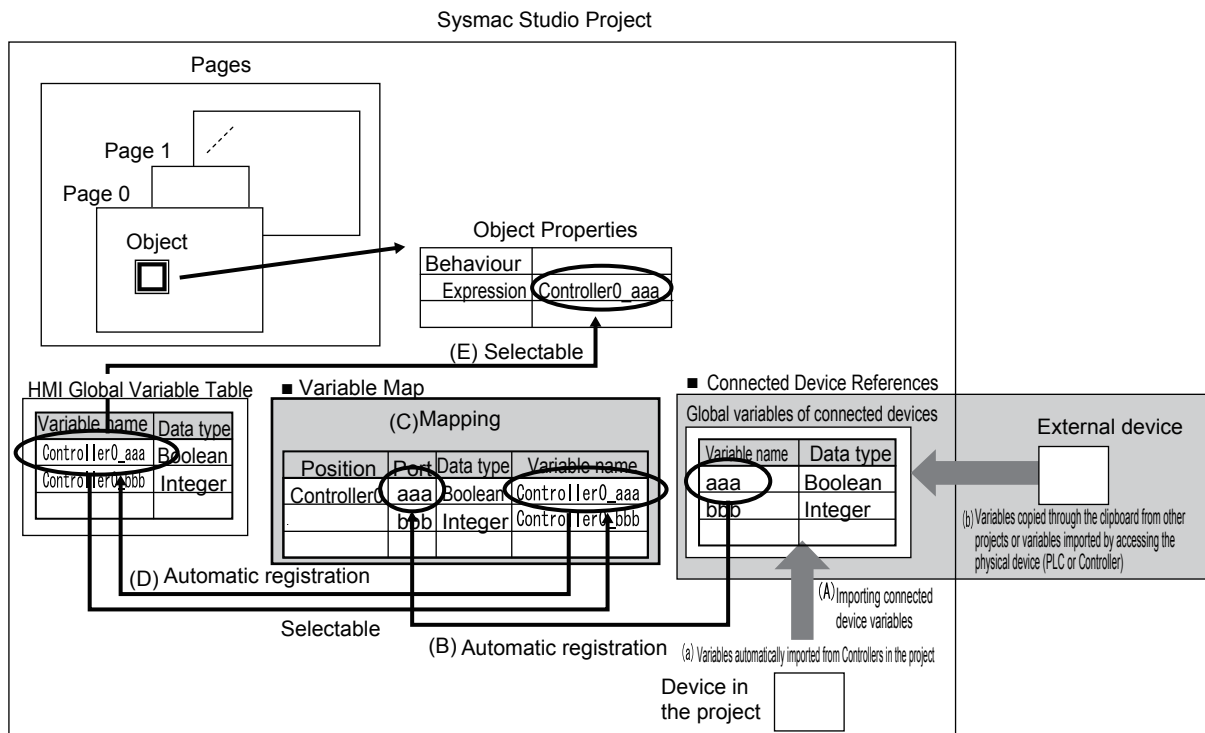

- Connected device variables are a) automatically imported from the same project or b) copied from another project or manually imported from an external device.
- The connected device variables are automatically registered in the variable mappings.
- The HMI global variables are mapped to the connected device variables.
- The mapped HMI global variables are automatically registered in the global variable table of the HMI.
- You specify HMI global variables in the object properties.

3-2 Device References

This section describes how to set up HMIs and connected devices, such as Controllers and PLCs.

3-2-1 Types of Connected Devices

Different operations are used to connect to Controllers that are registered and Controllers that are not registered in the current project.

- Controllers that are already registered in the current project are automatically registered in the HMI project as internal connected devices.
- To connect to a device that is not registered in the current HMI project, you must register the device as an external connected device.

3-2-2 Connected Devices in the Current Project

Controllers that are registered in the current project are displayed as connected devices. Use the following procedure to display the device settings if you need to check them.

- 1 Click **Device References** under **Configurations and Setup** in the Multiview Explorer.
- 2 The Controllers that are registered in the current project are displayed under **Internal Projects**.
- 3 Double-click the project to display the following Device Configuration Tab Page.

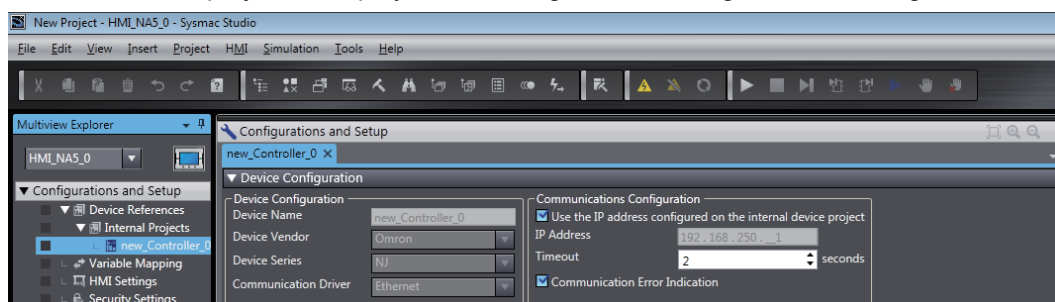

3-2-3 Registering External Connected Devices

To connect the HMI to a device that is not registered in the current HMI project, you must register the device as an external connected device. The procedures to register and set up external connected devices are given below.

Registering and Setting Up External Connected Devices

This section describes how to register and set up external connected devices.

- 1 Right-click **Device References** under **Configurations and Setup** in the Multiview Explorer.

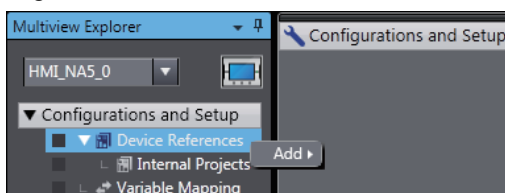

- 2 Select **Add - ExternalDevice**. The device is added as ExternalDevice□, where □ is a serial number starting from 0.

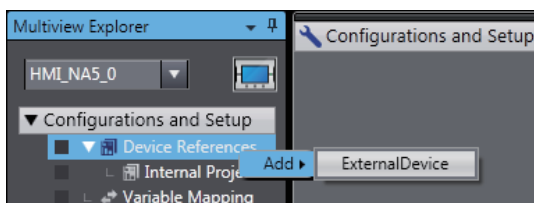

- 3 Double-click the new ExternalDevice□.

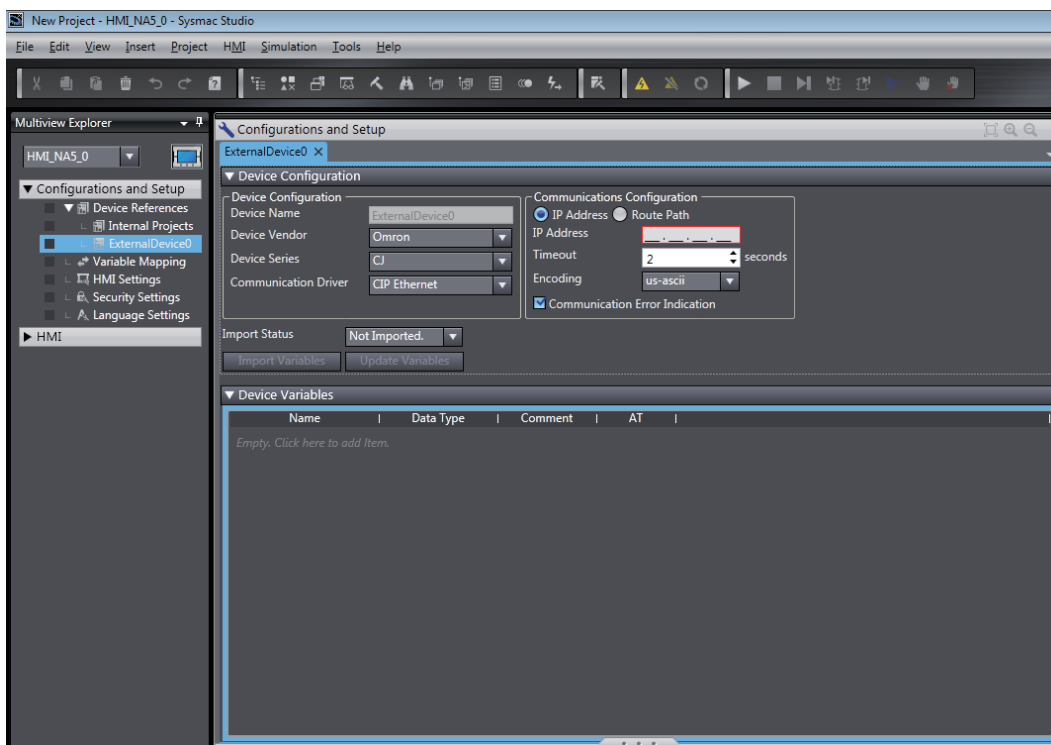

- 4 Select the vendor of the required device in the *Device Vendor* Box under **Device Configuration**. The device series of the selected vendor is displayed. Make the selections for the required device. The device communications drivers of the vendor selected for the device series are displayed. Select the communications driver for the required device.

The screenshot shows the configuration window for 'ExternalDevice0'. It is divided into two main sections: 'Device Configuration' and 'Communications Configuration'. In the 'Device Configuration' section, the 'Device Vendor' is set to 'Omron', 'Device Series' is 'NJ', and 'Communication Driver' is 'Ethernet'. The 'Communications Configuration' section shows the 'IP Address' field with a red box around it, 'Timeout' set to '2' seconds, and the 'Communication Error Indication' checkbox checked. Below these sections are 'Import Status' (set to 'Not Imported'), 'Import Variables', and 'Update Variables' buttons. At the bottom, there is a 'Device Variables' table with columns for Name, Data Type, Comment, and AT, and a note that says 'Empty. Click here to add Item.'

- 5 Make the required settings in the *Communications Configuration* Area. Refer to the *NA-series Programmable Terminal Device Connection User's Manual* (Cat. No. V119) for details.

This screenshot is identical to the previous one, but the 'IP Address' field in the 'Communications Configuration' section is now filled with the value '192.168.250.1'. The other settings remain the same.

Importing External Connected Device Variables

To connect the HMI to a device that is not registered in the current HMI project, you must import the variables from the external connected device.

There are two ways to import external connected device variables.

- Importing device variables online from the actual external connected device
- Copying variables from the variable table in another project

● Importing Device Variables Online from the Actual External Connected Device

Click the **Import Variables** Button. The variables are imported from the external connected device.

Refer to the *NA-series Programmable Terminal Device Connection User's Manual* (Cat. No. V119) for details.

● Copying Variables from the Variable Table in Another Project

You can use the clipboard to copy the required variables from the Support Software for the connected device and paste them in the device variables table for the external connected device. However, you cannot copy connected device variables if they are structure variables.

Refer to the *NA-series Programmable Terminal Device Connection User's Manual* (Cat. No. V119) for details.

Updating Device Variables

If you change the variables on a device, update the device variables in the HMI project as required.

There are two ways to update device variables.

- Updating device variables online from the actual external connected device
- Copying variables from the variable table in another project

● Updating Device Variables Online from the Actual External Connected Device

Click the **Update Variables** Button. The differences between the variables on the external connected device and the device variables in the HMI project are displayed. Select the variables to update.

● Copying Variables from the Variable Table in Another Project

You can use the clipboard to copy the required variables from the Support Software for the connected device and paste them in the device variables table for the external connected device.

3-3 Mapping Variables

This section describes the settings required to access variables in connected devices through HMI global variables.

3-3-1 Mapping Variables

Mapping variables refers to assigning variables in devices connected to the HMI (called device variables) to global variables in the HMI. Device variables are used on the HMI by assigning them to HMI global variables.

Therefore, mapping variables is required. Not accessing device variables directly allows you to reuse projects simply by changing the variable mappings.

Global variables that are assigned to device variables are called external variables.

3-3-2 Opening the Variable Mapping Tab Page and Tab Page Parts

- 1 Double-click **Variable Mapping** under **Configurations and Setup**.

The Variable Mapping Tab Page is displayed.

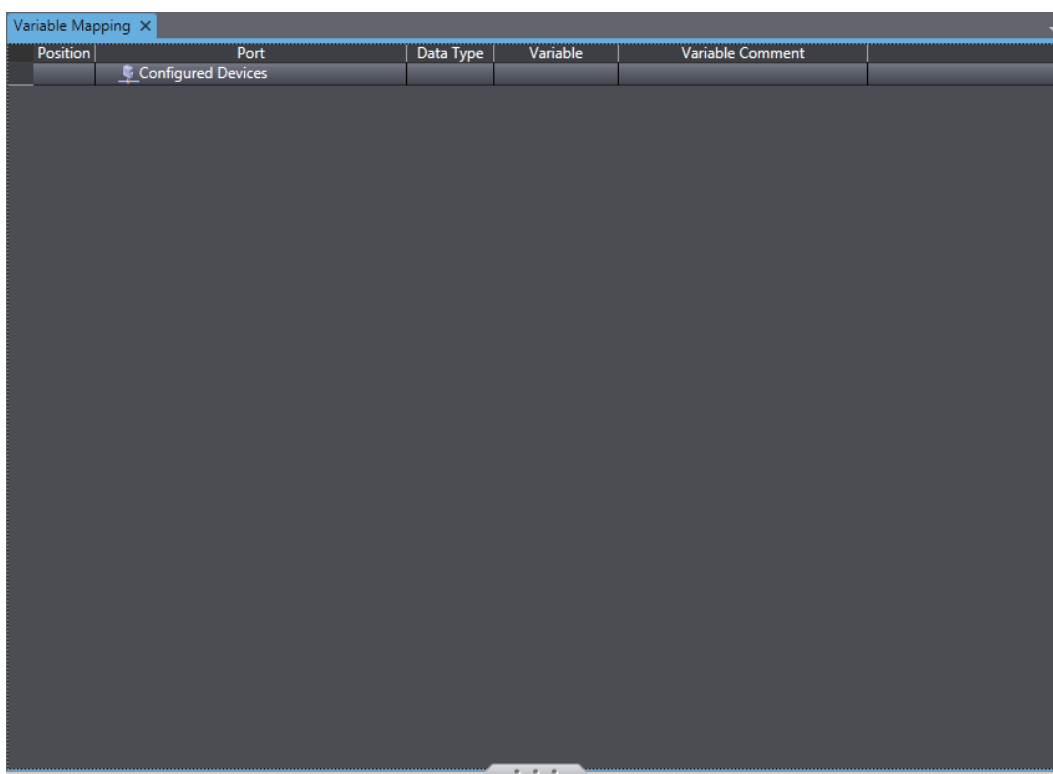

Parts of the Window

No	Item	Description
1	Position	Displays the IP addresses of the connected devices.
2	Port	Displays the connected devices and device variables in a tree structure.
3	Data Type	The data types of the device variables are displayed.

No	Item	Description
4	Variable	You can set the name of a HMI global variable. You can use entry assistance to select from a list of previously registered HMI global variables.
5	Variable Comment	You can set comments for the HMI global variables. These comments are also applied to the global variable table.

3-3-3 Variable Mapping Methods

To map variables, you can either create new global variables and assign them or you can assign previously created global variables.

To increase the reusability of the project, create the global variables first and then assign them.

However, if a device variable is a structure, you must create a new external variable during variable mapping.

Creating New External Variables

You can create a new global variable and assign it to a device variable.

When you create an external variable, you can either have the name generated automatically or you can create it manually.

● Automatically Creating New Variable Names

Use the following procedure.

- 1 Select one or more device variables in the variable mappings, right-click, and select **Create Device Variable** from the popup menu.

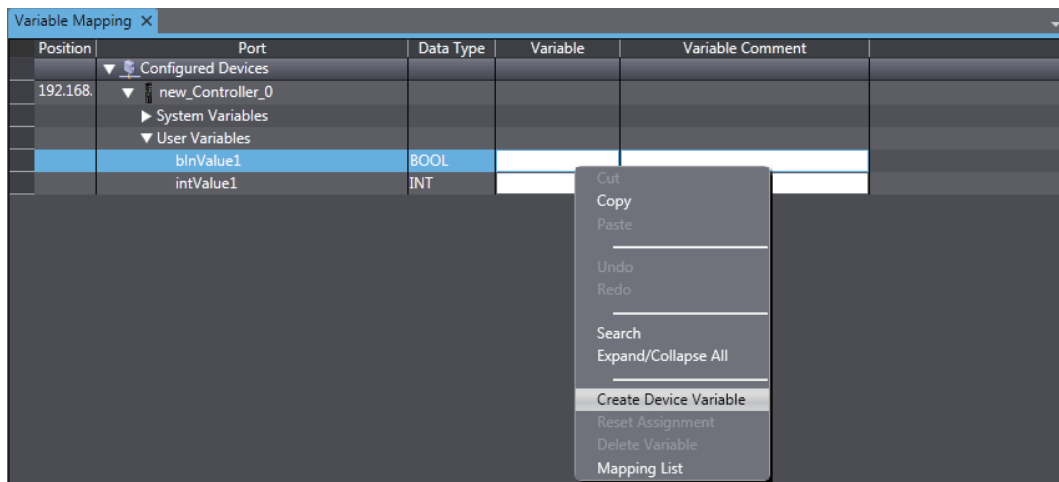

Automatically generated variable names are registered in the global variable table according to the following rule.

Automatic generation rule: The device variable name is added after the controller name and separated with an underline.

● Manually Entering New Variable Names

Select the device variable and directly enter the variable name in the *Variable* column.

Selecting Previously Registered Global Variables and Mapping Them

You can select global variables that are already registered in the global variable table and assign them to device variables.

For example, this method can be used to map external variables in the following cases.

- Setting an HMI global variable first and then assigning it to a device variable
- Creating a common project first and specifying connected devices later

Use the following procedure.

- 1 Register the global variables in the global variable table in advance.
- 2 When you map variables, you can select global variables from lists of variables that are already registered in the global variable table and assign them to device variables.

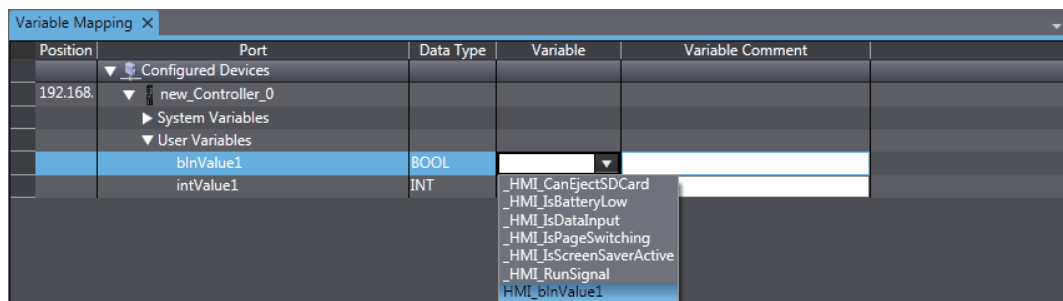







3-4 HMI Settings

This section describes the HMI settings.

3-4-1 HMI Settings

You can make settings for an HMI.

The following table lists the setting items.

Item	Icon	Description	When setting is required
Device Settings		There are page, screen saver, brightness settings, and other settings.	These settings are always required.
TCP/IP Settings		These are the Ethernet settings for Ethernet ports 1 and 2.	These settings are always required.
FTP Settings		These are the FTP server settings.	These settings are required to use the FTP server.
NTP Settings		These are the NTP client settings.	These settings are required when you use an NTP client.
FINS Settings		These are the settings for FINS communications.	These settings are required when using FINS communications with a CJ-series PLC.
VNC Settings		These are the VNC settings.	These settings are required to use VNC.

Setting Procedure for HMI Settings

- 1** Double-click **HMI Settings** under **Configurations and Setup** in the Multiview Explorer. The HMI Settings Tab Page is displayed in the Configurations and Setup Layer.
- 2** Click the icons on the left to display the corresponding dialog boxes.

3-4-2 Device Settings

These are the device settings.

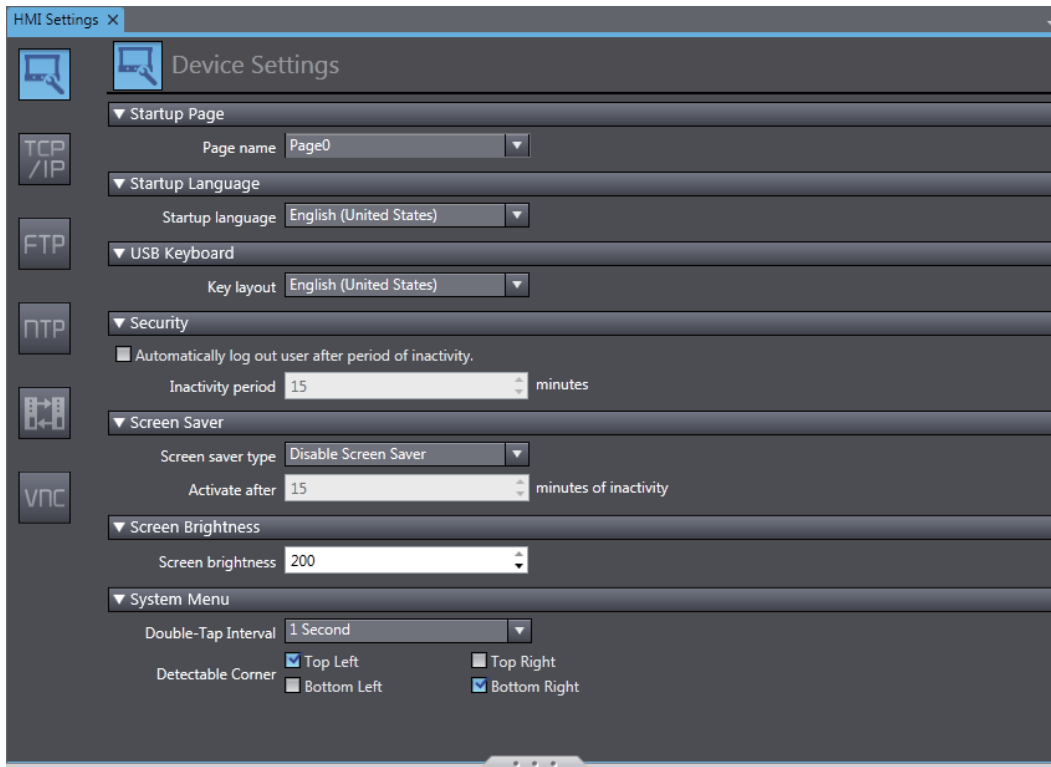

Item	Description
Startup Page	
Page name	Sets the page to display first when the HMI is started.
Startup Language	
Startup language	Sets the project language to use when the HMI is started.
USB Keyboard	
Key layout	Sets the layout of a USB keyboard.
Security	
Automatically log out user after period of inactivity.	Select this check box to automatically log out the user after a specified period of inactivity.
Inactivity period	Specify the time of inactivity before the user is logged out automatically.
Screen Saver	
Screen saver type	Sets the type of screen saver.
Active after	Sets the time after the screen is touched before the screen saver is started.
Screen Brightness	
Screen brightness	Sets the brightness of the screen.
System Menu	
Double-tap Interval	Sets the interval to use to detect double taps.
Detectable corner	Select the corners in which to detect the operation to display the System Menu.

3-4-3 TCP/IP Settings

These are the settings for TCP/IP.

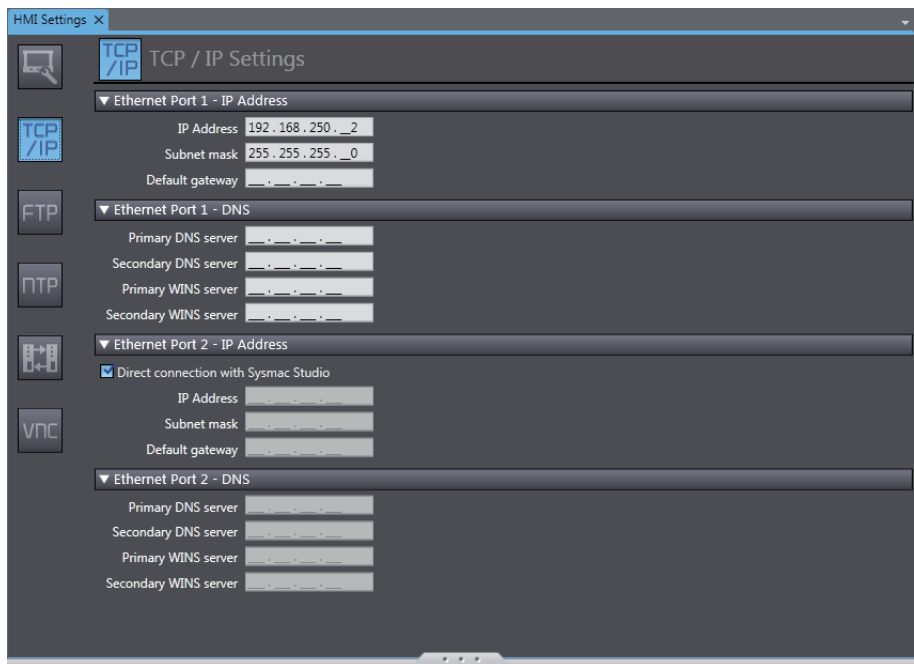

The following settings are provided for Ethernet port 1 and Ethernet port 2.

Item	Description
Ethernet Port 1 - Settings	
IP Address	Sets the local IP address.
Subnet mask	Sets the subnet mask.
Default gateway	Sets the IP address of the default gateway. This setting is not required when a default gateway is not used.
Primary DNS server	Sets the IP address of the primary DNS server.
Secondary DNS server	Sets the IP address of the secondary DNS server.
Primary WINS server	Sets the IP address of the primary WINS server.
Secondary WINS server	Sets the IP address of the secondary WINS server.
Ethernet Port 2 - Settings	
Direct connection with Sysmac Studio	Select this check box to connect Ethernet port 2 directly to the Sysmac Studio without going through an Ethernet switch. If you select this check box, the IP addresses and other settings for Ethernet port 2 are ignored.
IP Address	Sets the local IP address.
Subnet mask	Sets the subnet mask.
Default gateway	Sets the IP address of the default gateway. This setting is not required when a default gateway is not used.
Primary DNS server	Sets the IP address of the primary DNS server.
Secondary DNS server	Sets the IP address of the secondary DNS server.
Primary WINS server	Sets the IP address of the primary WINS server.
Secondary WINS server	Sets the IP address of the secondary WINS server.

3-4-4 FTP Settings

These are the FTP server settings.

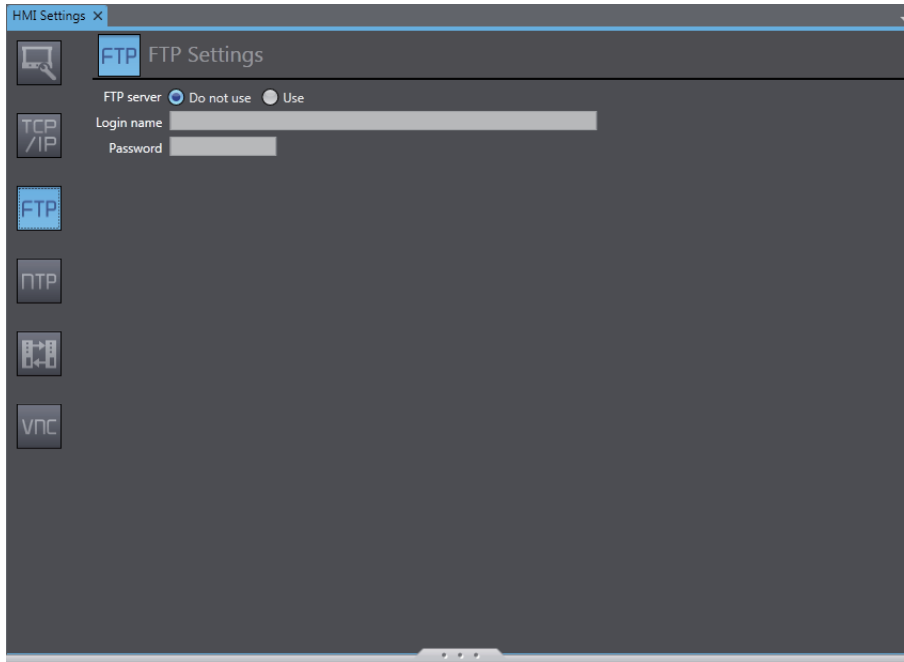

Item	Description
FTP Settings	
FTP server	Specifies whether to use the FTP server of the HMI.
Login name	Sets the login name to externally connect to Ethernet port 1 or 2 on the HMI via FTP. You can use up to 12 alphanumeric characters.
Password	Sets the password to use to externally connect to Ethernet port 1 or 2 via FTP. You can use 8 to 32 alphanumeric characters.

3-4-5 NTP Settings

These are the settings for an NTP (Network Time Protocol) client.

The HMI gets the clock information from the specified NTP server at the specified interval and updates the built-in clock information.

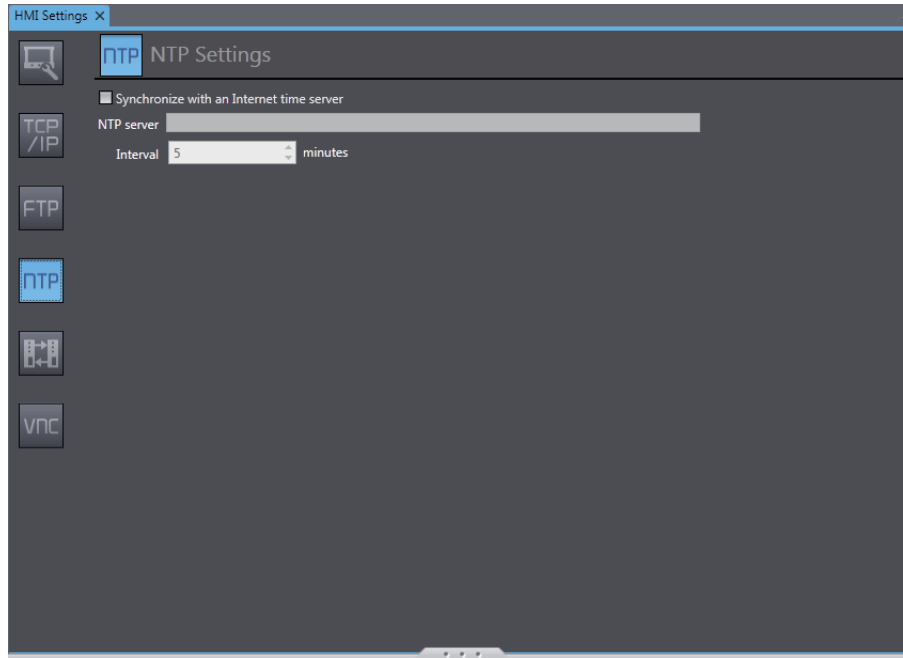

Item	Description
NTP Settings	
Synchronize with an Internet time server	Select this check box to synchronize the built-in clock in the HMI with the clock information from the NTP server.
NTP server	Sets the IP address of the NTP server.
Interval	Sets the interval at which to get the clock information from the NTP server.

3-4-6 FINS Settings

These are the settings for FINS communications.

These settings are required when FINS communications are used between the HMI and a CJ-series PLC.

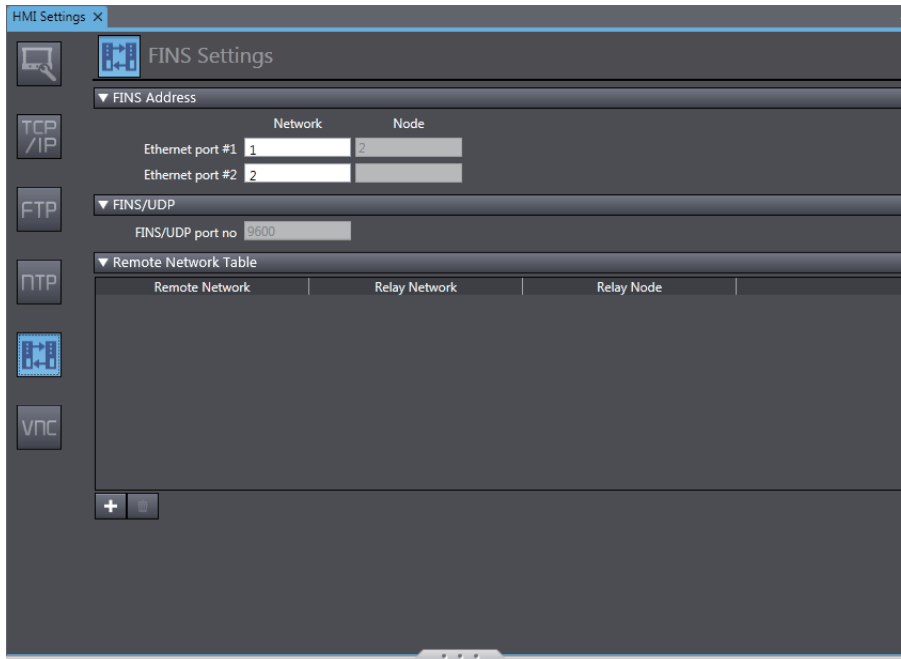

Item	Description
FINS Address	
Ethernet port #1	Sets the FINS network address of Ethernet port 1. The FINS node address is automatically created from the IP address.
Ethernet port #2	Sets the FINS network address of Ethernet port 2. The FINS node address is automatically created from the IP address.
FINS/UDP	
FINS/UDP port no	Displays the port number used for FINS/UDP.
Remote Network Table	Sets the routing table.

3-4-7 VNC Settings

These are the settings for VNC (Virtual Network Computing).

VNC implements a remote desktop to allow remote control of a computer located on a network.

You must enable the server functionality on the HMI to control. You can start the client software on the computer from which to perform remote control, connect to the HMI, and then control it remotely.

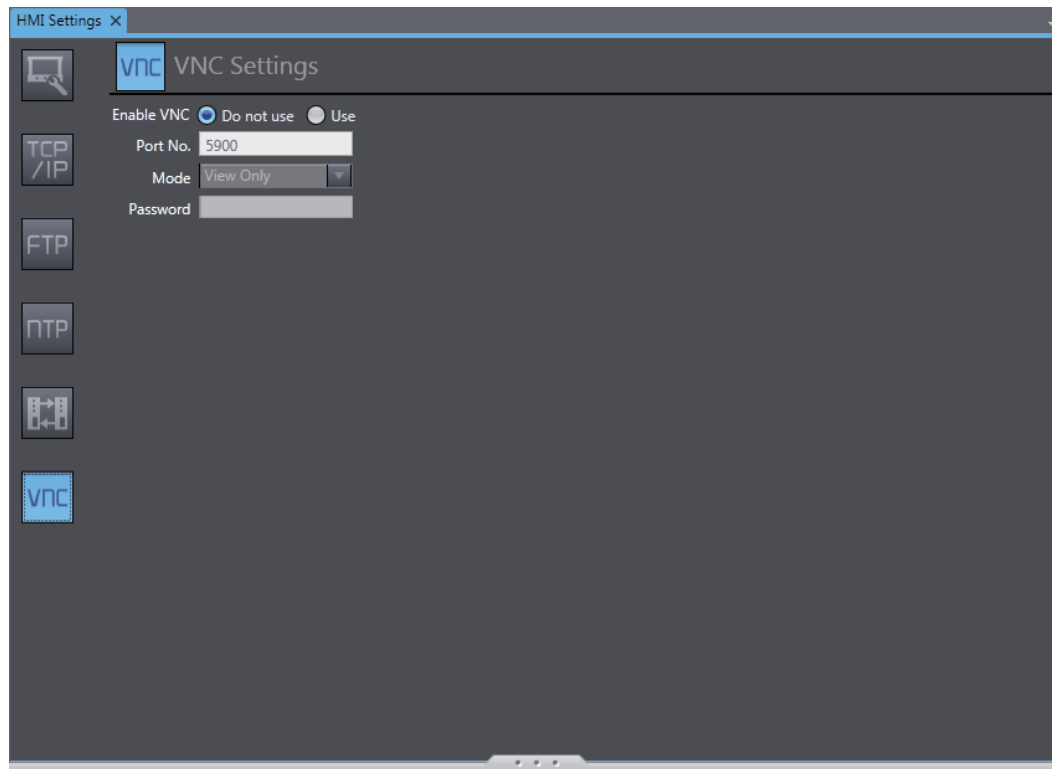

Item	Description
VNC Settings	
Enable VNC	Specifies whether to use VNC.
Port No.	Sets the port number.
Mode	Sets the operations to enable from the VNC client.
Password	Sets the password.

3-5 Security Settings

These settings are used to restrict the operations that can be performed on the HMI and register accounts.

Setting Procedure for Security Settings

- 1 Double-click **Security** under **Configurations and Setup** in the Multiview Explorer. The Security Settings Tab Page appears in the Configurations and Setup Layer.

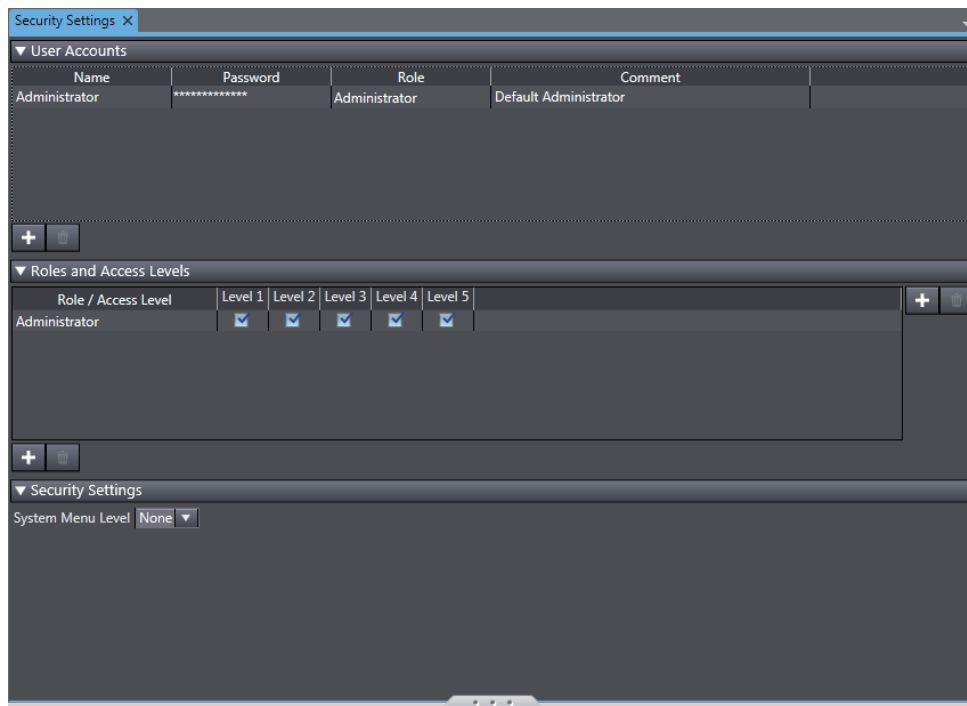

Item	Description
User Accounts	Registers user accounts.
Roles and Access Levels	Sets the access level for each role.
Security Settings	Sets the level of operations to permit from the System Menu.

3-6 Language Settings

These settings are used for multi-language projects.

Project Language and System Language

There are two languages on the HMI.

- **Project Language**
The project language is displayed for the project that you create.
- **System Language**
The system language is displayed for the System Menu and for error messages displayed by the system.

The two language settings are managed as pairs. If you change the project language, the paired system language will also change.

Language Setting Procedure

- 1 Double-click **Language Settings** under **Configurations and Setup** in the Multiview Explorer. The Language Settings Tab Page appears in the Configurations and Setup Layer.

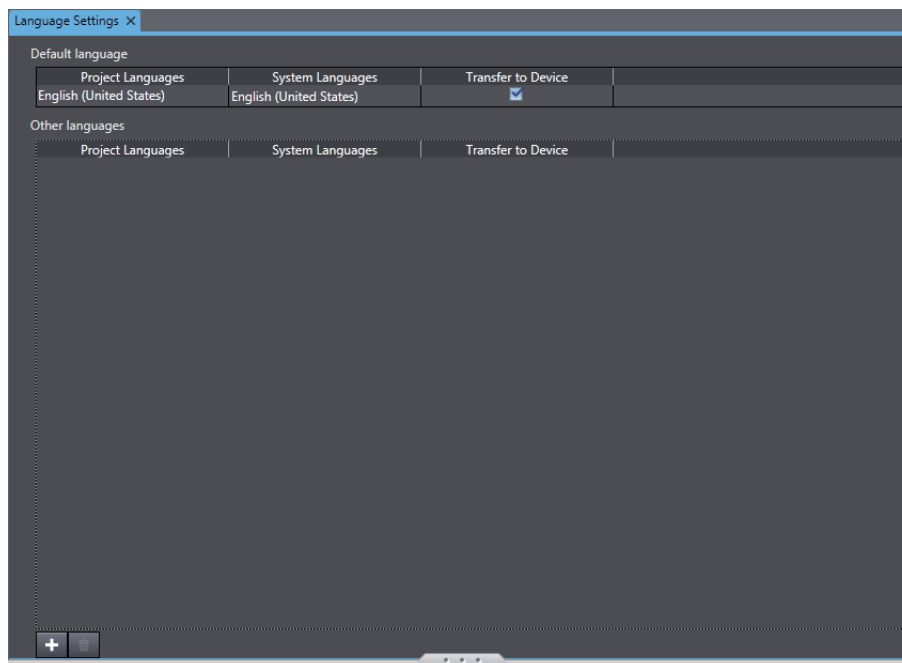

Item	Description
Default language	Sets the language that is displayed by default.
Other languages	Sets the languages to add in addition to the default languages.



Additional Information

You can clear the selection of the *Transfer to Device* Check Box so that the language files are not transferred to the HMI. You can use this to delete unnecessary languages depending on the destination of the HMI.

3-7 HMI Clock

To set the clock in the HMI, select **HMI Clock** from the HMI Menu when you are online. Set the required items and click the **Apply** Button to update the information in the HMI.

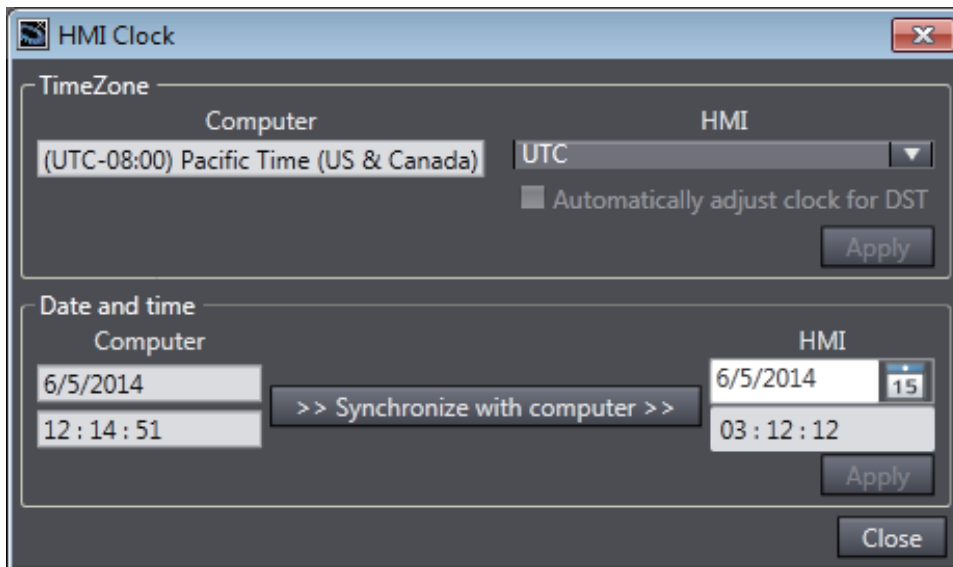

Item	Description
Time Zone	
Computer	Displays the time zone of the computer.
HMI	Sets the time zone of the HMI
Automatically adjust clock for DST	Select this check box to enable automatically adjusting for daylight savings time.
Date and time	
Computer	Displays the current date and time on the computer.
Synchronize with computer	Updates the clock information on the HMI with the clock information from the computer.
HMI	Set the clock information on the HMI.

3-8 Updating the HMI Name

To change the HMI name, select **HMI Name** from the HMI Menu when you are online. A confirmation dialog box is displayed. To update the HMI name that is set in the project, click the **Yes** Button.

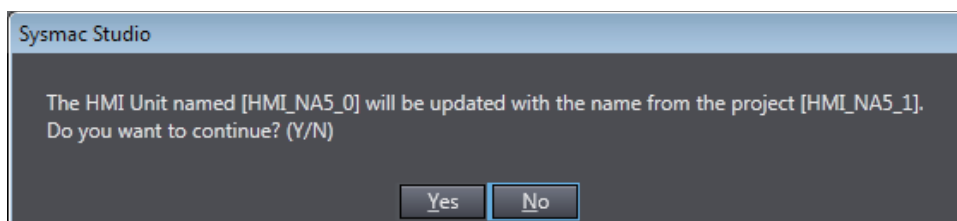

3-9 Write Protecting the HMI

To write-protect the HMI, select **Security - HMI Write Protection** from the HMI Menu when you are online.

A confirmation dialog box is displayed. Click the **Yes** Button to write-protect the HMI.

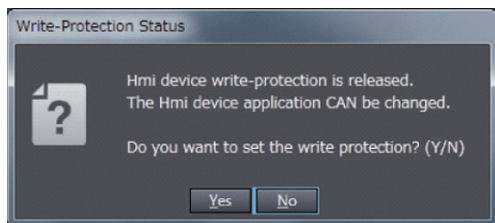

Only the project is write-protected. The project can still log data and write other data.

3-10 Clear All Memory

You can initialize the HMI.

When you perform the Clear All Memory operation, all data is cleared except for time data. To clear all memory in the HMI, select **Clear All Memory** from the HMI Menu when you are online.

A confirmation dialog box is displayed. Click the **OK** Button to clear all memory.

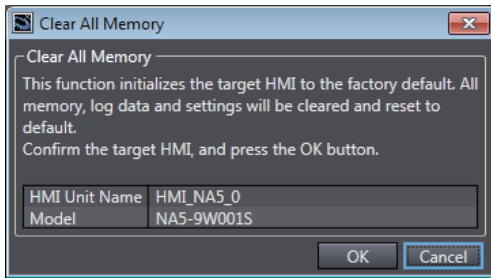

3-11 Resetting the HMI

You can reset the HMI.

To reset the HMI, select **Reset HMI Device** from the HMI Menu when you are online. A confirmation dialog box is displayed. Click the **Yes** Button to reset the HMI.

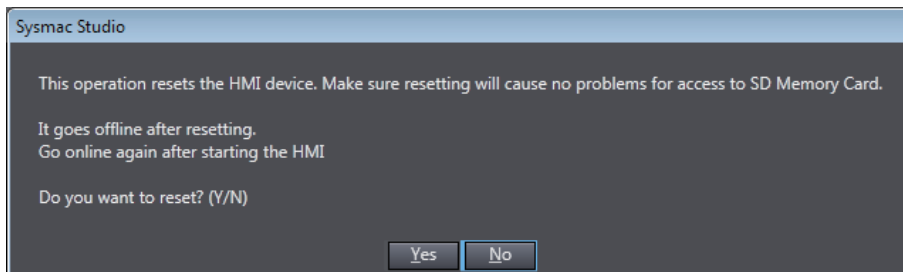

4

Creating the HMI Application

This section describes how to create the HMI application (pages, variables, subroutines, etc.) with the Sysmac Studio.

4

4-1	Registering Variables	4-2
4-1-1	Variables	4-2
4-1-2	Registering Global Variables	4-2
4-1-3	Registering External Variables	4-4
4-1-4	Attributes and Entry Methods for Global Variables	4-5
4-1-5	System-defined Variables	4-8
4-1-6	Subroutine Variables	4-10
4-2	Creating Pages	4-11
4-2-1	Displaying Pages	4-12
4-2-2	Registering Pages	4-12
4-2-3	Page Property Settings	4-14
4-2-4	Editing Pages	4-15
4-3	Setting Common Object Functions	4-18
4-3-1	Registering User Alarms	4-18
4-3-2	Registration for Data Logging	4-20
4-3-3	Registering Recipes	4-21
4-3-4	Setting Global Events and Corresponding Actions	4-22
4-3-5	Registering Global Subroutines	4-24
4-3-6	Setting Up Resources	4-25
4-3-7	Setting Up IAG Resources	4-26
4-4	Subroutines	4-27
4-4-1	Subroutine Execution	4-28
4-4-2	Precautions on Internal Processing	4-31
4-4-3	Code Editor	4-31
4-4-4	Differences in Language Specifications	4-31
4-5	Search and Replace	4-32
4-6	Building	4-33
4-6-1	Building	4-33
4-6-2	Build Operation	4-33
4-7	Offline Comparison	4-34

4-1 Registering Variables

4-1-1 Variables

A variable is a 'container' that holds data.

The HMI supports the following types of variables.

Variable type	Description
Global variables	<p>Global variables are defined by the user and can be accessed from anywhere in the project. You can register up to 35,000 total in the entire project and up to 20,000 for each connected device.</p> <p>Global variables are declared in the HMI global variable table.</p> <p>Global variables include external variables and internal variables, which are described below.</p>
External variables	<p>External variables are global variables that are used to access data in Controllers and other connected devices.</p> <p>External variables are assigned to device variables in the variable mapping.</p>
Internal variables	<p>An internal variable can be used only within the HMI.</p> <p>All global variables that are not external variables are internal variables.</p>
System-defined variables	<p>System-defined variables are provided in advance in the HMI. The names and all attributes are defined by the system. They have specific functions.</p> <p>You cannot change the variable names or any other attributes of these variables.</p>
Subroutine variables	<p>Subroutine variables are defined by the user and are used only within subroutines.</p> <p>Subroutine variables are declared in Dim statements in page subroutines or global subroutines.</p> <p>You can use all of the data types that are supported by Visual Basic.</p>

4-1-2 Registering Global Variables

● Opening the Global Variable Tab Page

Double-click **Global Variables** under **HMI - Data** in the Multiview Explorer. Or, right-click **Global Variables** under **HMI - Data** and select **Edit** from the menu.

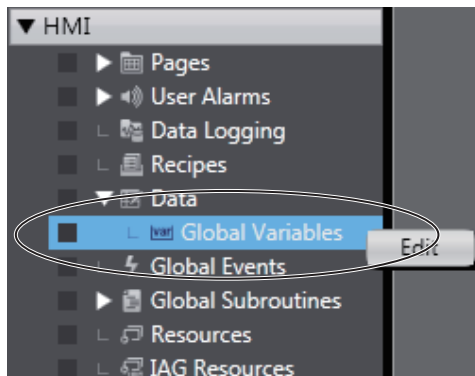

The global variable table is displayed in the HMI Layer.

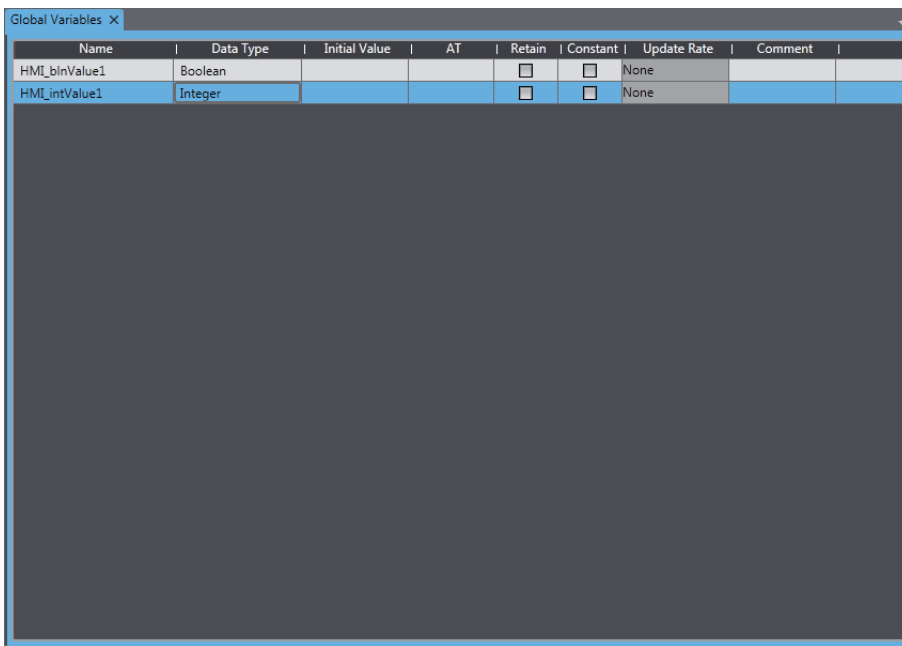

The basic Sysmac Studio operations for the global variable table generally apply to HMIs. Refer to the *Sysmac Studio Version 1 Operation Manual* (Cat. No. W504) for the basic operations.

However, the following items are different. Refer to *4-1-4 Attributes and Entry Methods for Global Variables* on page 4-5.

Item	Description
Name	There are specific prohibited characters that apply to HMIs.
Data Type	There are specific data types for HMIs.
AT	You can set the device variables to which to assign the global variables. This setting is not used for internal variables.
Update Rate	You can select the interval at which to get values from the connected device. This setting is used only for external variables.



Additional Information

Even if you change the name of a previously registered global variable, the name of the variable accessed from objects or subroutines will not change.

4-1-3 Registering External Variables

External Variables

External variables are global variables that are used to access data in connected devices.

Creating External Variables

External variables are created in the variable mapping.

The global variables are mapped to the connected device variables.

In the variable mapping, you can create new variables or you can select variables that were previously created.

If you create a new external variable in the variable mapping, it will automatically be registered as a global variable.

Refer to *3-3 Mapping Variables* on page 3-7 for details on the variable mapping.

Attributes of External Variables

If you create a new external variable in the variable mapping, the following attributes are registered for it in the global variable table.

Refer to *4-1-5 System-defined Variables* on page 4-8 for details on the attributes of variables.

Attribute	Setting	Changes to settings
Name	Specified variable name	Possible.
Data Type	Refer to the <i>NA-series Programmable Terminal Device Connection User's Manual</i> (Cat. No. V119) for details on data type for the HMI global variables based on data types for device variable.	Possible.
Initial Value	None	Not possible.
AT	<i>Device_name.Device_variable_name</i>	Possible.
Retain	Non-retained	Not possible.
Constant	None	Not possible.
Update Rate	500 ms	Possible.
Comment	Specified comment	Possible.

4-1-4 Attributes and Entry Methods for Global Variables

This section describes attributes and entry methods for global variables.

Attributes of Global Variables

● Name Attribute

Name	Data Type	Initial Value	AT	Retain	Constant	Update Rate	Comment
HMI_blnValue1	Boolean		new_Contr...	<input type="checkbox"/>	<input type="checkbox"/>	500 Milliseconds	

Enter a text string for the name. Observe the following restrictions.

- You cannot use any symbols except for underscores.
- The first letter cannot be a number.
- The names are not case sensitive.
- You cannot use names that start with “_HMI”.
- You cannot use names that are reserved for the Sysmac Studio or Visual Basic.
- You cannot use more than 127 characters.

● Data Type Attribute

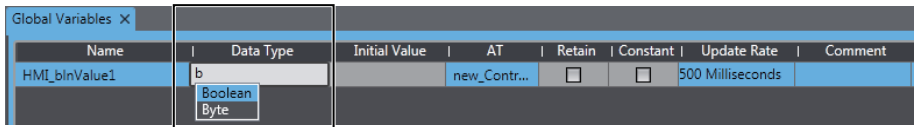

Enter a data type directly or select one from the list.

You can use the following data types, which are supported by Visual Basic. Arrays of the data types that are supported by Visual Basic are also supported. If you specify an array, specify the element number in parentheses after the data type in the same way as in Visual Basic.

Classification	Data type	Data type name	Size	Range of values
Basic data types	Boolean	Boolean	—	True or False
	Byte	Byte	1 byte	0 to 255 (unsigned)
	Char	Char	2 bytes	0 to 65,535 (unsigned)
	Date	Date	8 bytes	0:00:00 (midnight) on January 1, 0001 through 11:59:59 PM on December 31, 9999
	Decimal	Decimal	16 bytes	0 through +/-79,228,162,514,264,337,593,543,950,335 (+/-7.9...E+28) with no decimal point; 0 through +/-7.9228162514264337593543950335 with 28 places to the right of the decimal; smallest nonzero number is +/-0.000000000000000000000000000000001 (+/-1E-28)
	Double	Double	8 bytes	-1.79769313486231570E+308 through -4.94065645841246544E-324 for negative values; 4.94065645841246544E-324 through 1.79769313486231570E+308 for positive values
	Integer	Integer	4 bytes	-2,147,483,648 through 2,147,483,647 (signed)
	Long	Long	8 bytes	-9,223,372,036,854,775,808 through 9,223,372,036,854,775,807 (9.2...E+18) (signed)
	SByte	SByte	1 byte	-128 through 127 (signed)
	Short	Short	2 bytes	-32,768 through 32,767 (signed)
	Single	Single	4 bytes	-3.4028235E+38 through -1.401298E-45 for negative values; 1.401298E-45 through 3.4028235E+38 for positive values
	String	String	Variable length	0 to approximately 2 billion Unicode characters
	UInteger	UInteger	4 bytes	0 through 4,294,967,295 (unsigned)
	ulong	ULong	8 bytes	0 through 18,446,744,073,709,551,615 (1.8...E+19) (unsigned)
ushort	UShort	2 bytes	0 to 65,535 (unsigned)	
Derivative data types	TimeSpan	Structure that gives a time interval		
	Structures	To use structures as global variables, you must import them from a connected device. You can use subroutine variables if you declare them inside the subroutine.		
	Unions	Unions are not supported.		
	Enumerations	Enumerations are supported only in subroutines.		

Refer to the *NA-series Programmable Terminal Device Connection User's Manual* (Cat. No. V119) for information on which of the above HMI variable data types can be assigned to the data types of connected device variables for different connected devices.

● **Initial Value Attribute**

Name	Data Type	Initial Value	AT	Retain	Constant	Update Rate	Comment
HMI_blnValue1	Boolean		new_Contr...	<input type="checkbox"/>	<input type="checkbox"/>	500 Milliseconds	

Specify a value for the variable for one of the following situations when the Retain attribute is not specified.

- When the power supply is turned ON
- When you specify to initialize the value when the project is transferred

Enter a value directly or select an item from the list (the values in the list depend on the data type). If you do not enter an initial value, 0 is used as the initial value.

Select *None* for no initial value. You cannot specify the Initial Value attribute for an external variable.

● **AT Attribute**

Name	Data Type	Initial Value	AT	Retain	Constant	Update Rate	Comment
HMI_blnValue1	Boolean		new_Contr...	<input type="checkbox"/>	<input type="checkbox"/>	500 Milliseconds	

This attribute is specified for external variables. Use the following format.

Device_name.Device_variable_name

● **Retain Attribute**

Name	Data Type	Initial Value	AT	Retain	Constant	Update Rate	Comment
HMI_blnValue1	Boolean		new_Contr...	<input type="checkbox"/>	<input type="checkbox"/>	500 Milliseconds	

Specify whether to retain the value of the variable in the following cases.

- When the power supply is turned ON
- When you do not specify to initialize the value when the project is transferred

You cannot specify the Retain attribute for an external variable.

● **Constant Attribute**

Name	Data Type	Initial Value	AT	Retain	Constant	Update Rate	Comment
HMI_blnValue1	Boolean		new_Contr...	<input type="checkbox"/>	<input type="checkbox"/>	00 Milliseconds	

If you set the Constant attribute, you can set the initial value of the variable when the project is downloaded, but you cannot overwrite the value afterward.

You cannot specify the Constant attribute for an external variable.

● Update Rate Attribute

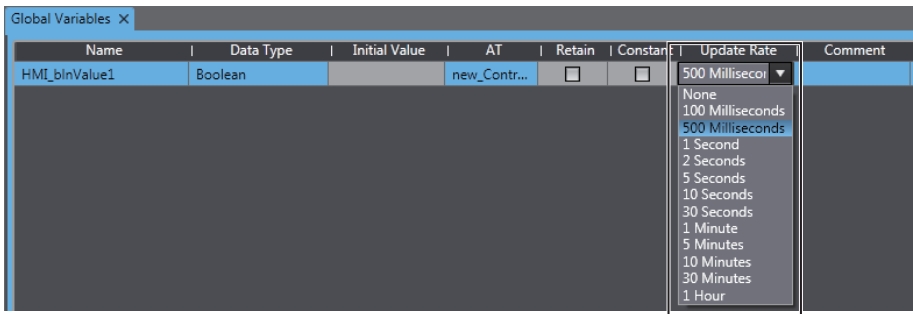

The update interval with the connected device is specified for external variables. If *None* is set for an external variable, the external variable will be treated as an internal variable. In that case, no communications for the variable will be performed with the connected device. You do not need to specify this attribute for an internal variable.

● Comment Attribute

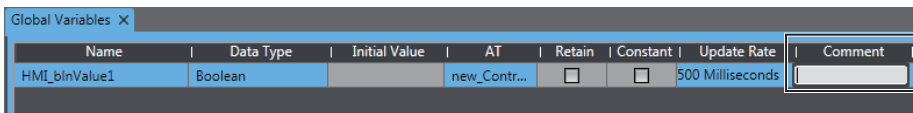

Enter a comment.

4-1-5 System-defined Variables

System-defined Variables

System-defined variables are internal variables that are pre-defined by the system. All system-defined variable attributes are fixed. The names and all other attributes of these variables are defined, and special functions are assigned to them. You cannot change the names or any other attributes.

- You can use the system-defined variables for an HMI as soon as you register an HMI in the project. It is not necessary to register system-defined variables in the global variable table.
- System-defined variables that are related to an HMI start with “_HMI_”.

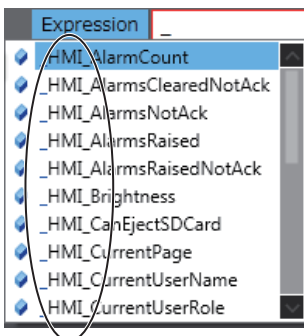

System-defined Variables

● System-related Variables

Variable name	Meaning	Description	Data type	R/W
_HMI_Brightness	Brightness	Sets the brightness of the screen.	Integer	R/W
_HMI_CanEjectSDCard	Can Eject SD Card	Tells whether you can remove the SD Memory Card. True: Ejection is not possible, False: Ejection is possible.	Boolean	R
_HMI_CurrentPage	Current Page Name	Sets the name of the currently displayed page.	String	R/W
_HMI_DateTime	System Time	Gives the system clock time as the local time.	Date-Time	R
_HMI_Hour	Current Hour	Gives the hour in the current time.	Integer	R
_HMI_IsBatteryLow	Low Battery Voltage	Gives True if the battery voltage has dropped below a specific level.	Boolean	R
_HMI_IsDataInput	Data Entry in Progress	Gives True when a data entry object is selected.	Boolean	R
_HMI_IsPageSwitching	Page Switching in Progress	Gives True while page switching processing is in progress and False after processing is completed.	Boolean	R
_HMI_IsScreenSaverActive	Screen Saver Status	Tells whether the screen saver is active. True: Active, False: Not active.	Boolean	R/W
_HMI_ManagedRAMInUse	Usage of Managed RAM	Gives the total bytes of managed RAM that is currently allocated to some process.	ULong	R
_HMI_Millisecond	Current Milliseconds	Gives the milliseconds in the current time.	Integer	R
_HMI_Minute	Current Minutes	Gives the minutes in the current time.	Integer	R
_HMI_RAMInUse	Usage of RAM	Gives the total bytes of RAM that is currently allocated to some process.	ULong	R
_HMI_RAMTotal	Total RAM	Gives the total bytes of RAM that the system is using or can use. This is not the currently usable amount of RAM.	ULong	R
_HMI_RunSignal	Run Signal	Changes periodically while the HMI is operating.	Boolean	R
_HMI_Second	Current Seconds	Gives the seconds in the current time.	Integer	R

● Alarm-related Variables

Variable name	Meaning	Description	Data type	R/W
_HMI_AlarmCount	Alarm Count	Gives the number of alarms that have occurred since startup.	Integer	R
_HMI_AlarmsClearedNotAck	Cleared Unacknowledged Alarms	Gives the number of alarms that are cleared but not acknowledged.	Integer	R
_HMI_AlarmsNotAck	Unacknowledged Alarm Count	Gives the number of alarms that are not acknowledged.	Integer	R
_HMI_AlarmsRaised	Current Alarm Count	Gives the number of current alarms.	Integer	R
_HMI_AlarmsRaisedNotAck	Unacknowledged Current Alarm Count	Gives the number of current alarms that are not acknowledged.	Integer	R

● User and Security

Variable name	Meaning	Description	Data type	R/W
_HMI_CurrentUserName	Current User Name	Gives the name of the user that is currently logged in.	String	R
_HMI_CurrentUserRole	Current User Authority	Gives the authority (role) of the user that is currently logged in.	String	R

4-1-6 Subroutine Variables

Subroutine Variables

Subroutine variables can be used only with subroutines. Subroutine variables conform to Visual Basic specifications.

Refer to the *NA-series Subroutine Reference* for details.

4-2 Creating Pages

One page represents one screen in the HMI project.

You can arrange various objects on a page to achieve the required functions.

There are two types of pages, as described in the following table.

Page Type in the Page Behavior	Sizes (width and height)	Application
Main	Fixed for each model	Basic pages Pages can be layered. You can specify a transparent color and specify a background page.
Popup	You can set the page sizes as long as they are not larger than the main page size.	Warning dialog boxes and other applications

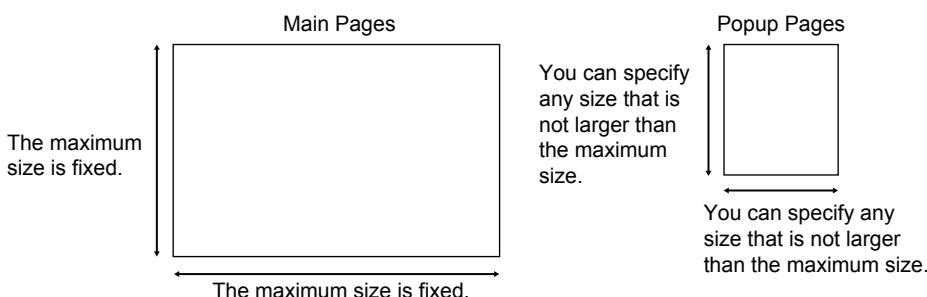

● Main Pages

The main pages are the basic pages. You can create applications to call popup pages from main pages or move to other main pages. You can place up to 450 objects on one main page.

You can create layers of main pages.

You can specify a background page to make the top layer transparent and place a specified page underneath it. You can layer up to five pages including the main pages.

You can create a common page, e.g., with a toolbar, to display with all other pages and then specify it as the background page so that you do not have to create it more than once.

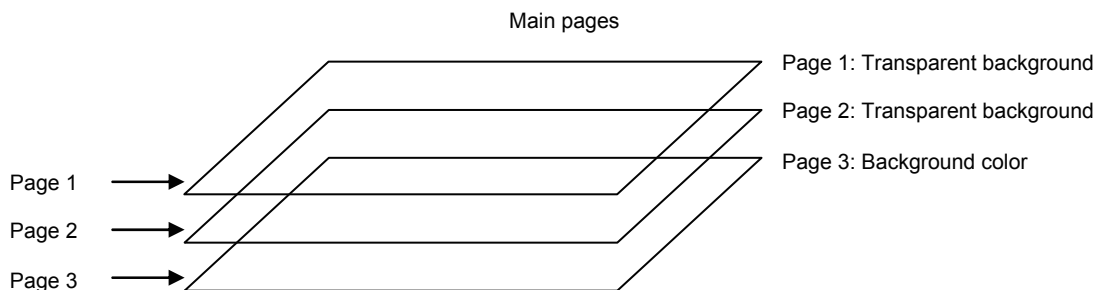

● Popup Pages

Popup pages are called from main pages. Use them to display warnings and other information. You can place up to 450 objects on one popup page. You cannot display more than one popup page at the same time. A popup page is always displayed in the middle of the main page. No operations are possible on the main page while a popup page is displayed.

4-2-1 Displaying Pages

Click **Pages** under **HMI** in the Multiview Explorer.

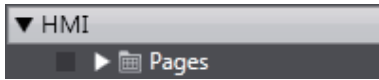

The pages are displayed under **Pages**.

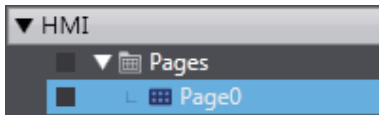

4-2-2 Registering Pages

You can assign various functions to the pages, and use different pages to implement different functions. The project contains one page by default, and you can add more pages as required.

Registering New Pages

- 1 Right-click **Pages** under **HMI** and select **Add - Page** from the menu.

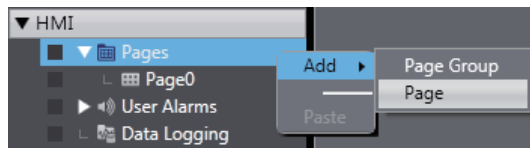

A new page, Page1, is added under **Pages**.

Deleting Pages

- 1 Right-click the page to delete in the Multiview Explorer and select **Delete** from the menu. A deletion confirmation dialog box is displayed.

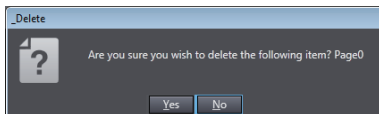

Click the **Yes** Button. The page is deleted.

Copying and Pasting Pages

- 1 Select the page to copy in the Multiview Explorer and press the **Ctrl + C** Keys. Or, right-click the page and select **Copy** from the menu.

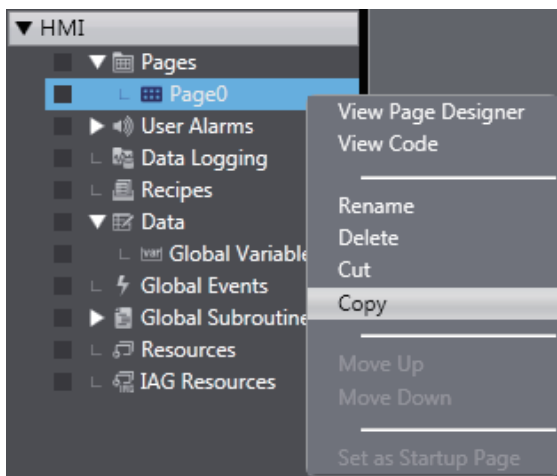

The page is copied.

- 2 Select **Pages** in the Multiview Explorer and press the **Ctrl + V** Keys. Or, right-click **Pages** and select **Paste** from the menu.

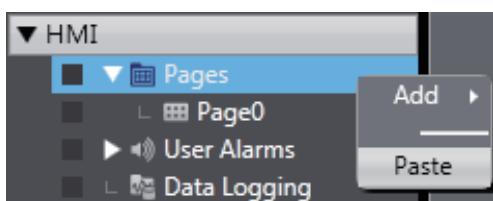

The copied page is registered with “Copy_1_of_” added to the front of the name of the page that was copied. All of the contents of the page are also copied.

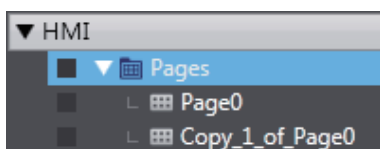

Additional Information

- You can change the names of pages. Right-click the page and select **Rename** from the menu.
- If you copy a page from another product and a page with the same name already exists, the page will be named as a copy.

4-2-3 Page Property Settings

You can set properties for the pages.

Setting Properties

- 1 Right-click in a location in the Edit Pane where there is no object and select **Properties**.
- 2 Set the properties for the page in the Properties Window that is displayed.

Item classification	Item	Setting	Remarks
General	Name	Defaults: Page0, Page1, Page2, etc.	All names must be unique.
	Type	Page (Cannot be changed)	
Appearance	Background Color	Select the color. Default: Black	A transparent page will automatically be set if a background page is specified.
Behavior	PageType	Main or Popup	
	BackgroundPage	Select a previously created page.	A background page can be set only for a main page.
Layout	Size (Width, Height)	The default is the maximum size for the model.	You can change the size if the behavior setting described above is set to a popup. You cannot change the size of main pages.

Click the arrowhead (▼) at the right of each item to make selections.

If you select a popup for the behavior setting, you can increase and decrease the width and height layout sizes with the arrowheads (▲▼) on the right side of the box after first selecting the size to change (left: width, right: height).

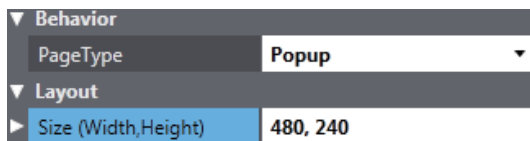

4-2-4 Editing Pages

You can arrange objects on the pages to achieve the required functions.

Positioning Objects

Drag objects from the Toolbox to position them on a page.

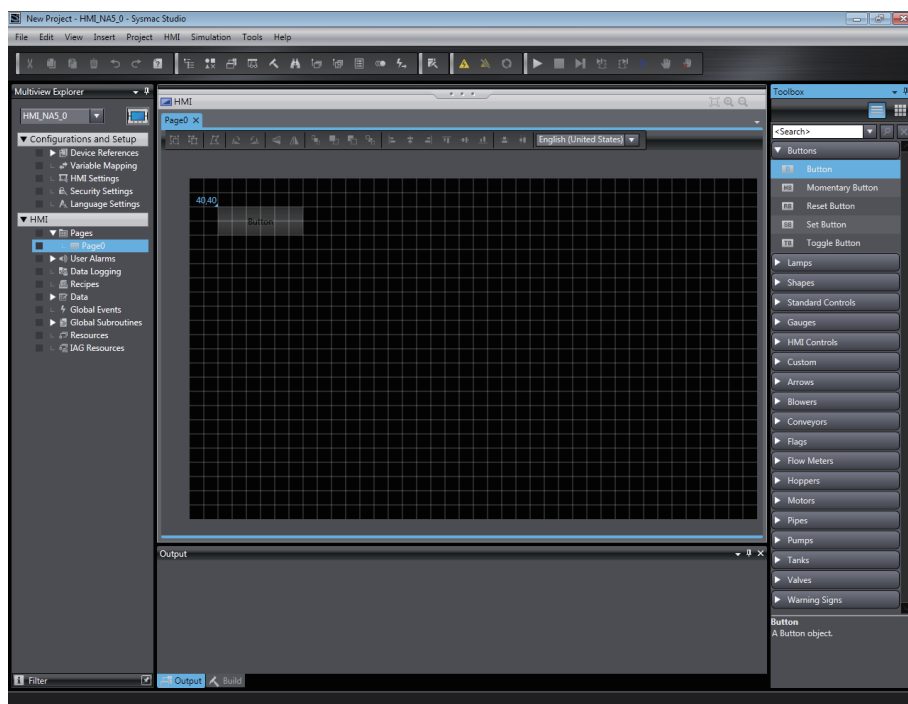

Moving Objects

To move an object, click the object and drag it while the cross cursor is displayed.

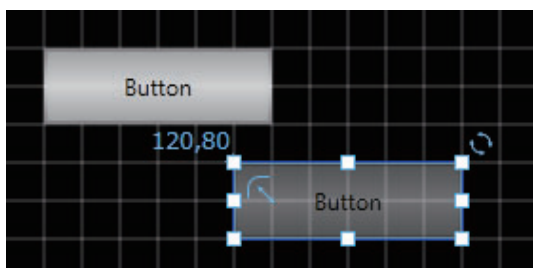

Resizing Objects

Click one of the resize handles around the object and drag it while the resizing cursor is displayed.

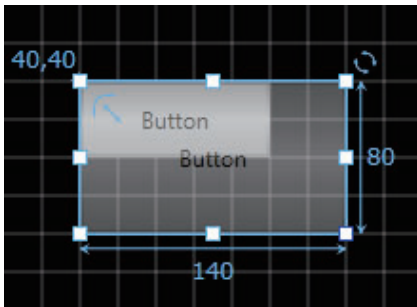

Rotating Objects

Click the rotation handle  to the upper right of the object and drag it while the angle is displayed in the center of the object.

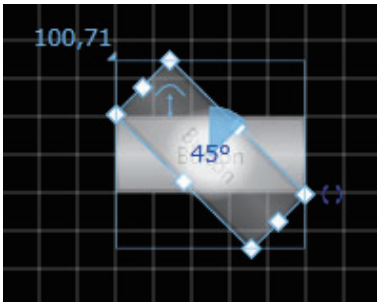

Editing with the Toolbar

The functions that are commonly used to edit pages are provided in the Toolbar.



Group

This button creates a group of objects.



Ungroup

This button ungroups previously grouped objects.



Edit

This button is used to edit graphic objects and other objects.



Rotate Right 90 Degrees

This button rotates an object 90° clockwise.



Rotate Left 90 Degrees

This button rotates an object 90° counterclockwise.



Flip Vertical

This button flips a graphic object vertically.

**Flip Horizontal**

This button flips a graphic object horizontally.

**Bring to Front**

This button moves an object to the front.

**Bring Forward**

This button moves an object toward the front.

**Send Backward**

This button moves an object toward the back.

**Send to Back**

This button moves an object to the back.

**Align Left**

This button aligns the left edges of the selected objects.

**Align Center Vertical**

This button aligns the centers of the selected objects vertically.

**Align Right**

This button aligns the right edges of the selected objects.

**Align Top**

This button aligns the top edges of the selected objects.

**Align Center Horizontal**

This button aligns the centers of the selected objects horizontally.

**Align Bottom**

This button aligns the bottom edges of the selected objects.

**Distribute Horizontally**

This button positions the centers of the objects at equal distances horizontally.

**Distribute Vertically**

This button positions the centers of the objects at equal distances vertically.

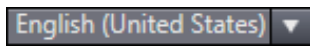
**English (United States) Change Language**

This box changes the project language that is displayed in the Edit Pane.

4-3 Setting Common Object Functions

This section describes the settings for functions that are shared by the entire HMI project.

The following functions are provided.

- User alarms
- Data logging
- Recipes
- Global events
- Global subroutines
- Resources
- IAG resources

4-3-1 Registering User Alarms

User Alarms

You can specify conditions for specified variables to display user messages when the conditions are met.

You can use this to record information when errors occur, when operation is started, etc.

Registering a New User Alarm

You manage user alarms by group.

The groups are displayed in the User Alarms Viewer and are helpful in organizing information.

- 1 Right-click **HMI** under **User Alarms** in the Multiview Explorer and select **Add - Group** from the menu.

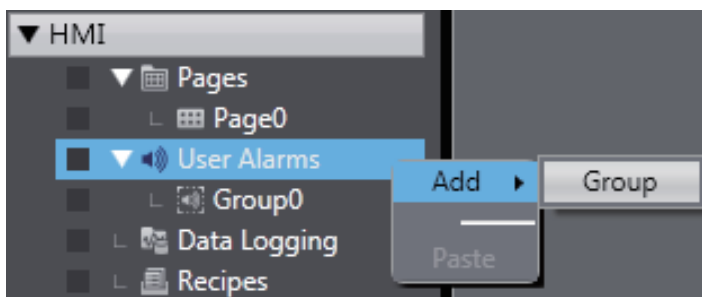

Group1 is added under **User Alarms**.

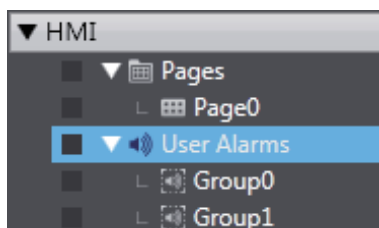

2 Double-click the new group.

A tab page to edit the group is displayed in the HMI Layer of the Edit Pane so that you can register user alarms.

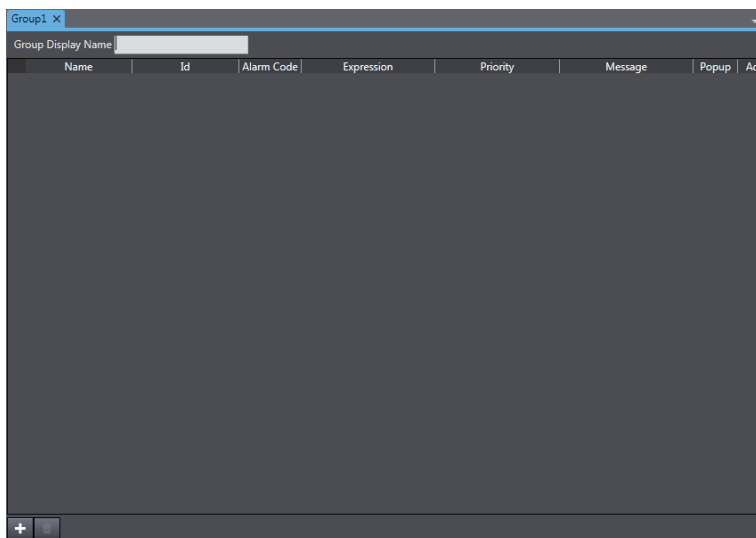

Deleting, Copying, and Pasting Groups

You can delete, copy, and paste groups using the same procedures as those that you use for pages.

4-3-2 Registration for Data Logging

Data Logging

You can use data logging to store the changes in the values of specified variables over time.

You can display the saved data with Trend Graph objects. You can also save this data to external files.

Registering a New Data Set

To log data, you must create one or more data sets. You can create different data sets to change the location where the data is saved.

- 1 Right-click **HMI - Data Logging** in the Multiview Explorer and select **Add - Data Set** from the menu.

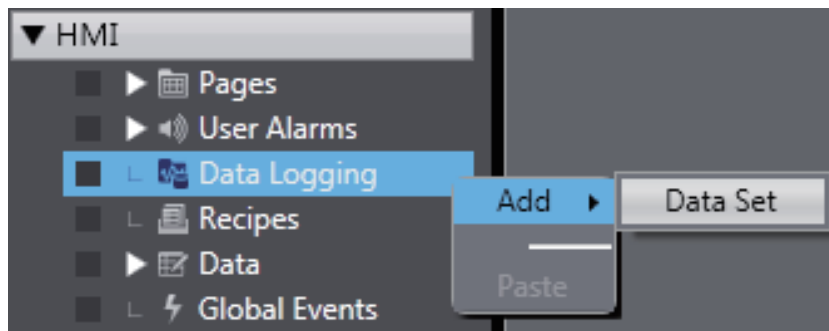

DataSet0 is added under **Data Logging**.

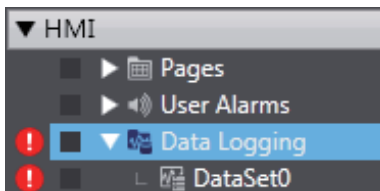

- 2 Double-click the new data set.

A tab page to make settings for the data set is displayed in the HMI Layer of the Edit Pane. You can set the variables to log, the storage locations, and other parameters.

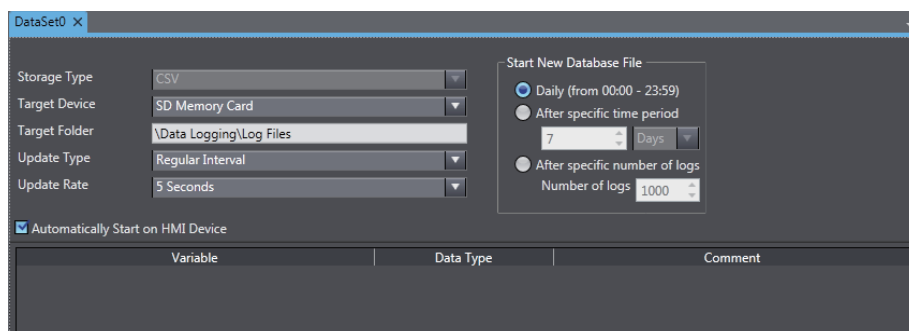

Deleting, Copying, and Pasting Data Sets

You can delete, copy, and paste data sets using the same procedures as those that you use for pages.

4-3-3 Registering Recipes

Recipes

A recipe is used to write data (numeric data or text strings) that was set in advance in the HMI to all of the specified variables as a group or to read all of the specified variables as a group.

You can manipulate the registered recipe data with Recipe Viewer objects.

Registering a New Recipe

To use recipes you must create them.

- 1 Right-click **HMI - Recipe** in the Multiview Explorer and select **Add - Recipe Template** from the menu.

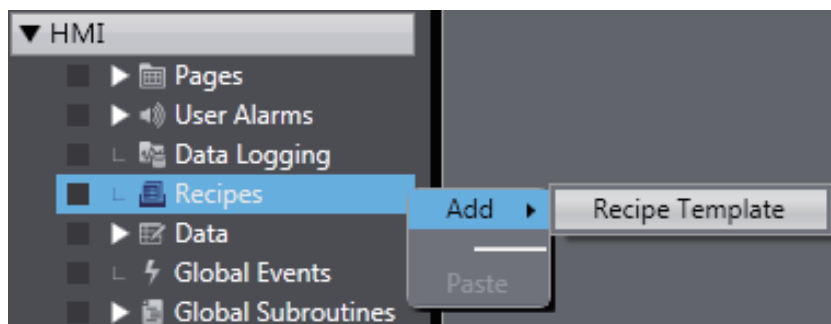

Recipe0 is added under **Recipes**.

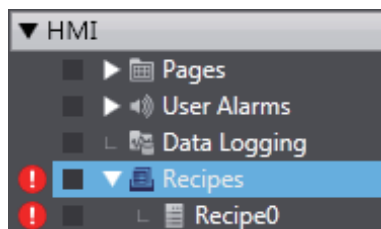

- 2 Double-click the new **Recipe0**. A tab page to make settings for Recipe0 is displayed in the HMI Layer of the Edit Pane. You can set the variables to use and other parameters.

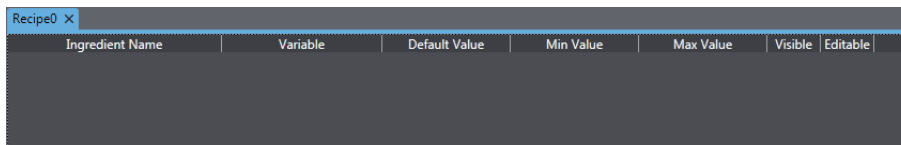

Deleting, Copying, and Pasting Recipes

You can delete, copy, and paste recipes using the same procedures as those that you use for pages.

4-3-4 Setting Global Events and Corresponding Actions

Global Events

Global events occur at the project level and do not belong to any specific page. When a global event occurs, the action that is assigned to the event is executed.

● Global Events

Global events include function key operations, changes in the values of variables, starting the project, etc. A list of the events that you can set is provided in *A-1 Events and Actions* on page A-2.

● Actions

You can specify the action to perform when a global event occurs from a list of predefined actions. Actions include executing global subroutines and other system-defined operations. A list of the actions that you can set is provided in *A-1 Events and Actions* on page A-2.

Setting Up Global Events

To set up a global event, you select the global event and then set the action to execute when the event occurs.

- 1 Right-click **HMI - Global Events** in the Multiview Explorer and select **Edit** from the menu. Or, double-click **HMI - Global Events**.

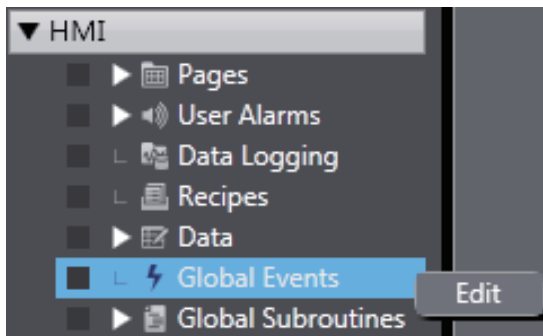

- 2 A tab page to make settings for the global event is displayed in the HMI Layer of the Edit Pane.

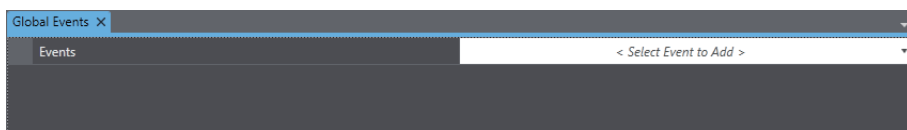

- 3 Click in the column on the right to select the event to set from the event list.

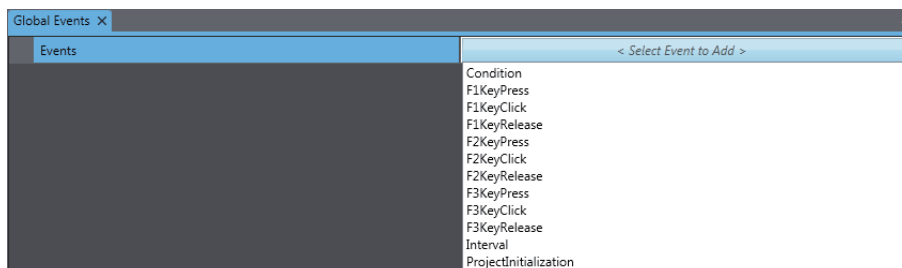

A global event is added.

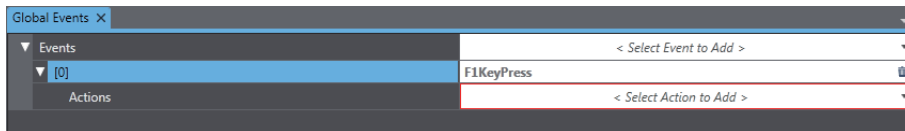

4 In the **Actions** row below the new global event, click in the right column and select the action to perform for the event from the action list.

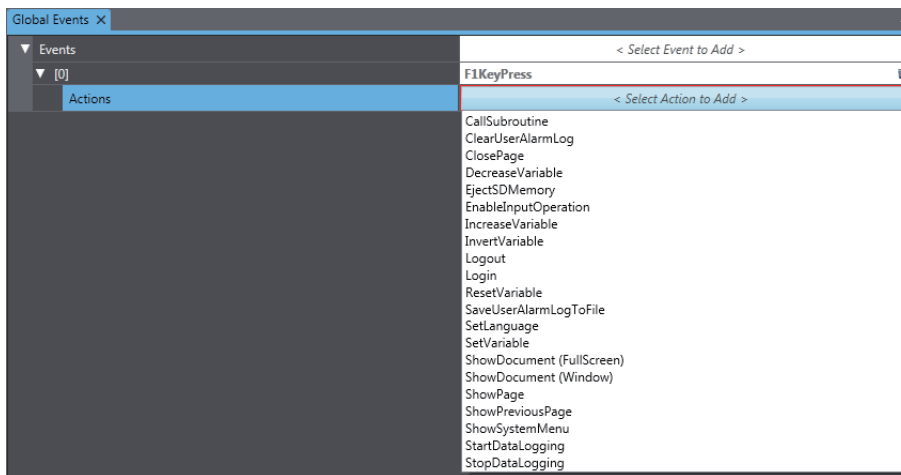

5 When you add global events, they are numbered serially from 0 in the order that you add them.

Deleting Global Events

To delete all of the settings for global events, right-click the **Events** header at the top and select **Reset**.

To delete an individual event, click the  Button on the right edge of the event.

4-3-5 Registering Global Subroutines

Global Subroutines

You can register global subroutines, which you can then call from anywhere in the project.

You can register common subroutines that do not rely on page conditions to make subroutines easier to maintain.

Registering a New Subroutine Group

To register global subroutines, you must create one or more subroutine groups. You can use subroutine groups to separate subroutines by purpose.

- 1 Right-click **HMI - Global Subroutines** in the Multiview Explorer and select **Add -Group** from the menu.

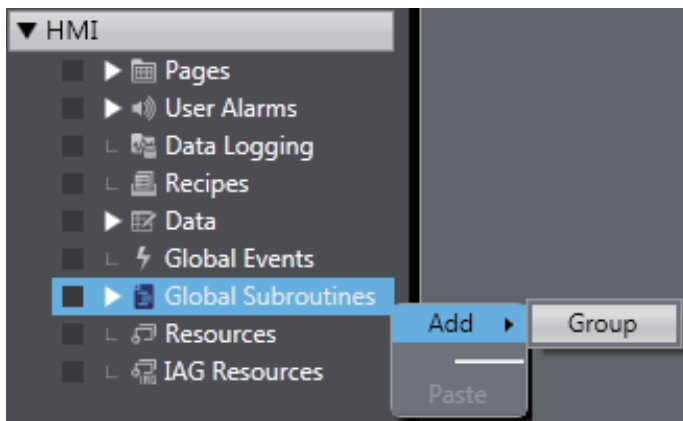

SubroutineGroup1 is added under **Subroutine Groups**.

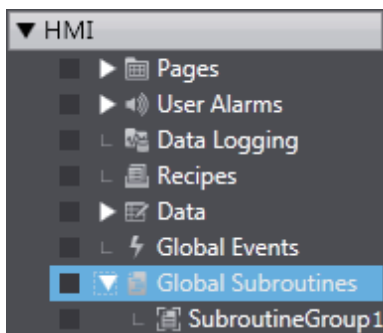

- 2 Double-click the new subroutine group. A tab page for the Code Editor is displayed in the HMI Layer of the Edit Pane.

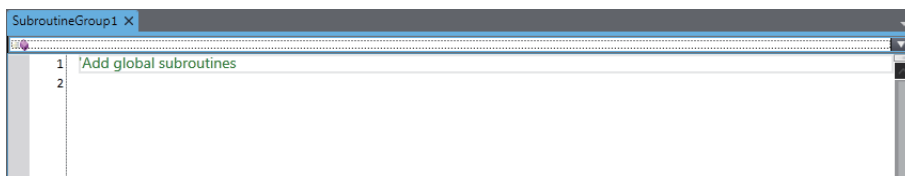

Deleting, Copying, and Pasting Subroutine Groups

You can delete, copy, and paste subroutine groups using the same procedures as those that you use for pages.

4-3-6 Setting Up Resources

Resources

Resources are the text strings, movies, still images, and documents that are displayed for objects and alarms on user pages.

You can use **Resources** to manage all of the text strings, images, files, and other resources that you use in a project.

For multi-language projects, you can set resources for each project language.

Setting Up Resources

To set up a resource, select the resource to set up and then make the settings.

- 1 Right-click **HMI - Resources** in the Multiview Explorer and select **Edit** from the menu. Or, double-click **HMI - Resources**.

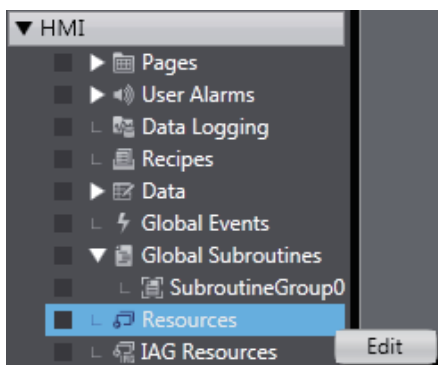

- 2 A tab page to make settings for resources is displayed in the HMI Layer of the Edit Pane. You can select the resource to set and make the settings.

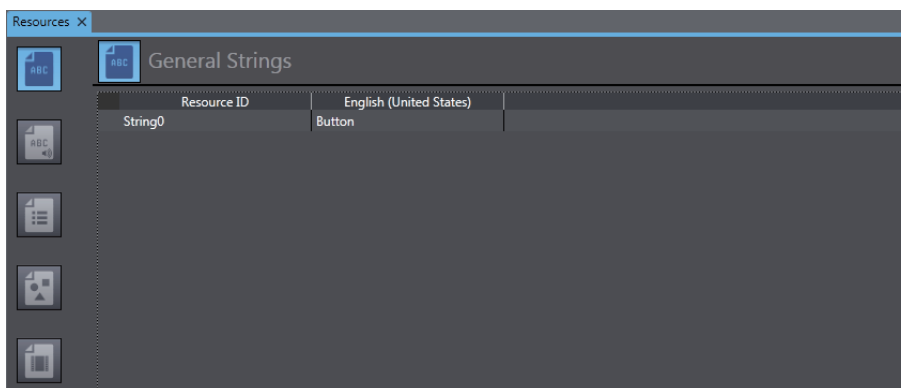

4-3-7 Setting Up IAG Resources

IAG Resources

IAG resources are used within IAGs on user pages. When you place an IAG on a page, the resources for the IAG are automatically registered.

The languages that are displayed by the IAG resources are determined by the project languages. The resources that are set in advance for the IAGs are displayed for the IAG resources. If a language that is not included in an IAG is set as a project language, the resources will be blank by default.

Setting Up Resources

To set up an IAG resource, select the IAG resource to set up and then make the settings.

- 1 Right-click the IAG resource to edit under **HMI - IAG Resources** in the Multiview Explorer and select **Edit** from the menu. Or, double-click the IAG resource.

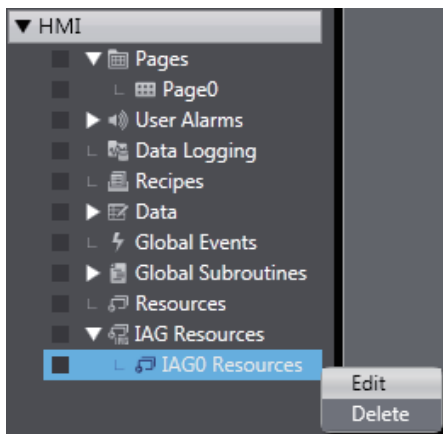

- 2 A tab page to make settings for IAG resources is displayed in the HMI Layer of the Edit Pane. The procedures are the same as for other resources, but you can change only the contents of the resources that are in the IAGs.

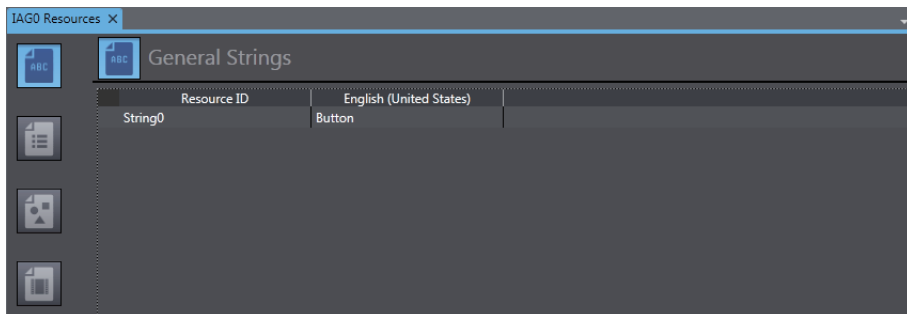

4-4 Subroutines

Subroutines

Subroutines are Visual Basic programs that the user can create. You create subroutines under **Subroutines** in the HMI project.



Precautions for Correct Use

This manual describes only aspects that are different from the specifications standardized by Microsoft Corporation. For any specifications not given in this manual, refer to commercially available reference materials.

Subroutines

There are global subroutines and page subroutines, as described below.

- **Global Subroutines**

Global subroutines are shared by the entire project.

You create global subroutines under **Global Subroutines** in the HMI project. You set CallSubRoutine as the action in a global event, object event, or user alarms event to call a global subroutine.

You can also call a global subroutine from a page subroutine or from another global subroutine.

- **Page Subroutines**

Page subroutines are specific to one page.

You create page subroutines with the Code Editor for a page in the HMI project.

You can directly create the subroutines to execute in the events for individual objects on pages.

4-4-1 Subroutine Execution

You can execute subroutines in the following ways.

- Execution from Global Events
You can execute a global subroutine from a global event.
- Execution from Page and Object Events
You can execute a page subroutine or global subroutine from a page or object event.
- Execution from User Alarm Events
You can execute a global subroutine from a user alarm event.

Execution from Global Events

The following example shows how to use a global event to execute a global subroutine.

In this example, settings are made to execute the global subroutine when the F1 Key is pressed.

- 1 Display the global events and select *F1KeyPress* as the event.

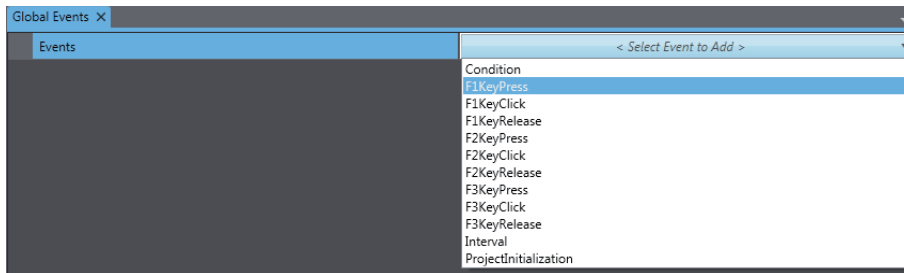

- 2 Select *CallSubRoutine* as the action.

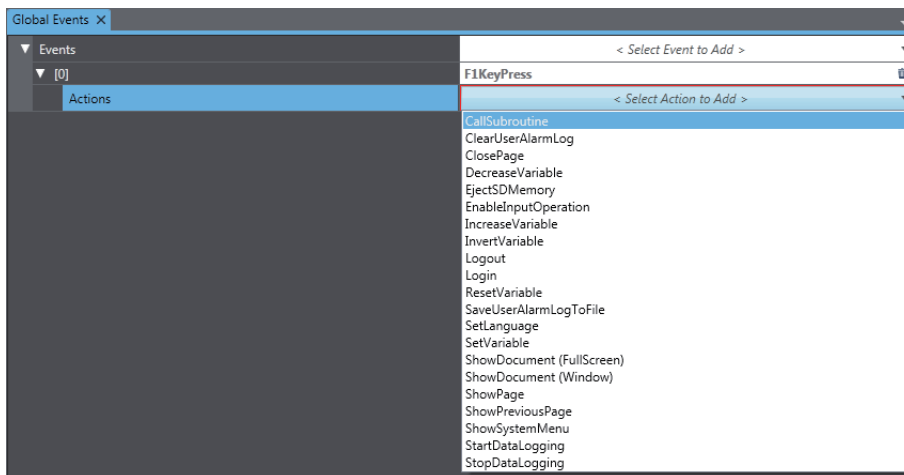

- 3 For the subroutine name, specify the name of a previously created subroutine in the following format: *Subroutine_group.Subroutine_name*

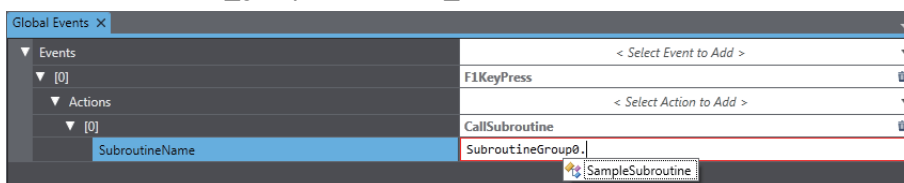

Execution from Objects

The following example shows how to use an object event to execute a subroutine. In this example, settings are made to execute the subroutine when a Button object is pressed.

- 1 Select the Button object and display the events and actions.

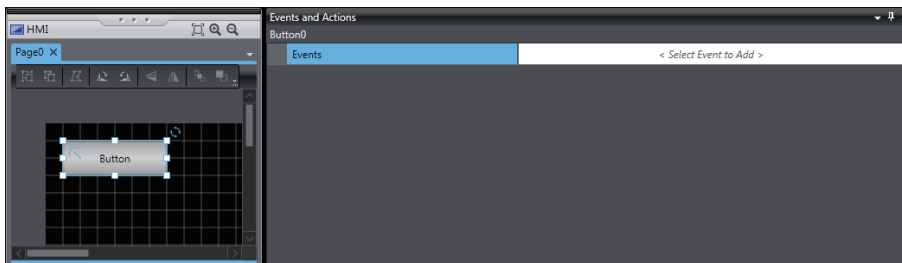

- 2 Select *Press* as the event.

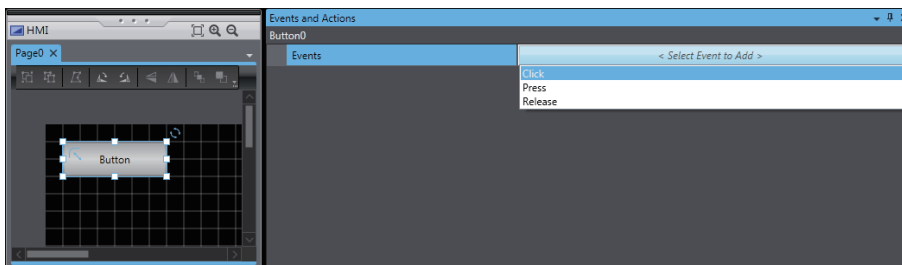

- 3 Select *CallSubRoutine* as the action.

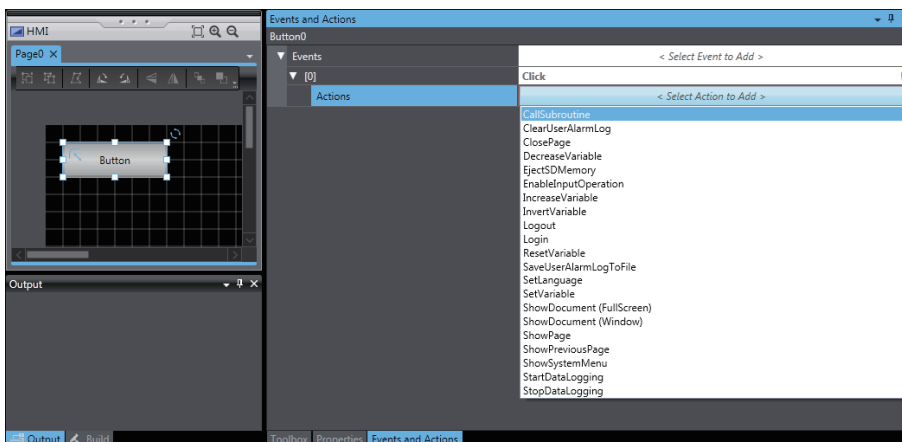

- 4 Specify the subroutine to execute in the following format: *Subroutine_group.Subroutine_name*

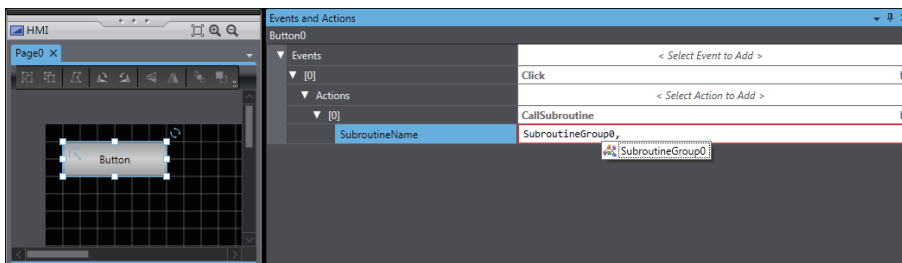

Execution from User Alarms

The following example shows how to use a user alarm event to execute a subroutine.

In this example, settings are made to execute the subroutine when the user alarm occurs.

- 1 Select the user alarm and display the events and actions.

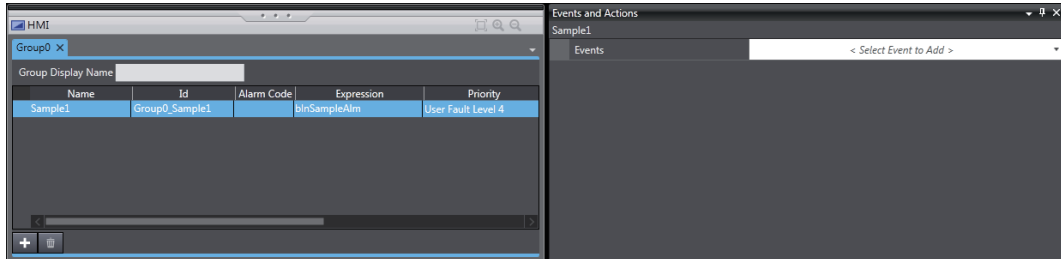

- 2 Select *Raised* as the event.

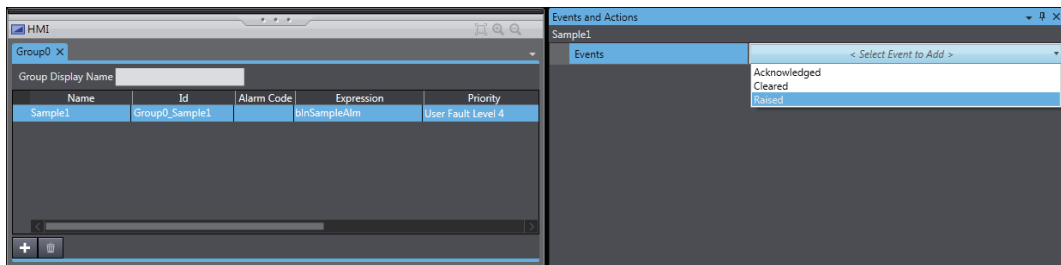

- 3 Select *CallSubRoutine* as the action.

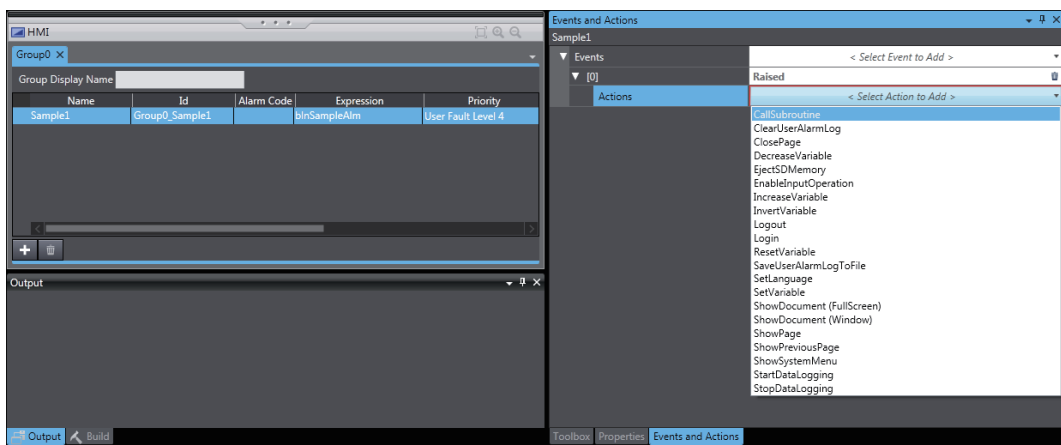

- 4 Specify the subroutine to execute in the following format: *Subroutine_group.Subroutine_name*

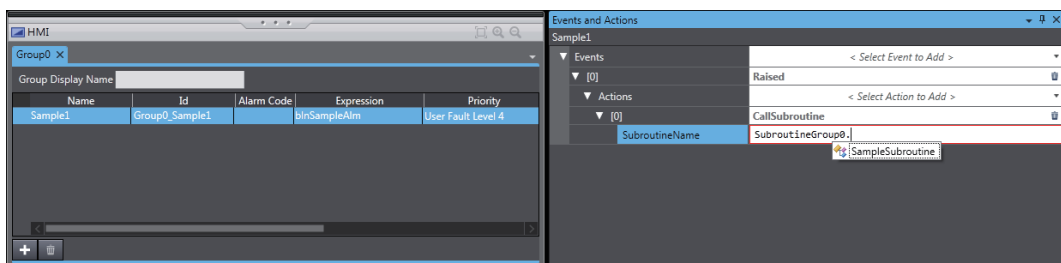

4-4-2 Precautions on Internal Processing

● Handling of Variables

If the value of an external variable is changed in a subroutine, the change is immediately updated at the connected device. Therefore, if you frequently change the value of an external variable inside a subroutine, the performance of that subroutine will be reduced.

● Processing during Subroutine Execution

The touch panel and function keys will not respond during execution of a page subroutine. If you execute processing that requires time, the HMI will not perform other operations until the processing is completed. Consider the execution time when you create subroutines. However, processing will continue for background operations, such as communications, and for page refreshing.

● Simultaneous Execution of Subroutines

It is possible that a subroutine for a global event and a page subroutine will be executed simultaneously. If both subroutines manipulate the same variable, implement exclusive control or other suitable measures.

4-4-3 Code Editor

Subroutines are edited with the Code Editor.

Starting the Code Editor

● Global Subroutines

Double-click a previously registered subroutine under **HMI - Global Subroutines** in the Multiview Explorer. Or, right-click the subroutine and select **Edit** from the menu.

● Page Subroutines

Right-click a previously registered page name under **HMI - Pages** in the Multiview Explorer and select **View Code** from the menu.

Code Editor Features

The Code Editor provides functions equivalent to those of a standard text editor. It also provides functions that are optimized for Visual Basic, such as keyword highlighting, entry assistance, and collapsing Sub statements.

4-4-4 Differences in Language Specifications

Although subroutines are used in Visual Basic, some of the functions are restricted for HMIs. There are also extensions that are provided for use with HMIs. Refer to the *NA-series Subroutine Reference* for details.

4-5 Search and Replace

You can search and replace strings in the data of an HMI subroutine. The basic Sysmac Studio operations for searching and replacing generally apply to HMIs. Refer to the *Sysmac Studio Version 1 Operation Manual* (Cat. No. W504) for details.

Differences When an HMI Is Selected

The following differences apply when an HMI is selected.

- The *Look at what* Box can be set only to *Programming*, i.e., only the contents of the subroutine is searched.
- You can select only *All* for the *Look at* Box.

4-6 Building

4-6-1 Building

The project must be built to convert it into a form that the HMI can execute. During the building process, subroutines and variables are checked.

If there are any errors, the build operation is not performed and  is displayed next to the program or variable where the error occurred in the Multiview Explorer.

You can confirm the errors on the Build Tab Page.

4-6-2 Build Operation

Use the main menu to execute the build operation. HMI projects are not built automatically even if no operations are performed for 5 seconds.

Executing a Build Operation

- 1 Select **Build HMI** from the Project Menu.

Aborting a Build Operation

No functions can be executed while building the project is in progress. If necessary, you can abort building to check the project.

- 1 Select **Abort Build** from the Project Menu.

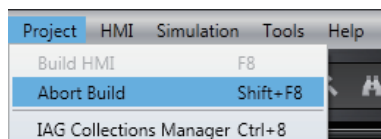

- 2 The build operation is aborted and a message that says it was aborted is displayed in the Output Tab Page.

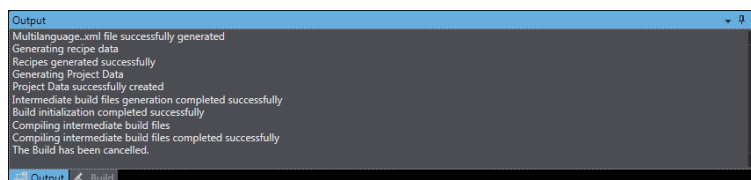

4-7 Offline Comparison

HMI projects are not included in offline comparisons. Even if you perform an offline comparison for a project that contains an HMI as a device, information on the HMI is not included in the comparison results.

5

Objects

This section describes the objects that are provided as standard features.

5-1	Objects	5-2
5-1-1	Object List	5-2
5-1-2	Object Attributes	5-3
5-1-3	Using Objects	5-7
5-2	Examples of Using Objects	5-11
5-2-1	Displaying a PDF File	5-11
5-2-2	Displaying a User Alarm	5-13
5-2-3	Displaying a Trend Graph	5-15
5-2-4	Using a Recipe	5-17

5-1 Objects

Basic objects are provided in the Sysmac Studio as standard features. You can use these objects to easily create pages.

5-1-1 Object List

The following objects are provided.

Functional Objects

A functional object provides some sort of function by itself.

Classification	Object name	Description
Buttons	Button object	Used to execute an action without writing a value to a variable.
	Momentary Button object	Used to change the value of the specified variable to True only while the object is being touched.
	Set Button object	Used to change the value of the specified variable to True when the object is touched.
	Reset Button object	Used to change the value of the specified variable to False when the object is touched.
	Toggle Button object	Used to toggle the value of the specified variable between True and False when the object is touched.
Lamps	Bit Lamp object	Lit while the result of the condition expression is True.
	Data Lamp object	Used to change the color of the lamp according to the value of a condition expression.
Standard controls	CheckBox object	Used to change a variable to True or False depending on whether the check box is selected. Also, the check box can be displayed when the value of the specified variable changes.
	Data Display object	Used to display numeric values or text strings.
	Data Edit object	Used to display and enter numeric values or text strings.
	DateTime object	Used to display the value of a variable as a date and time.
	DropDown object	Used to store the value that corresponds to the item selected in a drop-down list in a variable. Also, the item that corresponds to the specified variable value is displayed.
	Image object	Used to display an image. Refer to <i>A-2 Supported Formats</i> on page A-4 for the supported formats.
	Label object	Used to display a fixed text string. Also, if you use DisplayValue for the animation property, you can display the value of the variable.
	ListBox object	Used to store the value that corresponds to the item selected in a list in a variable. Also, if the value of the specified variable is changed, you can move the focus to an item that corresponds to the new value of the variable.
	Radio Button object	Used to set the specified variable to the value that was set for the selected button. Only one of the specified group of buttons can be selected. Also, the option button can be displayed when the value of the specified variable changes.
	Slider object	Used to set the specified variable to the value that corresponds to the position of the slider. Also, if the value of the specified variable is changed, you can move the slider to the position that corresponds to the new value.
	TextBox object	Used to display a fixed text string. A TextBox object differs from a Label object in that the text string in a TextBox object will wrap.

Classification	Object name	Description
Gauges	Gauge Object	There are several types of gauges provided, such as one with a needle that rotates in a circle and one with a needle that moves in a straight line.
HMI controls	Media Player object	Used to create an object that plays video. Refer to <i>A-2 Supported Formats</i> on page A-4 for the supported formats.
	Recipe Viewer object	Used to display the contents of a recipe.
	Trend Graph object	Used to display data from data logging as a graph.
	User Alarms Viewer object	Used to display a user alarm.

Graphic Objects

A graphic object does not provide any specific function by itself. You must add functions by using events and actions. Many different graphic objects are available. Some typical ones are described in the following table.

Classification	Object name	Description
Shapes	Curve object	Used to draw a curved line. You can double-click the graphic object to edit it.
	Ellipse object	Used to draw a circle or ellipse.
	Line object	Used to draw a straight line. You can double-click the graphic object to edit it.
	Polygon object	Used to draw a polygon. You can double-click the graphic object to edit it.
	Polyline object	Used to draw connected straight lines. You can double-click the graphic object to edit it.
	Rectangle object	Used to draw a rectangle.
	Triangle object	Used to draw a triangle. You can double-click the graphic object to edit it.

5-1-2 Object Attributes

There are the following three types of attributes for objects.

- Properties
- Animations
- Events and actions

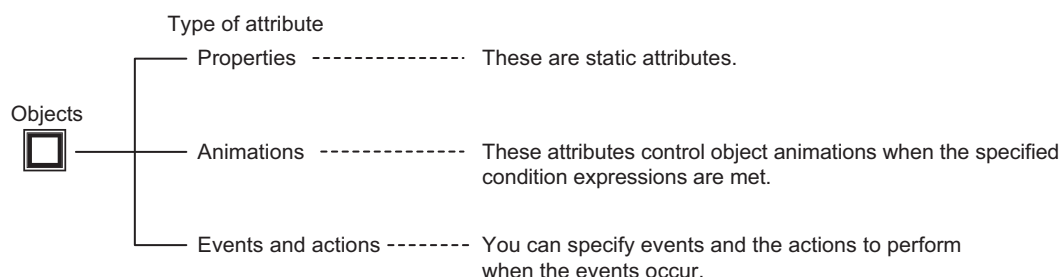

Properties

● Properties

Properties are the static attributes of an object.

These include settings for the names and other general properties, colors, positioning, and other display properties, and assigned condition expressions or variables, as described in the following table.

Properties

Properties	Description
General	You can set the name of the object and check the object type.
Appearance	You can set the object color, shape, label, etc.
Behavior	You can set condition expressions, variables, and delay times to assign to the object.
Expression	You can specify a condition expression that uses variables.
Variable	You can specify a variable.
IsEnabled, DoubleTouch-Time, OnDelayTime, etc.	You can make settings to enable the object, determine the double-touch interval, set the ON-delay time, etc.
Layout	You can set the position and size of the object.
Security	You can set security for the object.
Pointer Marker	You can set the needle marker for a gauge.
Ranges	You can set the range for a gauge.
Scale Bar	You can set the scale bars for a gauge.
Tick Label	You can set scale labels for a gauge.
Tick Major	You can set the major scale division labels for a gauge.
Tick Minor	You can set the minor scale division labels for a gauge.
Needle	You can set the needle for a gauge.
Needle Cap	You can set the needle cap for a gauge.
Data	You can set the data set for data logging.
Left Axis	You can set the left axis for a graph.
Right Axis	You can set the right axis for a graph.
Time Scale	You can set the time axis for a graph.

● Notation for *Expression*

If you specify a BOOL variable, e.g., for a Lamp object, you can specify an expression for the Behavior property.

Examples of the expression notations are given below.

Example 1: Executing a Function when a Boolean Variable (*blnSample* in this Example) Is True

`blnSample=True`

Example 2: Executing a Function when an Integer Variable (*intSample* in this Example) Is Less Than 20

`intSample<20`

Example 3: Executing a Function when a Boolean Variable (*blnSample* in this Example) Is True and an Integer Variable (*intSample* in this Example) Is Less Than 20.

`(blnSample=True) AND (intSample<20)`

Example 4: Setting a Value by Adding 100 to an Integer Variable (*intSample* in this Example)

`intSample+100`

● Notation for *CustomDisplayFormat*

If you set *DisplayFormat* to *Custom* for a Data Display object, you must set the custom display format (*CustomDisplayFormat*). The basic format is `0:*****`, where `*****` is replaced with the result of *Expression*.

This format follows the specifications of custom numeric format strings in Visual Basic. For details, refer to the Microsoft website or to commercially available reference materials.

Example 1: Display When Result of Expression is 1.234 and `{0:00.0000}` Is Specified

01.2340

Example 2: Display When Result of Expression is 1.234 and `{0:##.####}` Is Specified

1.234

Example 3: Display When Result of Expression is 1.234 and `X={0:##.####}` Is Specified

X=1.234

Animations

● Animations

You can use animations to change the status of the object according to *Expression* (condition expression).

As described below, you can specify the status when the condition expression is met, such as flashing, enabling/disabling operation, size/coordinate changes, and displaying/hiding the object.

Animation List

Animation name	Description
Blink	When the condition expression is met, the object flashes in the specified color.
ColorChange(Analog)	Changes the color of the object according to a value.
ColorChange(Boolean)	Changes the color of the object according to True/False status.
DisplayValue	Displays a value based on a condition expression.
Enable	Enables operating the object when the condition expression is met.
Move	Changes the coordinates of the object according to specified condition expressions.
PercentageFill	Fills a graphic figure based on a condition expression and a percentage between the upper and lower limits.
ResizeHeight	Changes the height of the object according to a specified condition expression.
ResizeWidth	Changes the width of the object according to a specified condition expression.
Rotate	Rotates a graphic object based on a condition expression.
Visibility	Displays the object when a condition expression is met.

Events and Actions

● Events and Actions

You can make settings for object events and corresponding actions.

You can specify events and the actions to perform when the events occur.

You can specify the required conditions and operations, such as executing a specified subroutine when a function key is touched.

The events and actions are listed in *A-1 Events and Actions* on page A-2.

5-1-3 Using Objects

The objects are provided in the Toolbox on the right side of the window.

You can create them on pages and set the properties and animations and also the events and actions.

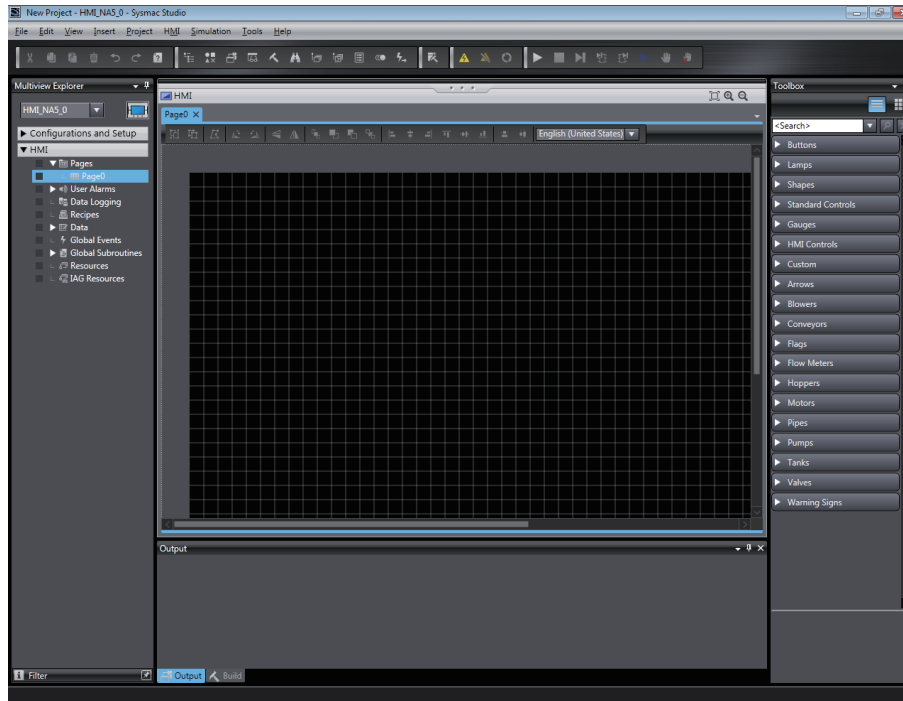

Creating Objects

- 1 Drag the objects from the Toolbox and drop them on the page.

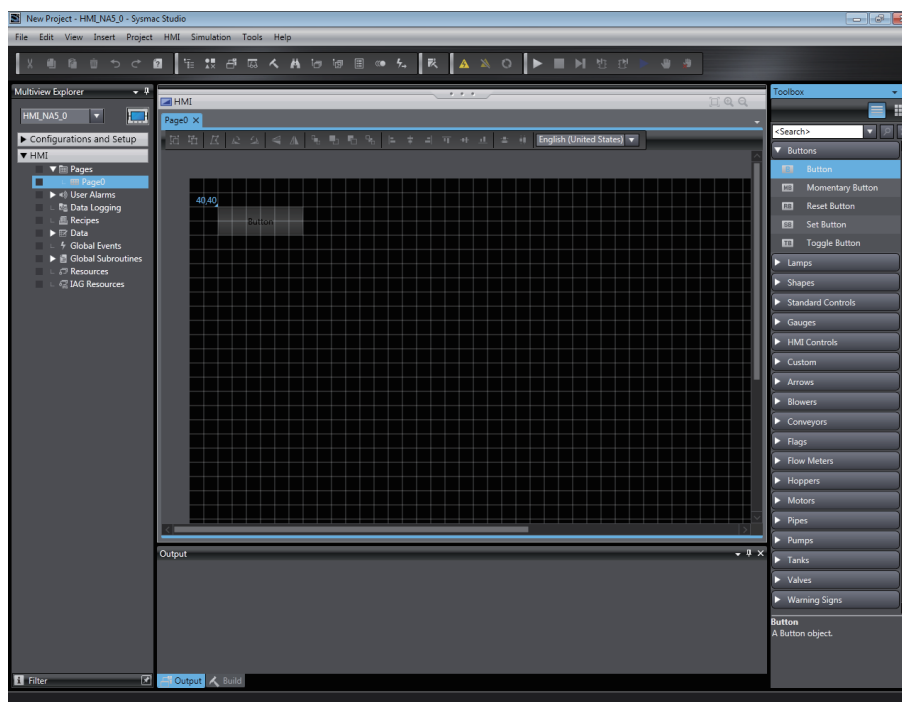

Setting Properties

- 1 Select **Properties** from the View Menu.

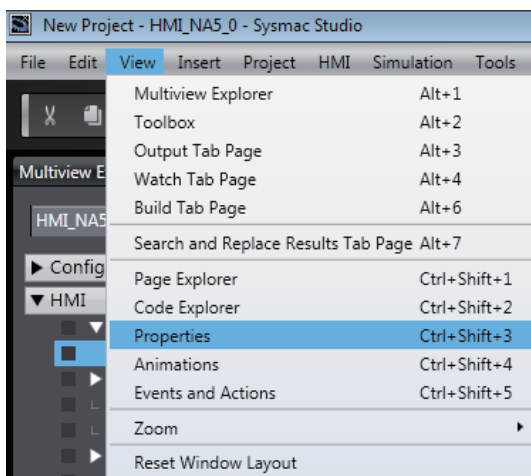

- 2 The properties are the static attributes of the objects.

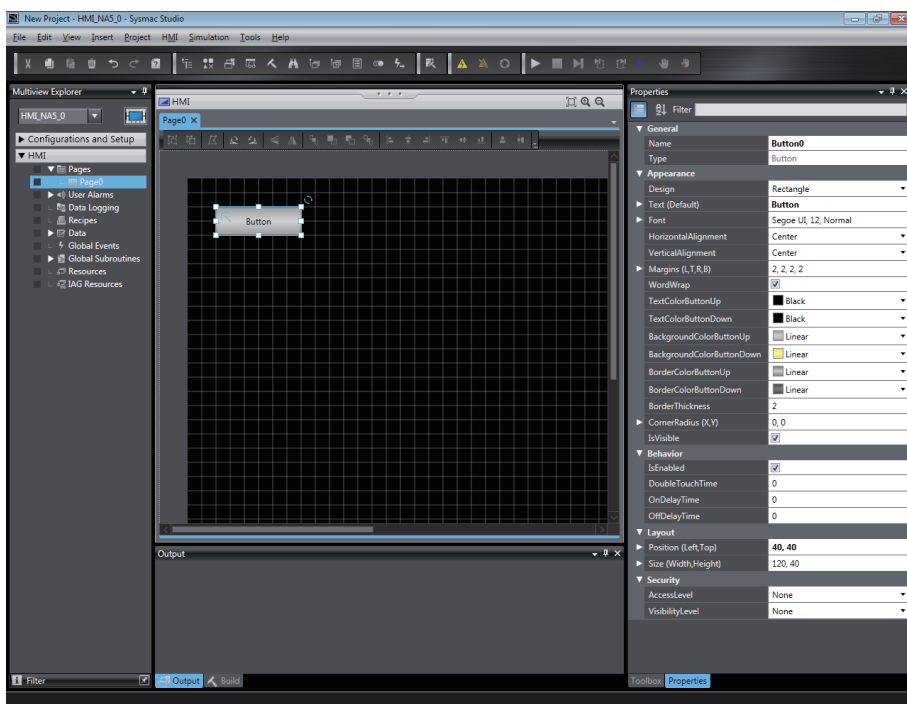

Make the following settings as required.

Setting Animations

- 1 Select **Animations** from the View Menu.

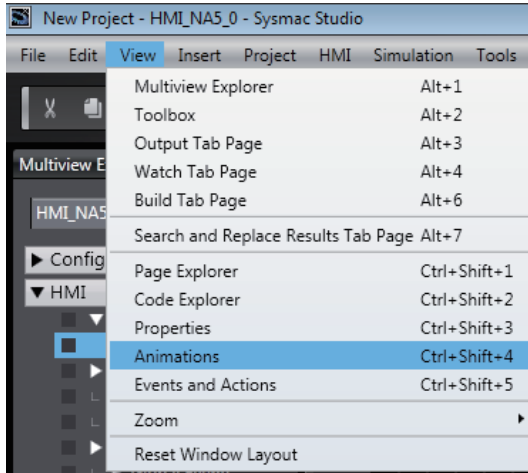

- 2 You can set the animations of the objects in the Animations Window.

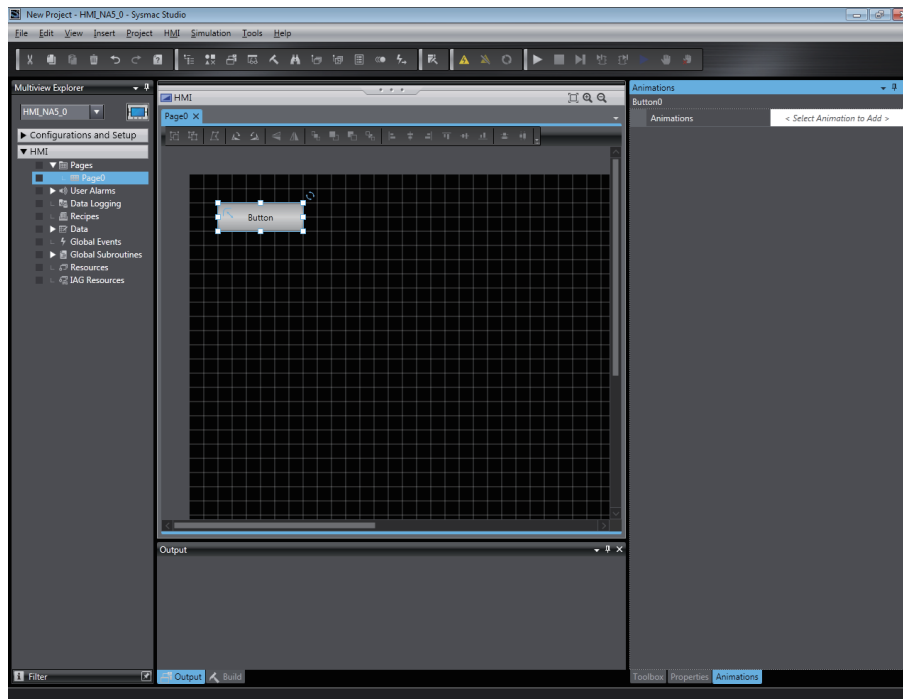

Setting Events and Actions

- 1 Select **Events and Actions** from the View Menu.

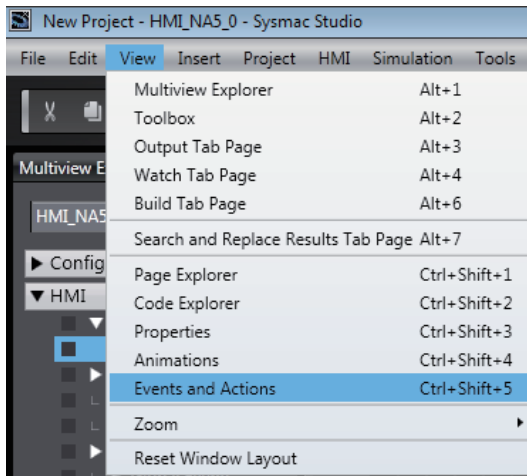

- 2 You can set the actions for events in the Events and Actions Window.

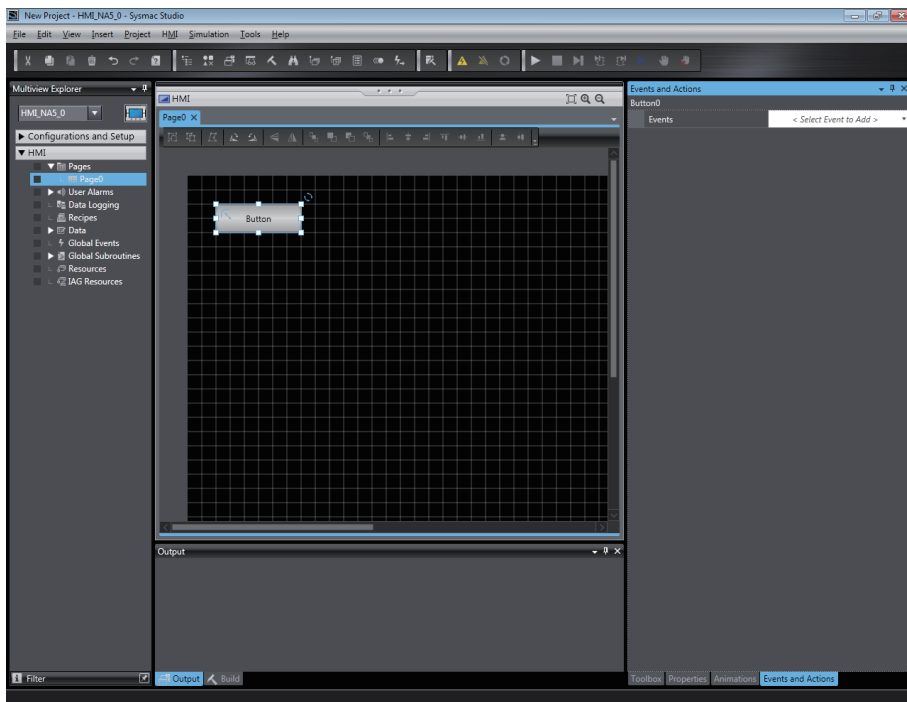

5-2 Examples of Using Objects

This section provides examples of using objects.

5-2-1 Displaying a PDF File

The following example shows how to display a PDF file full screen when a button is touched.

- 1 Place a button on the page.

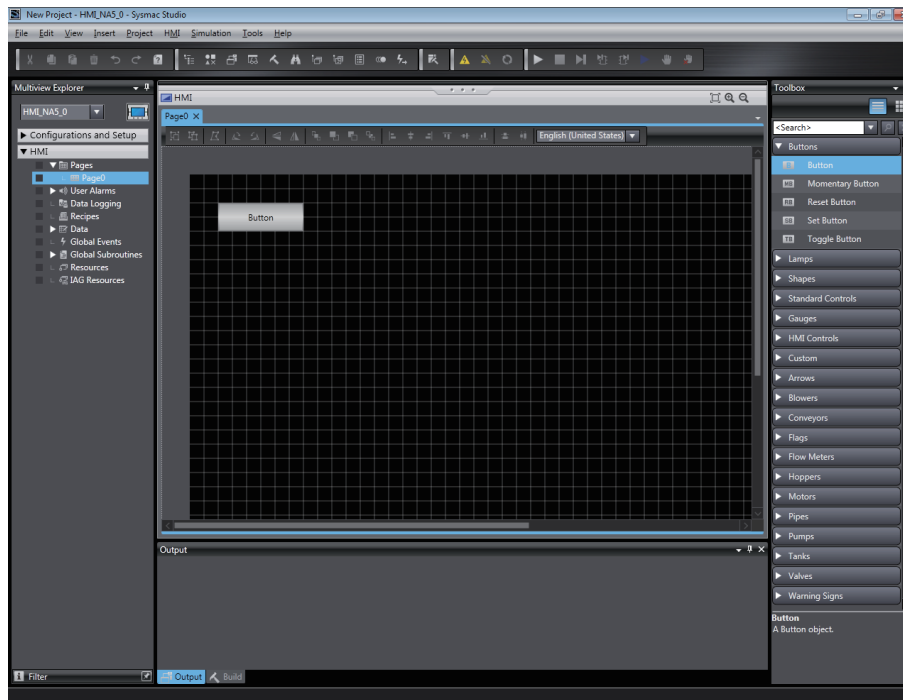

- 2 Select **Events and Actions** from the View Menu.

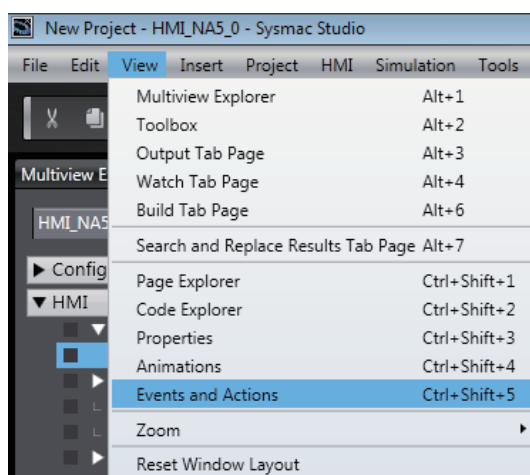

- 3 Select **Click** as the event.

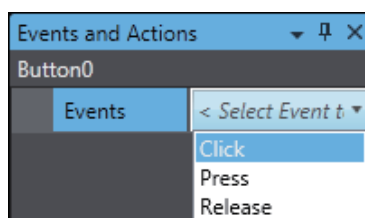

- 4 Select *ShowDocument(FullScreen)* as the action.

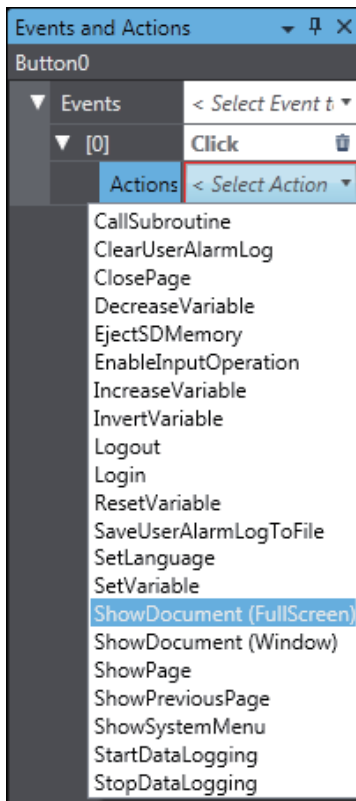

- 5 Set the name of the file to display.

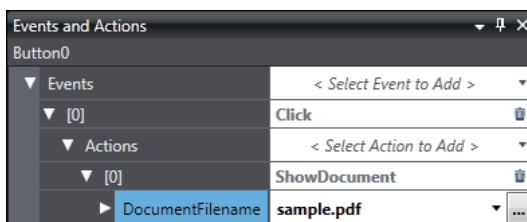

Transfer the project to the HMI and confirm the operation.

The PDF file should be displayed when the button is touched.

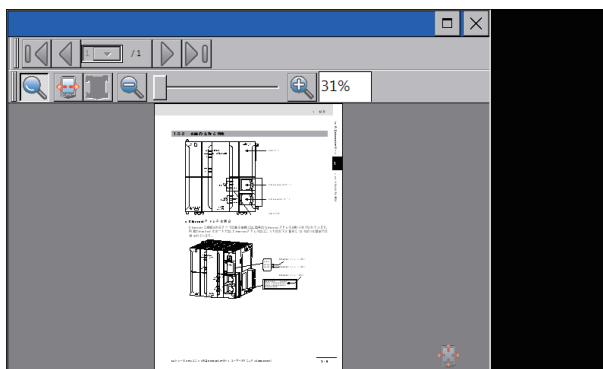

5-2-2 Displaying a User Alarm

The following example shows how to register a user alarm and display a message when the user alarm occurs.

This example creates a user alarm that displays the message *Alarm1* in a confirmation dialog box when the *blnAlarm1* variable changes to True.

- 1 Right-click **HMI** under **User Alarms** in the Multiview Explorer and select **Add - Group** from the menu.

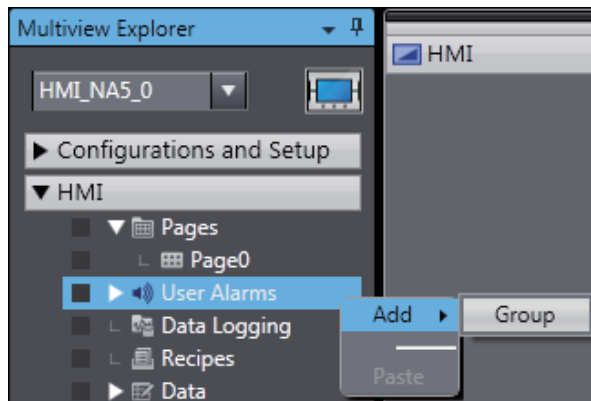

- 2 Double-click the new group.

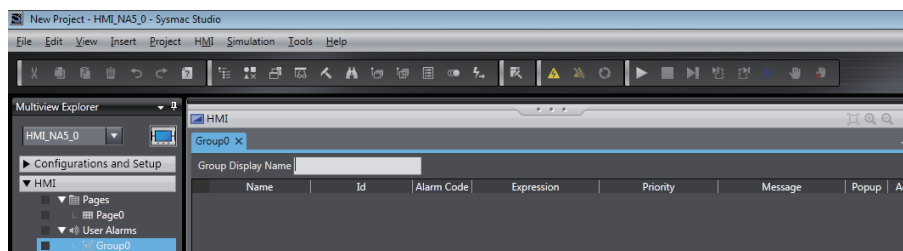

- 3 Right-click in the user alarm table for the new group and select **Add** from the menu.

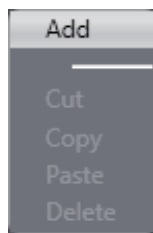

- 4 A row is added. Make the following settings in the new row. Use the default values for settings that are not specified.

Name: UserAlarm1

Expression: blnAlarm1=True

Message: Alarm1

Popup: Selected

Acknowledge: Selected

Name	Id	Alarm Code	Expression	Priority	Message	Popup	Acknowledge	Details
UserAlarm1	Group0_UserAlarm1		blnAlarm1=True	User Fault Level 4	Alarm	<input checked="" type="checkbox"/>	<input checked="" type="checkbox"/>	

- 5 Double-click **HMI - Pages - Page0** in the Multiview Explorer. Drag a User Alarms Viewer object from **HMI Controls** in the Toolbox to the page.

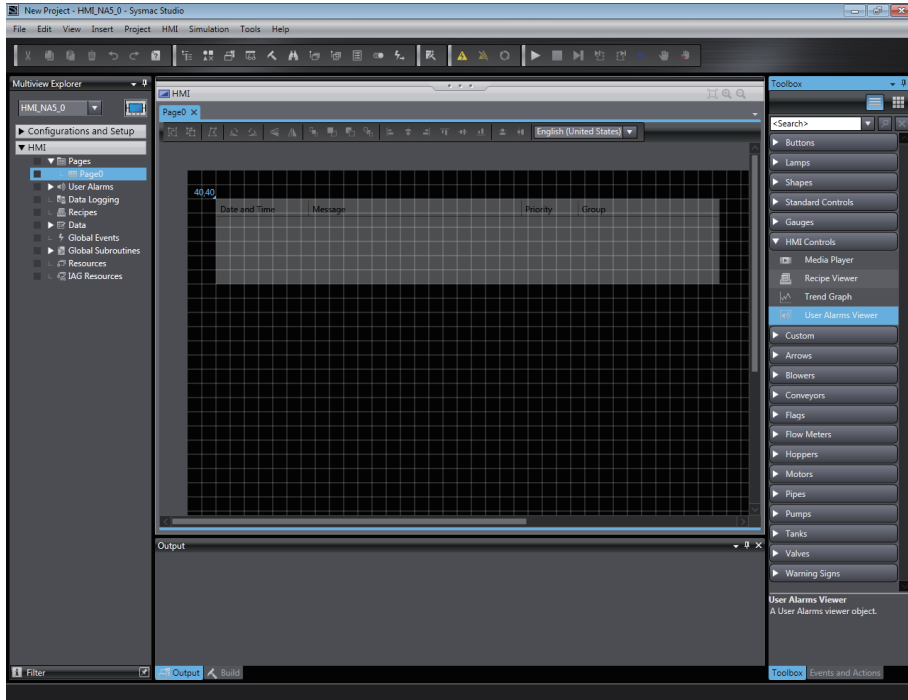

Transfer the project to the HMI and confirm the operation.

When the *blnAlarm1* variable changes to True, the contents that was set for the User Alarms Viewer object are displayed in a confirmation dialog box.

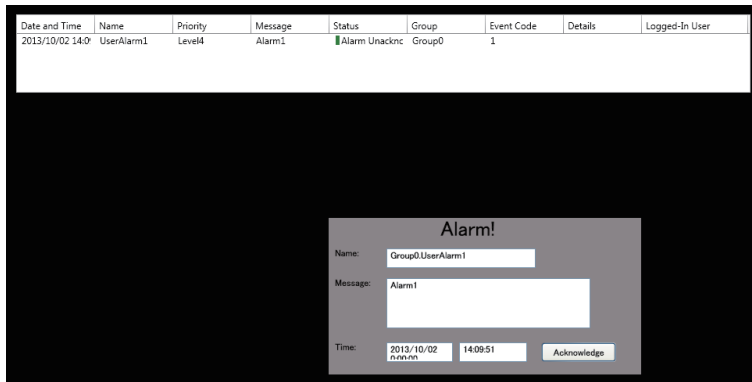

5-2-3 Displaying a Trend Graph

The following example shows how to register a data set for data logging and display a trend graph that accesses it.

This example records log data continuously every 5 seconds and saves it in a separate file for each 24-hour period.

- 1 Register an integer variable called *intDatalog1* in the global variable table.
- 2 Right-click **HMI - Data Logging** in the Multiview Explorer and select **Add - Data Set** from the menu.

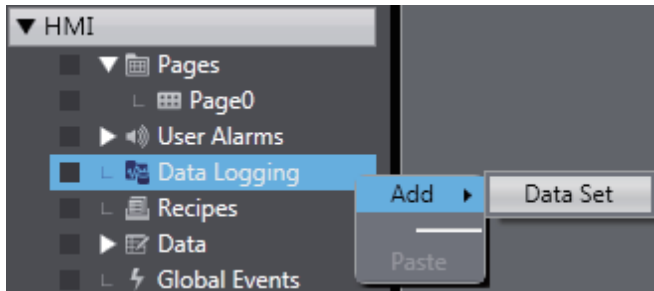

- 3 Double-click the new data set.

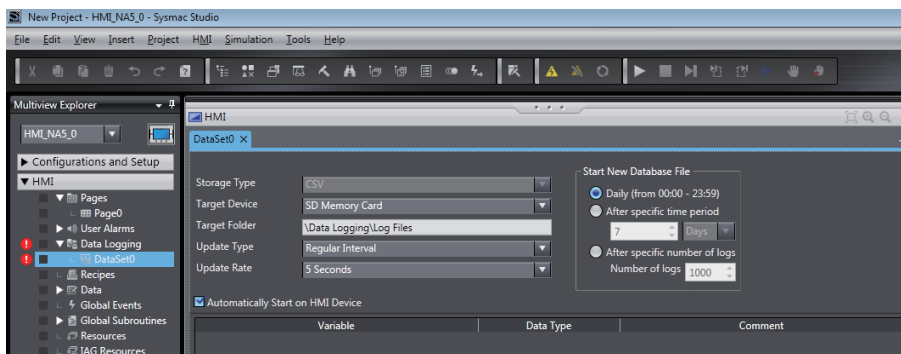

- 4 Right-click in the new data set grid and select **Add** from the menu.

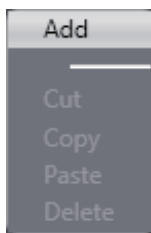

- 5 A row is added. Set *intDatalog1* in the *Variable* column of the new row. Use the default values for other settings.

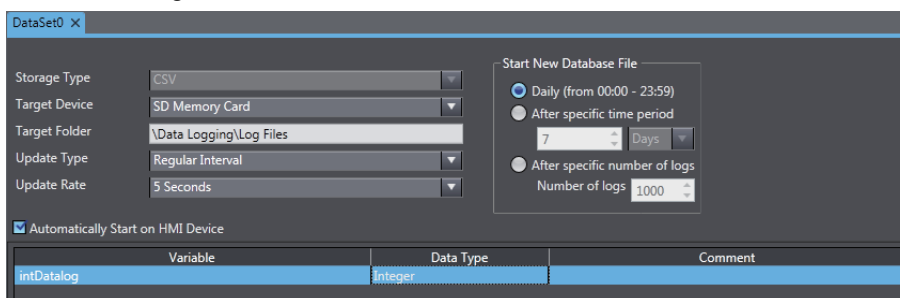

- 6 Double-click **HMI - Pages - Page0** in the Multiview Explorer. Drag a Trend Graph object from **HMI Controls** in the Toolbox to the page.

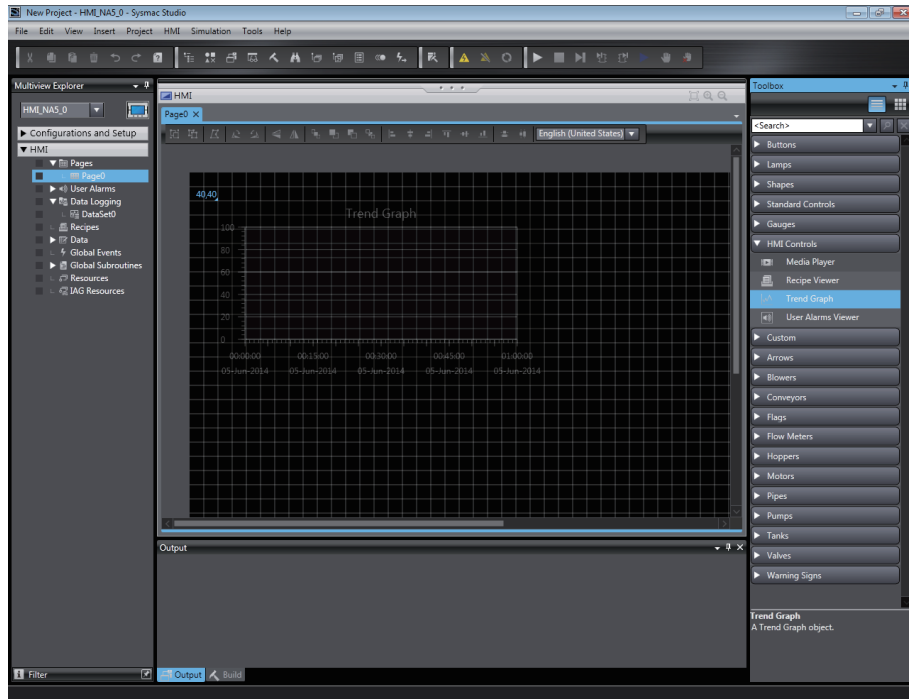

- 7 Set the name of the data set that you created as the data set in the properties.

Data	
DataSet	DataSet0
AnalogTraces	0 +
DigitalTraces	0 +

- 8 Click the ⊕ for *Analog Traces* and set the variable to display on the graph. Set *intDatalog1* as the variable.

Data	
DataSet	DataSet0
▼ AnalogTraces	1 +
▼ [0]	analogTrace0 : [0]
Name	analogTrace0
Variable	intDatalog
ScaleAss	Left Scale ▼
Color	DarkOrchid ▼
MarkerT	None ▼
DigitalTraces	0 +

Insert an SD Memory Card into the HMI, transfer the project to the HMI, and confirm the operation.

Every 5 seconds, the value of *intDatalog1* should be sampled and displayed on the graph.

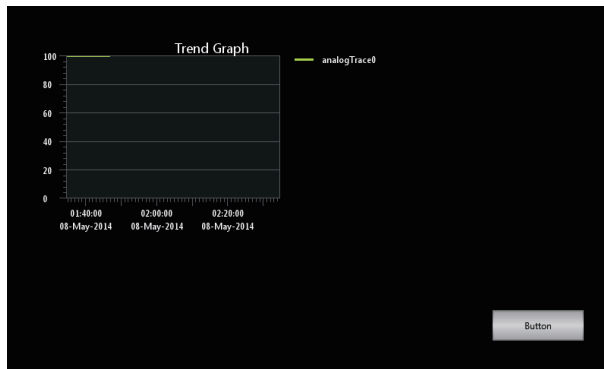

5-2-4 Using a Recipe

The following example shows how to use a recipe.

- 1 Register integer variables called *intRecipe1* and *intRecipe2* in the global variable table.
- 2 Right-click **HMI - Recipes** in the Multiview Explorer and select **Add - Recipe Template** from the menu.

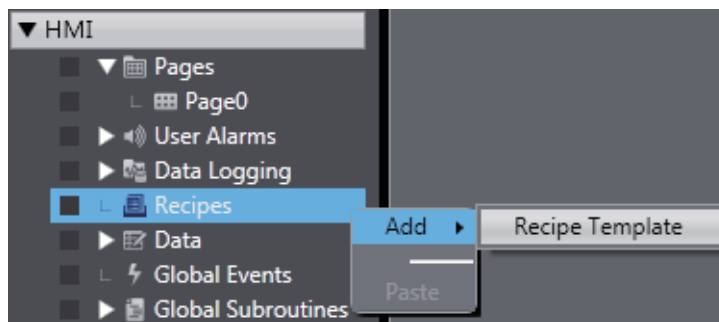

- 3 Double-click the new recipe template.

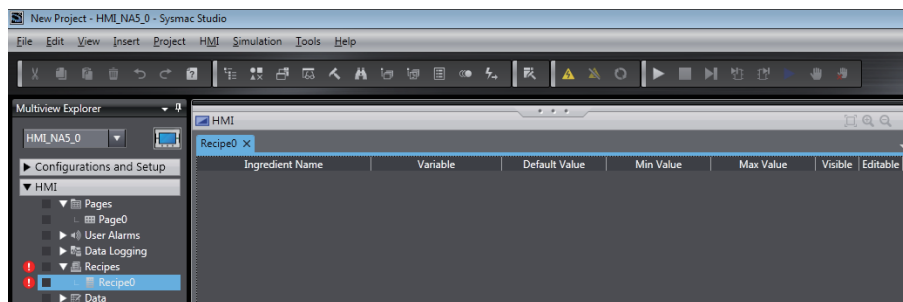

- 4 Register ingredients in the recipe template for the new recipe, Recipe0. Right-click in the grid and select **Add** from the menu.

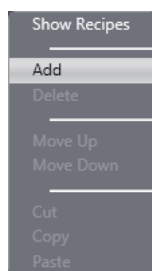



Additional Information

A recipe template is a defined data structure for a recipe.

- 5** A row is added. Make the following settings in the new row. Use the default values for other settings.

Ingredient Name: Recipe1

Variable: intRecipe1

Default Value: 10

Min Value: 0

Max Value: 100

Set Recipe2 as follows:

Ingredient Name: Recipe2

Variable: intRecipe2

Default Value: 20

Min Value: 0

Max Value: 100

Ingredient Name	Variable	Default Value	Min Value	Max Value	Visible	Editable
Recipe1	intRecipe1	10	0	100	<input checked="" type="checkbox"/>	<input checked="" type="checkbox"/>
Recipe2	intRecipe2	20	0	100	<input checked="" type="checkbox"/>	<input checked="" type="checkbox"/>

- 6** Right-click in the grid and select **Show Recipes** from the menu.

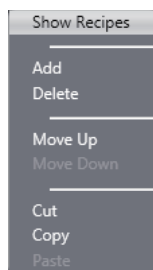

- 7** Right-click in the grid and select **Add** from the menu.

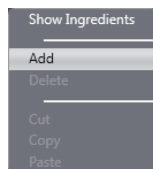

Additional Information

Recipes make settings in advance that are actually set according to the data structure.

- 8 A row is added. Make the following settings in the new row. Use the default values for other settings.

Recipe Name: RecipeSample1

Recipe1: 30

Recipe2: 40

Recipe Name: RecipeSample2

Recipe1: 50

Recipe2: 60

Recipe Name	Recipe1	Recipe2
RecipeSample1	30	40
RecipeSample2	50	60

- 9 Create a button to transfer the recipe.

Right-click **HMI - Pages - Page0** in the Multiview Explorer and select **View Code** from the menu.

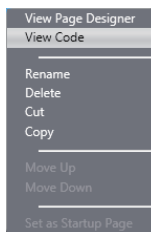

- 10 Create the following subroutine.

```

Page0.vb X
1 'Code behind Page - Add local subroutines for the page.
2 Sub WriteSubroutine
3   WriteRecipeToController("Recipe0","RecipeSample1")
4 End Sub
5

```

- 11 Double-click **HMI - Pages - Page0** in the Multiview Explorer. Drag a Recipe Viewer object from **HMI Controls** in the Toolbox to the page.

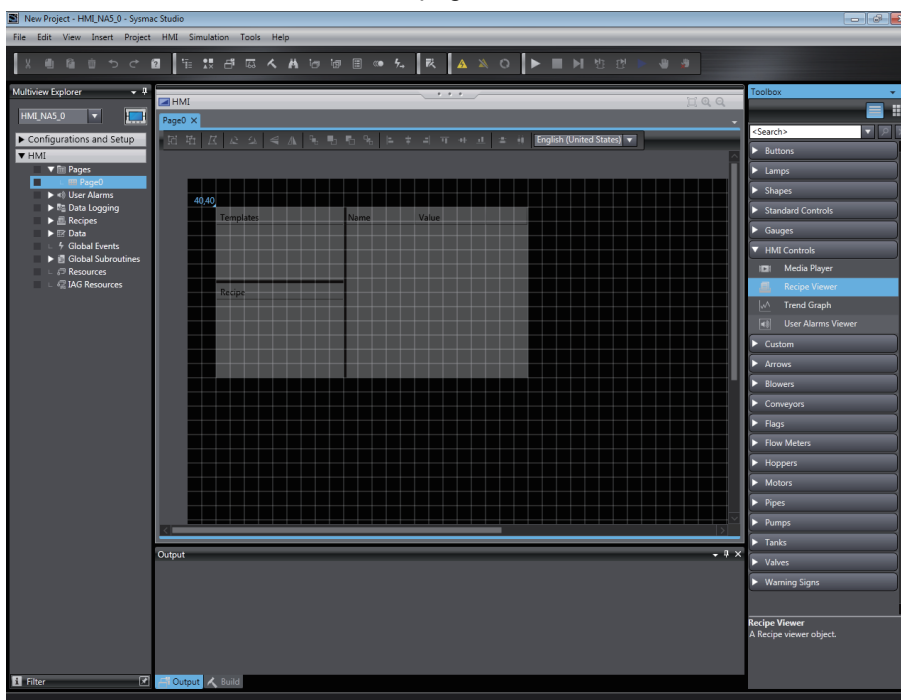

- 12** Then drag a Button object from **Buttons** in the Toolbox to the page and set the following event and action.

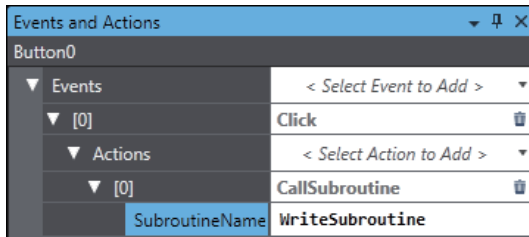

Transfer the project to the HMI and confirm the operation.

When the button is touched, the values that are set for the specified recipe should be written to the connected device.

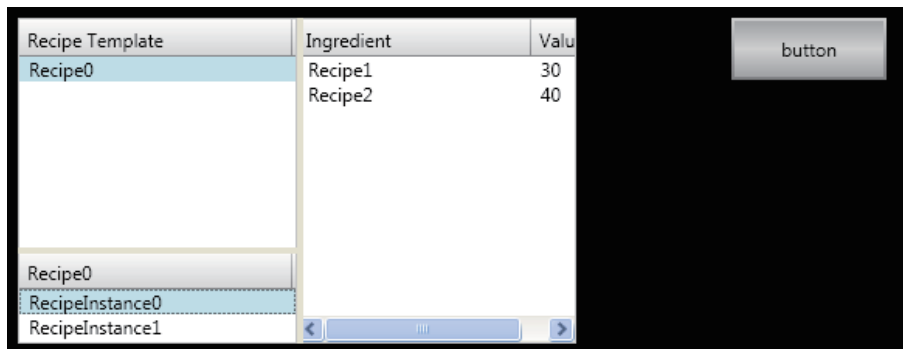



Connecting to the HMI

This section describes how to go online with an HMI.

6-1	Introduction	6-2
6-2	Going Online with an HMI	6-3
6-2-1	Methods for Going Online with an HMI	6-3
6-2-2	Setting the Connection Method	6-4
6-2-3	Online Connection	6-5
6-2-4	Going Online after Checking the Connection Method	6-6
6-2-5	Going Offline	6-6
6-2-6	Confirming Serial IDs	6-6

6-1 Introduction

Connecting to the HMI

You must go online with the HMI or connect to the Simulator to communicate with it from the Sysmac Studio.

The Sysmac Studio supports the following online connections for different applications.

Online connection	Connection made to	Application
Online connection	The actual HMI	To perform debugging, startup, or normal maintenance, the same project as in the actual HMI is opened on the Sysmac Studio and then an online connection is made. An online connection is made based on the Communications Setup in the project.
Simulator connection	HMI Simulator	The Simulator is used to debug the program offline. The Communications Setup in the project is not used.



Additional Information

Refer to *7-1-4 Offline Debugging with Only the HMI Simulator* on page 7-6 for information on connecting to the Simulator and debugging operations.

6-2 Going Online with an HMI

You can simultaneously go online with more than one HMI in a project from the Sysmac Studio. The operations that are described in this section apply to the currently selected HMI. If there is more than one HMI registered in the project, confirm the HMI to operate before connecting to it.





Precautions for Correct Use

Do not reconnect the USB cable for at least 10 seconds after you disconnect it. After you connect the USB cable, do not disconnect it until Windows detects the connection.

It may become impossible for Windows to detect when the cable is connected or disconnected, which would effectively disable the USB port. If that occurs, restart the computer. Otherwise, you will not be able to use the USB device until Windows recovers from the suspended status.

6-2-1 Methods for Going Online with an HMI

To go online with an HMI, there are three connection methods that can be used. These are described in the following table.

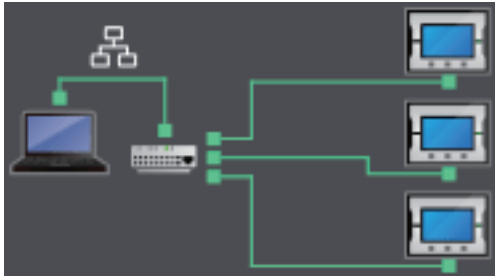
Connection method	Connection diagram	Description
Direct connection via USB		The USB port on the computer is connected directly to the USB slave port on the HMI. This is the default connection configuration.
Direct connection via Ethernet		The Ethernet port on the computer is connected directly to Ethernet port 2 on the HMI.
Ethernet connection via hub		The Ethernet port on the computer is connected through the Ethernet network to an Ethernet port on the HMI.

6-2-2 Setting the Connection Method

You must set the connection method, IP address to connect to, and other parameters for communications between the computer and HMI.

- 1 Select **Communications Setup** from the HMI Menu.
The Communications Setup Dialog Box is displayed.

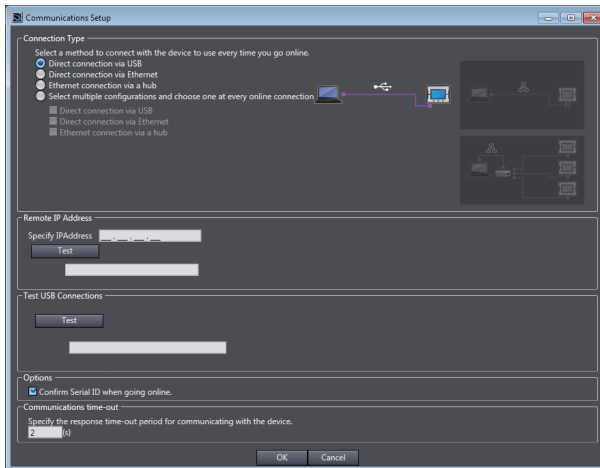

- 2 Select the connection method for the connection configuration in the *Connection Type* Field.
For an Ethernet connection via a hub, enter the IP address of the HMI to which you need to connect in the Remote IP Address Area. Select any required options and enter the communications time-out time if required.

Note Refer to *Communications Setup Dialog Box Settings* on page 6-5 on the next page for information on the settings.

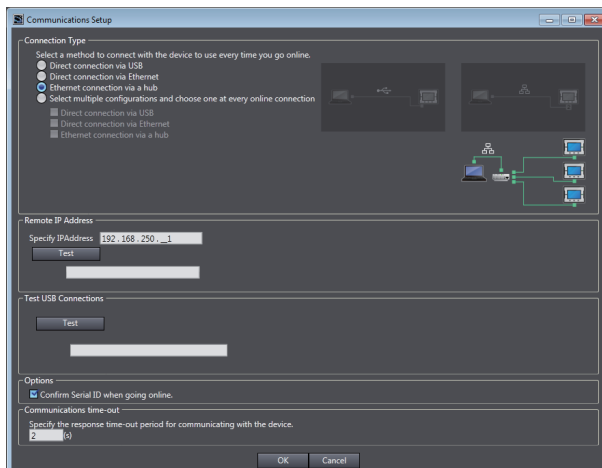

- 3 Click the **OK** Button.
This concludes the settings.

● Communications Setup Dialog Box Settings

Item	Description	
Connection Type	Select the connection port to use to go online. The selected method is normally used to go online.	
Remote IP Address	If you specify an Ethernet hub connection, set the IP address of the HMI that you will connect to. Also, you can click a test button to perform a communications test.	
Test USB Connections	Click the test button to perform a USB communications test.	
Options	Confirm serial ID when going online.	If you select this option, the names and serial IDs are compared between the project and the HMI when you go online to make sure that a connection is made to the intended HMI.
Communications time-out	You can set the response monitoring time for communications with the HMI. An error is displayed if a response is not received before this time expires. *1. The time can be set to between 1 and 3,600 s.	

6-2-3 Online Connection

Use the following procedure to place the Sysmac Studio online with the HMI.

- 1 Select **Online** from the HMI Menu. Or, click the **Go Online** Button  in the toolbar.

The following message is displayed the first time you go online. After you write the project name, this message is not displayed.

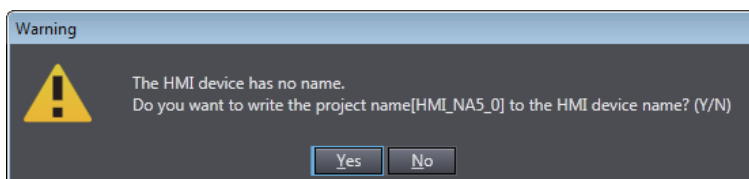

Additional Information

The same message will be displayed the next time you connect if the HMI device name that is set in the project is different from the HMI device name that is set in the HMI.

- 2 Click the **Yes** Button.

The Sysmac Studio goes online and the color of the bar at the top of the Edit Pane changes to yellow.

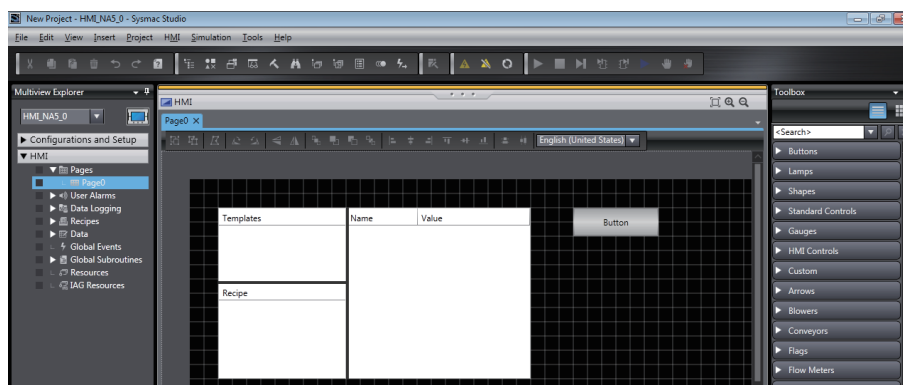

6-2-4 Going Online after Checking the Connection Method

Use the following procedure to go online if you selected the option to select the connection method whenever you connect the computer with the HMI in the Communications Setup Dialog Box.

- 1 Select **Online** from the HMI Menu. Or, click the **Go Online** Button (⚠) in the toolbar.
The Communications Setup Dialog Box is displayed.

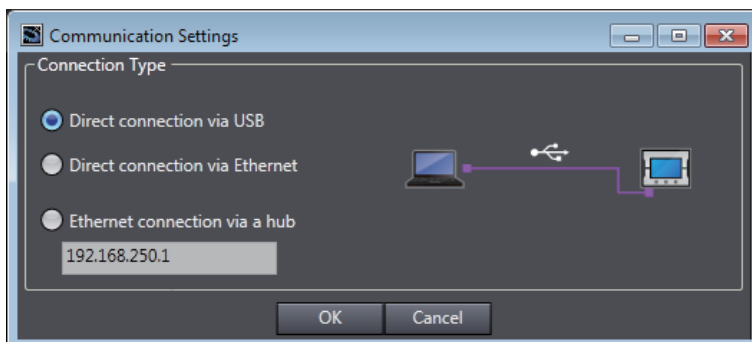

The IP address that is set in the Communications Setup Dialog Box is displayed below the *Ethernet connection via a hub* Option.

- 2 Select the connection method and then click the **OK** Button.
The Sysmac Studio goes online.

6-2-5 Going Offline

Use the following procedure to go offline.

- 1 Select **Offline** from the HMI Menu. Or, click the **Go Offline** Button (⚠) in the toolbar.
The Sysmac Studio goes offline.

6-2-6 Confirming Serial IDs

The serial ID is verified when going online if the option to do so was selected in the Communications Setup Dialog Box. If the serial ID of the project on the Sysmac Studio is different from that of the HMI, the following confirmation dialog box is displayed when you attempt to go online.

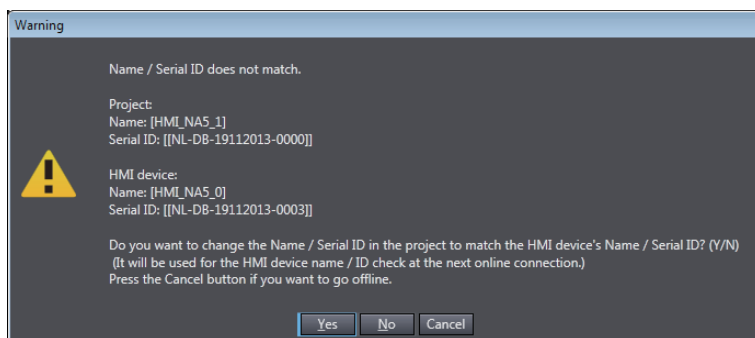

- 1 Click the **Yes** Button.
The serial ID of the project on the Sysmac Studio is rewritten to the same value as that of the HMI.



Precautions for Correct Use

- If a USB connection is used, an Ethernet IP address of 192.168.255.xxx is used internally. When using a USB connection, do not use an IP address of 192.168.255.xxx for the Ethernet interface card in the computer.
 - Socket ports 9600 and 2224 are used for Ethernet UDP/IP communications. When using Ethernet UDP/IP communications, do not use these ports for any other application.
 - When using a direct Ethernet connection and there is more than one Ethernet interface card mounted in the computer, you must select the Ethernet interface card to use. Refer to the *Sysmac Studio Version 1 Operation Manual* (Cat. No. W504) for specific selection procedures.
-



Debugging

This section describes offline debugging using the HMI Simulator.

7-1 HMI Debugging Functions	7-2
7-1-1 Watch Tab Page	7-2
7-1-2 Breakpoints	7-3
7-1-3 Step Execution	7-4
7-1-4 Offline Debugging with Only the HMI Simulator	7-6
7-1-5 Offline Debugging with the Controller Simulator	7-7

7-1 HMI Debugging Functions

The operations you can use for debugging on the Sysmac Studio are listed below. The HMI Simulator is used for offline debugging. You can use the HMI Simulator by itself, or you can connect it to the Controller Simulator to debug the entire system.

Caution

Although the Simulator simulates the operation of the HMI, there are differences from the HMI in operation and timing. After you debug operation with the Simulator, always check operation on the actual Controller and HMI before you use them in the actual system. Accidents may occur if the controlled system performs unexpected operation. Refer to *A-3 Differences between the Physical HMI and Simulator* on page A-5 for details on differences in operation.



Although offline debugging simulates the integrated operation of the HMI and Controller, there are differences in operation and timing in comparison with combining the actual HMI and Controller. After you debug operation with the simulation, always check operation on the actual Controller and HMI before you use them in the actual system. Accidents may occur if the controlled system performs unexpected operation. Refer to *A-3 Differences between the Physical HMI and Simulator* on page A-5 for details on differences in operation.



The following three functions are provided for debugging during HMI simulations. These functions are the same regardless of whether they are used in offline debugging.

- Watch Tab Page
- Breakpoints
- Step execution

7-1-1 Watch Tab Page

The basic Sysmac Studio operations of the Watch Tab Page apply to HMIs.

Refer to the *Sysmac Studio Version 1 Operation Manual* (Cat. No. W504) for details.

However, the following differences exist for HMI projects.

- You can monitor the following variables on the Watch (Project) Tab Page.

Standard projects:	Only global variables can be registered. You can continuously monitor any of the global variables. Register the variable names as they are.
IAG projects:	You can register only user-defined variables. You can monitor only the user-defined variable in the IAG when execution is paused for a breakpoint. Register variable names in the following format: <code>Me.Variable_name</code> .
- The Watch Tab Page functions only for the Simulator. Even if you are online with the physical HMI, you cannot monitor the variables in the physical HMI.
- You can monitor values in the Watch Tab Page only when the project is paused at a breakpoint. Values are not displayed under any other conditions.
- A red box is displayed for variables registered in the Watch Tab Page if the values cannot be obtained, such as when not pausing at a breakpoint.

7-1-2 Breakpoints

You can set breakpoints in the source code of a subroutine. You can use breakpoints to pause the execution of a subroutine at any desired point.

Setting and Clearing Breakpoints

● Setting Breakpoints

You can set breakpoints to pause execution of a simulation, e.g., to see the status after a subroutine is executed.

● Procedure

To set a breakpoint, move the cursor to the line in the subroutine where you want to set the breakpoint and select **Set/Clear Breakpoint** from the Simulation Menu.

If you repeat this operation, the breakpoint will be cleared.

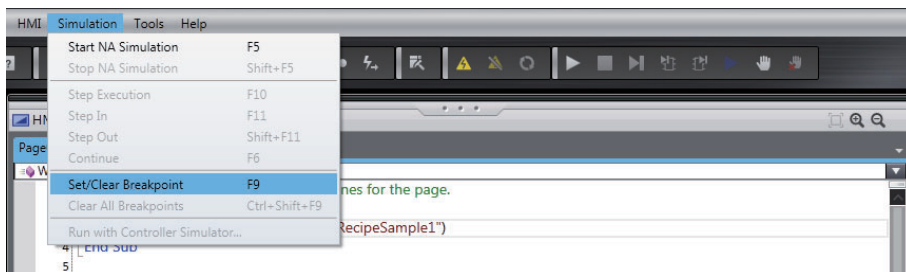

Clearing All Breakpoints

You can clear all of the breakpoints at the same time.

Select **Clear All Breakpoints** from the Simulation Menu to clear all of the breakpoints.

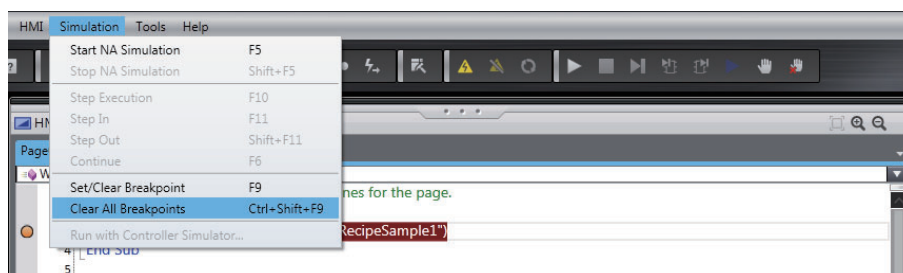

7-1-3 Step Execution

You can use step execution when subroutine execution is paused at a breakpoint to trace operation one line of the source code at a time.

Step Execution

You can use step execution to execute the source code of a subroutine one line at a time.

If you select **Step In** and other commands from the Simulation Menu while paused at a breakpoint during a simulation, you can control execution one line or one function at a time.

Step Execution

The **Step Execution** command executes one function at a time.

Select **Step Execution** from the Simulation Menu when subroutine execution is paused during step-in execution.

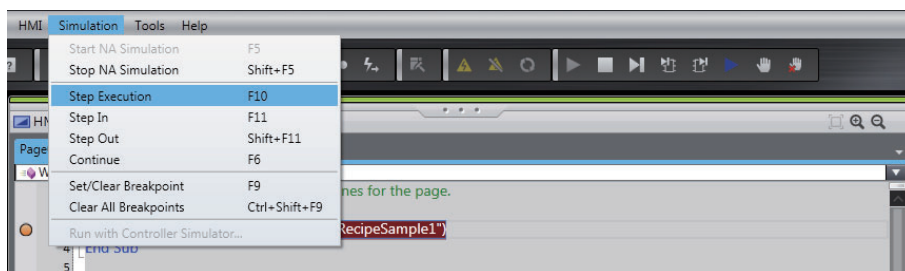

Step-in Execution

Step-in execution performs step execution for the source code of a subroutine.

When you execute a program through the Simulator, select **Simulation - Step In** when the subroutine is stopped at a breakpoint, paused, or stopped during step execution.

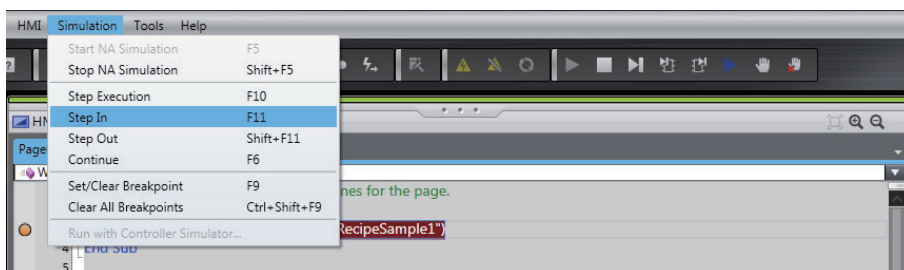

Step-out Execution

Use the **Step Out** command to exit a subroutine during step-in execution.

Select **Step Out** from the Simulation Menu during step-in execution.

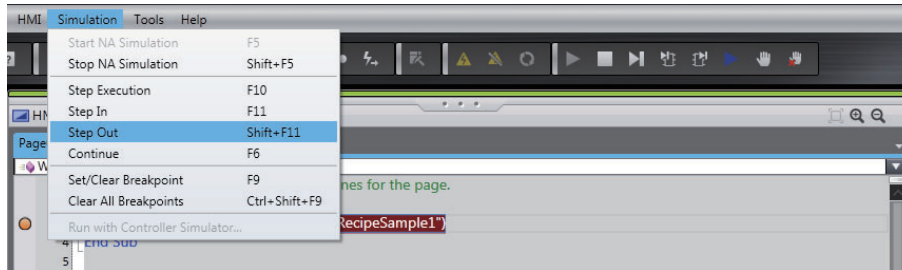

Continue

The **Continue** command executes the subroutine to the next breakpoint.

Select **Continue** from the Simulation Menu when subroutine execution is paused during step-in execution.

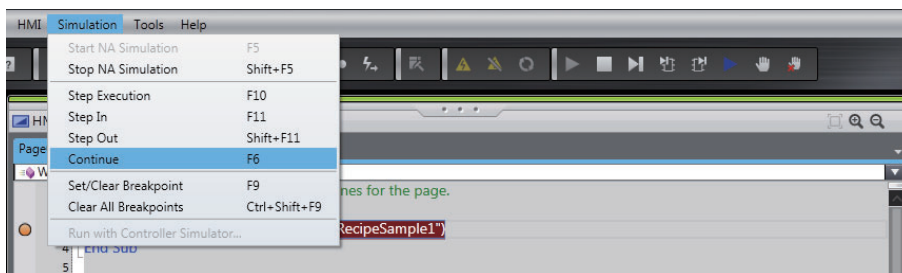

7-1-4 Offline Debugging with Only the HMI Simulator

Before you check the entire system, you can perform debugging with the HMI Simulator alone.

When you create a project and want to debug it, always check operation with only the HMI Simulator first. The Sysmac Studio comes with a Simulator that simulates HMI functions.

Procedure

Use the following procedure to start the Sysmac Studio and perform debugging.

- 1 Start the Sysmac Studio and create a project.
- 2 Create the HMI application.
- 3 Select **Build HMI** from the Project Menu to build the project.
- 4 Select **Start NA Simulation** from the Simulation Menu.

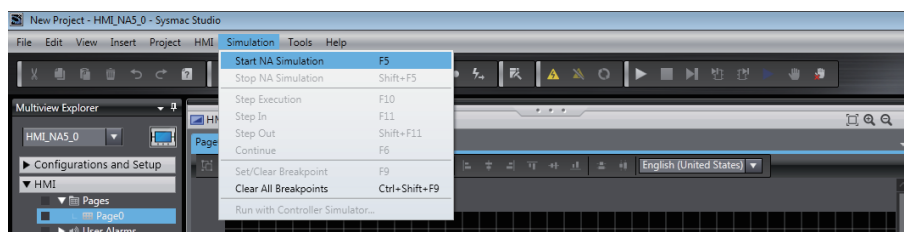

The Simulator starts.

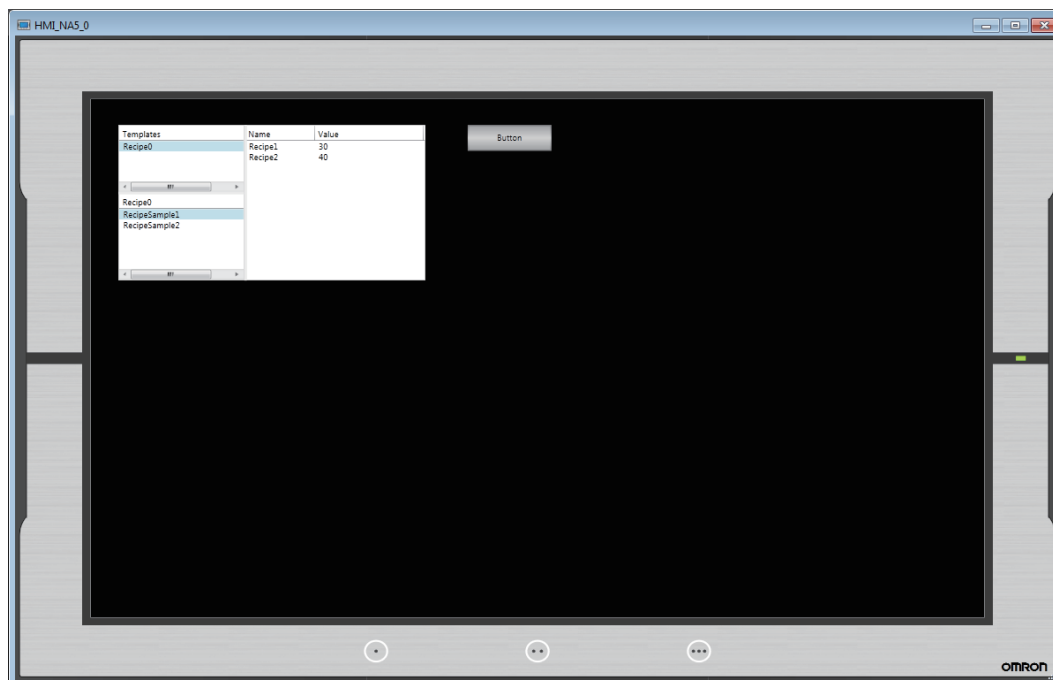

Additional Information

If the project is not yet built, it is built automatically.

- 5** To stop the simulation, click **Stop NA Simulation** from the Simulation Menu. The HMI Simulator is ended.

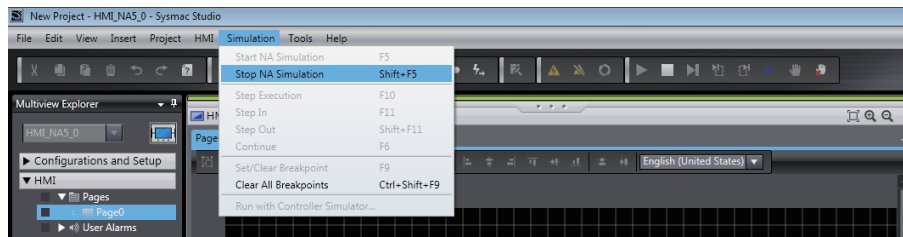

7-1-5 Offline Debugging with the Controller Simulator

You can perform debugging with the HMI Simulator connected online to the Controller Simulator. This allows you to debug the project while the Controller program is actually running.

After you complete checking operation with the HMI Simulator alone, check operation that includes the Controller program. The Sysmac Studio enables integrated debugging of the Controller program and the HMI application by connecting the Controller Simulator to the HMI Simulator.

You can perform debugging with the HMI Simulator and Controller Simulator connected when either the HMI or the Controller is selected, but the restrictions depend on which is selected, as described below. You cannot change a device while debugging is in progress.

- **Starting When the HMI Is Selected**
You cannot use the debugging functions and Simulator control functions of the Controller. The only Controller debugging function you can use is monitoring in the Watch Tab Page.
- **Starting When the Controller Is Selected**
You cannot use the debugging functions of the HMI. The only HMI debugging function you can use is monitoring in the Watch Tab Page.

Procedure

Synchronization is used to transfer the project from the Sysmac Studio to the HMI.

- 1 Start the Sysmac Studio and create a project.
- 2 Create the Controller program.
- 3 Create the HMI application.
- 4 Select **Build HMI** from the Project Menu to build the project.
- 5 Select **Run with Controller Simulator** from the Simulation Menu.

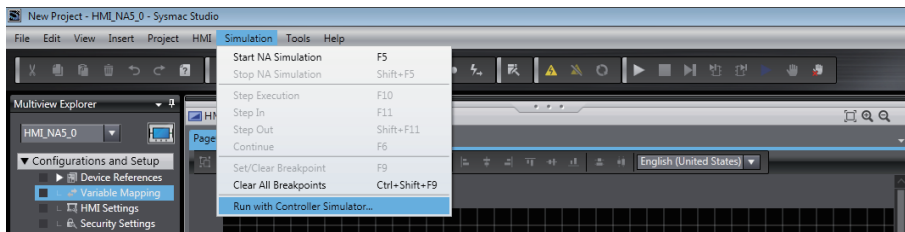

Additional Information

If there is more than one Controller in the project, the window will be displayed for the Controller that is currently connected. If you select a Controller for which variables are not mapped, an error will occur and starting the Simulator will be canceled.

The Controller Simulator is started and the HMI Simulator is displayed.

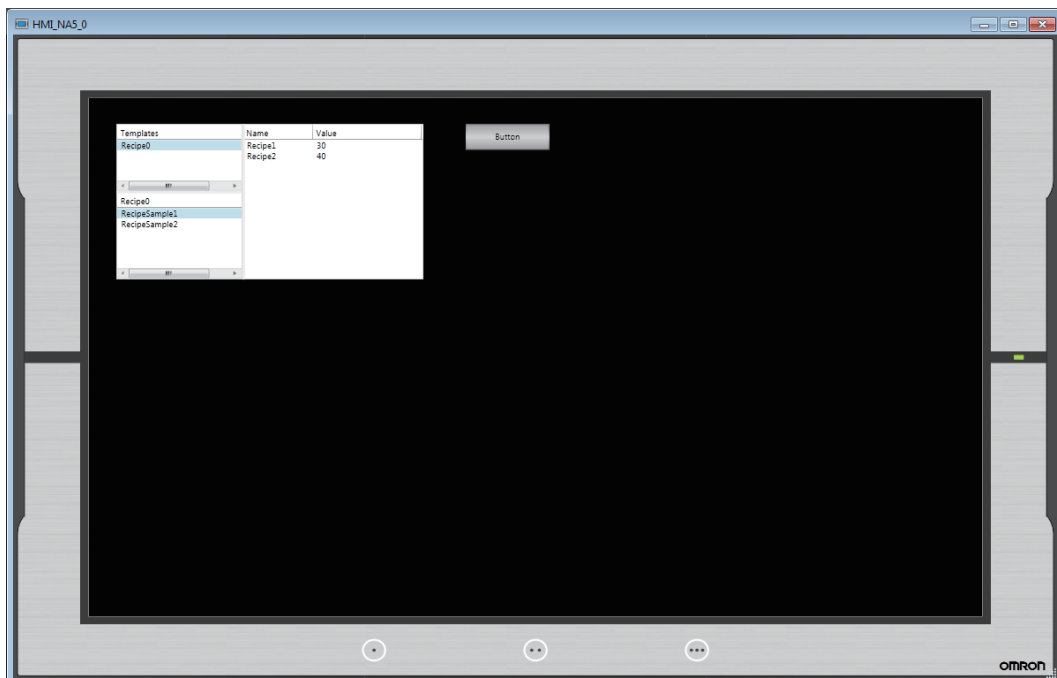

Additional Information

If the project is not yet built, the entire project including the Controller is built automatically. If a building error occurs for the Controller, a dialog box is displayed to notify you of the error. Change the device to the relevant Controller, build the project, and check the error.

- 6** To stop the simulation, click **Stop NA Simulation** from the Simulation Menu. The Controller Simulator and the HMI Simulator are stopped.

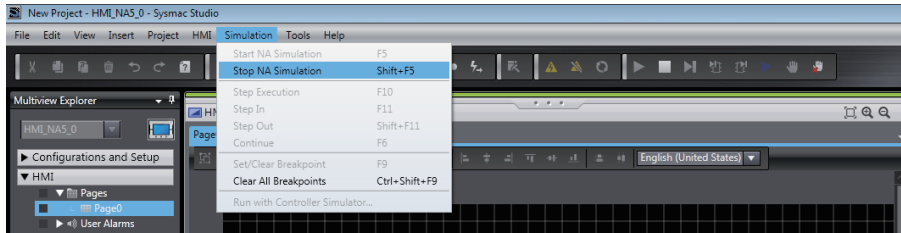

Additional Information

You can also start online debugging when the Controller is selected in the project. Refer to the *Sysmac Studio Version 1 Operation Manual* (Cat. No. W504) for details.



Synchronizing Projects

This section describes how to synchronize the projects between the HMI and the Sysmac Studio.

8-1 Synchronizing Projects	8-2
8-2 Using Storage Media for Synchronization	8-5

8-1 Synchronizing Projects

Synchronization is used to transfer the project from the Sysmac Studio to the HMI.

The basic Sysmac Studio operations for synchronization generally apply to HMIs. Refer to the *Sysmac Studio Version 1 Operation Manual* (Cat. No. W504) for details.

This section describes differences in synchronization when an HMI is selected.

WARNING

Sufficiently check the operation of any project that you create before you start actual system operation.



Precautions for Safe Use

Unexpected operation may result if you set inappropriate network configuration settings. Even if appropriate network configuration settings are set, confirm that the controlled system will not be adversely affected before you transfer the data.



Precautions for Correct Use

Do not perform any other operations on the Sysmac Studio while the Synchronization Window is active. An error will occur and synchronization will fail.

Functional Differences When an HMI Is Selected

The following differences exist in synchronization when an HMI is selected.

- Detailed comparison is not supported.
- Algorithm checking is not supported. Therefore, there is no way to prevent mismatches in build dates that result from rebuilding.
- Uploading is not supported.
- You can download only executable files, i.e., only built files.
Therefore, you cannot recover a project from the data in the HMI. Always manage projects on the computer.
- You must download the entire project to the HMI at the same time. You cannot download smaller units of project data.
- If the project version specified in the project is newer than the version of the project in the HMI, the runtime files will always be transferred.
- You can transfer the system program. The system program is automatically transferred when other data is downloaded if updating the system program is necessary.
- The following synchronization options are provided.

Option	Default	When transfer is enabled	Description
Clear the present values of variables with Retain attribute.	Selected.	Values written to HMI	If this check box is selected, the present values of Retain variables are cleared after the data is downloaded.
Clear alarm log data from memory	Selected.	Values written to HMI	If this check box is selected, the alarm log in non-volatile memory is cleared. If you have changed the user alarm settings, you cannot clear the selection of this check box.
Clear Data log data from memory	Selected.	Values written to HMI	If this check box is selected, the data log data in non-volatile memory is cleared. If you have changed the data logging settings, you cannot clear the selection of this check box.

Differences in Comparison Results

The following differences apply to the comparison results.

● Verification Results Example

The verification results are displayed as shown in the following example.

Column	Item
Source	Project name on the Sysmac Studio
Source Modified Date	The last time that the project was built on the Sysmac Studio
Target Modified Date	The last time that the HMI project was built on the Sysmac Studio
Target	HMI project name
Detailed Comparison	This column is not used when an HMI is selected.

● Verification Units

The units for comparison that are shown in the Synchronization Window are listed in the following table.

Synchronization data name	Level	Qty	Detailed comparison	Remarks
HMI name	1	1	None	
Project	2	1	None	
Pages	3	1	None	
Page*	4	N	None	
Subroutines	3	1	None	
SubroutineGroup*	4	N	None	
Variables	3	1	None	
Global Events	3	1	None	
Alarms	3	1	None	
Data logging	3	1	None	
Recipe Template	3	1	None	
Data	3	1	None	
User Accounts	4	1	None	
Recipe Instances	4	N	None	
Settings	3	1	None	
HMI Settings	4	1	None	
Security Settings	4	1	None	
Resources	3	1	None	
Runtime Files	3	1	None	

8-2 Using Storage Media for Synchronization

With an HMI, you can perform product synchronization with storage media.

- 1 Insert an SD Memory Card or USB memory device into the computer.
- 2 Select **Transfer to Media Device** from the HMI Menu.

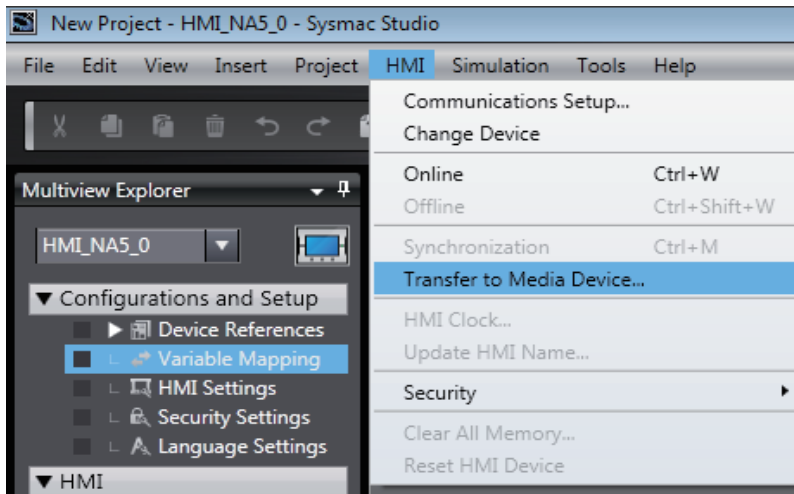

- 3 Select the folder to use for synchronization and click the **OK** Button.

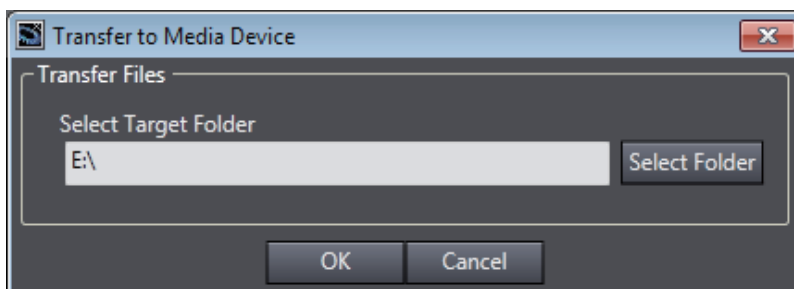

- 4 The project on the Sysmac Studio is compared with the project in the storage media and the Synchronization Window is displayed.

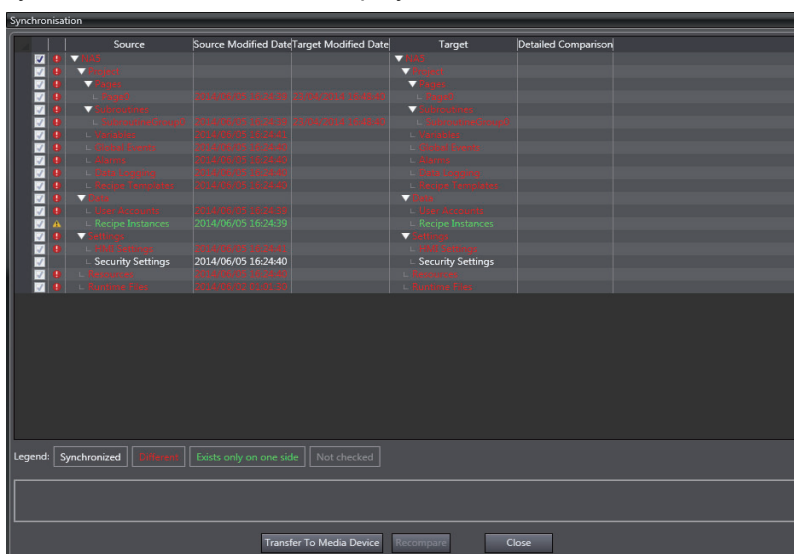

- 5 Click the **Transfer to Device** Button to transfer the project to the storage media.
- 6 Insert the storage media into the HMI, display the Device System Menu, and touch the **Transfer Operations** Button.

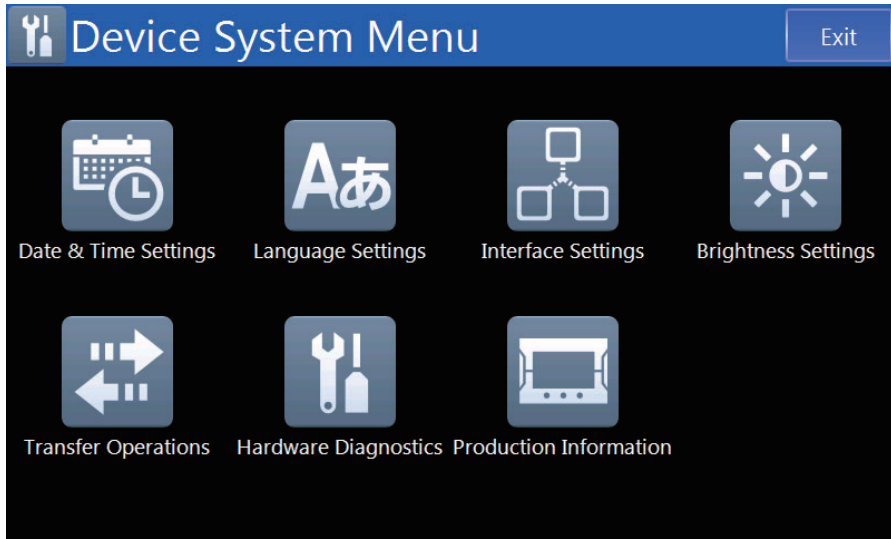

- 7 Touch the **Transfer User Program to HMI** Button.

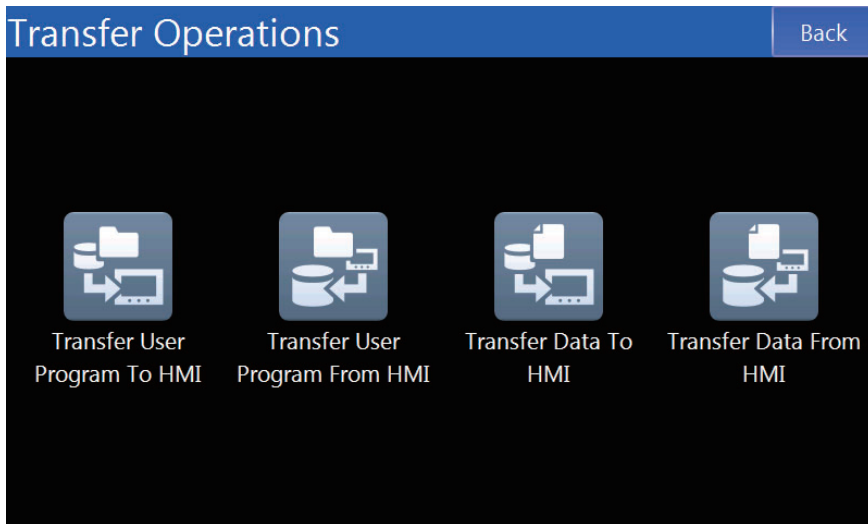

- 8 Select the project to transfer and touch the **Transfer to HMI** Button to download the selected project to the HMI.

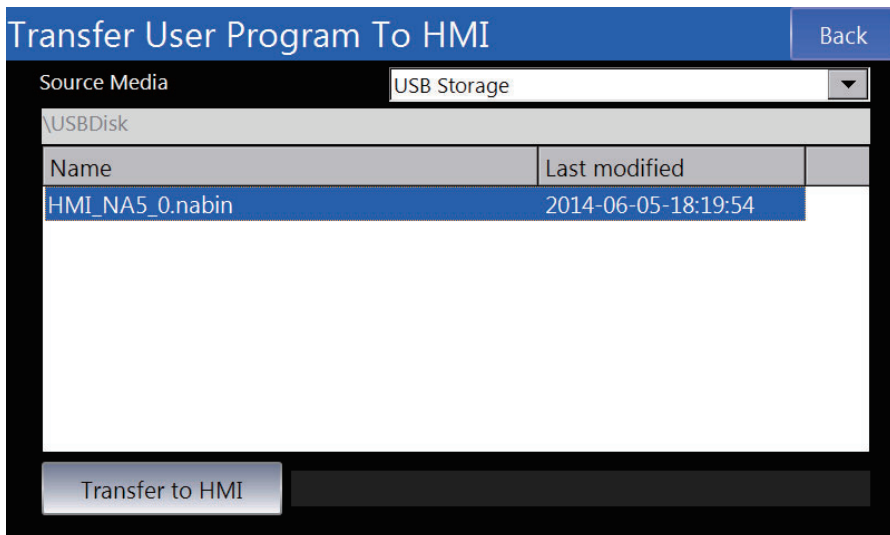

9

Reusing Objects

This section describes how to reuse objects.

9-1 Reusing Objects	9-2
9-2 IAGs	9-3
9-2-1 Differences when an IAG Project Is Selected	9-3
9-2-2 Creating an IAG	9-6
9-2-3 Using IAGs	9-9
9-3 Custom Objects	9-11
9-3-1 Objects That You Can Register as Custom Objects	9-11
9-3-2 Creating Custom Objects	9-11
9-3-3 Deleting Custom Objects	9-14
9-3-4 Using Custom Objects	9-15

9-1 Reusing Objects

The Sysmac Studio provides the following two functions to simplify and increase the speed of the development of HMI applications.

- Intelligent application gadgets (IAGs)
- Custom objects

IAGs and custom objects are different in the following ways.

- You can distribute IAGs to other parties. You can use custom objects only on the Sysmac Studio.
- You must treat IAGs as IAGs even after you place them on pages. You treat custom objects like any other objects after you place them on pages.
- After you place an IAG on a page, you can change only the properties of the IAG objects. You can change any of the attributes of custom objects.
- You can hide the contents of subroutines in IAGs. Therefore, you can provide IAGs to other parties without disclosing technology.

You can customize objects yourself and create reusable objects that combine other objects.

9-2 IAGs

An IAG is a library object that you can distribute to other parties. To create a new IAG, you must create it in an IAG project. This section describes the procedures to create and use IAGs.

9-2-1 Differences when an IAG Project Is Selected

Even when an IAG project is selected, basic operations are generally the same as for a standard project. However, the following items are different.

Layers and Items in the Multiview Explorer

The structure of the Multiview Explorer when you select an IAG project is shown below. You can edit the user-defined variables, subroutines, and other resources in an IAG from the menu that is displayed when you right-click the IAG.

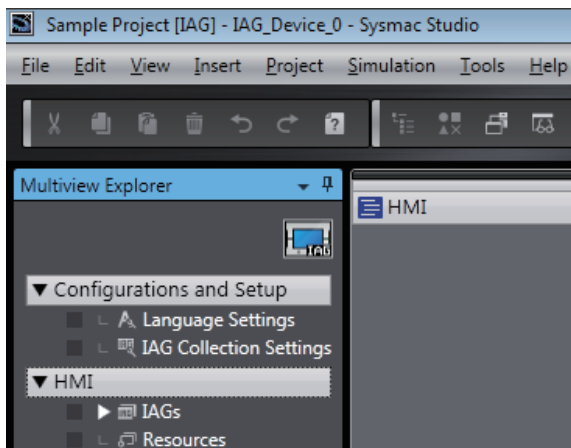

Configurations and Setup	HMI
Language Settings	IAGs
IAG Collection Settings	Resources

Toolbar

This section describes the differences in the Toolbar compared with a standard project.

● Insert Menu

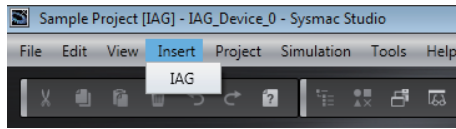

Item	Description	Remarks
IAG	Inserts a new IAG in IAGs.	

● Project Menu

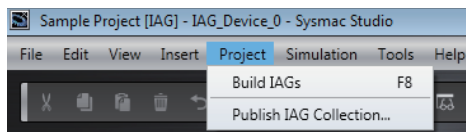

Item	Description	Remarks
Build IAGs	Builds all of the IAGs.	
Publish IAG Collection	Saves an IAG collection in a file format that you can use in a standard project.	

Language Settings

You can set the languages to use in the IAG.

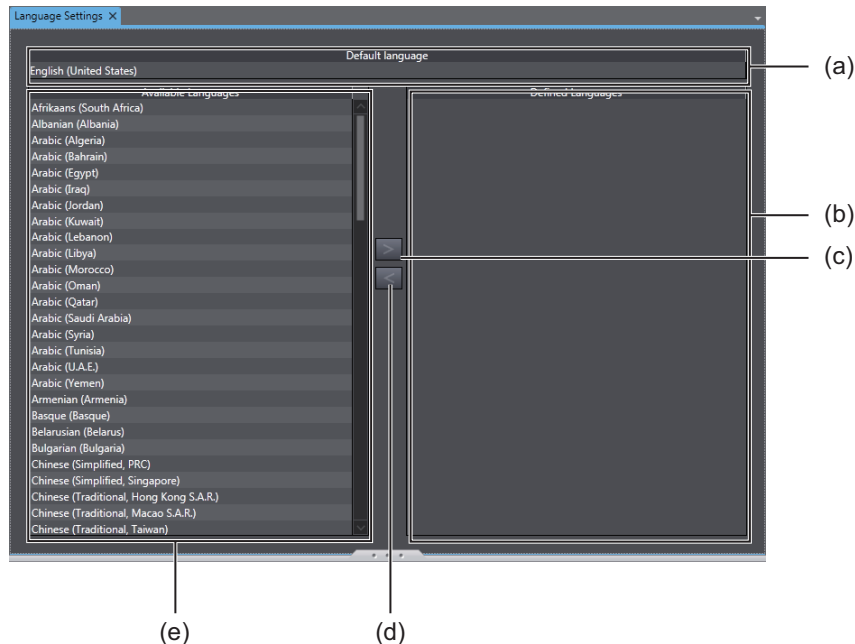

Symbol	Item	Description	Remarks
(a)	Default language	Sets the language that is selected by default.	
(b)	Defined Languages	Displays the languages that you select.	
(c)	>	This button moves a selected language to the defined language list.	
(d)	<	This button deletes a selected language from the defined language list.	
(e)	Available Languages	Displays the languages that you can select.	

IAG Collection Settings

You can make the following settings for an IAG collection.

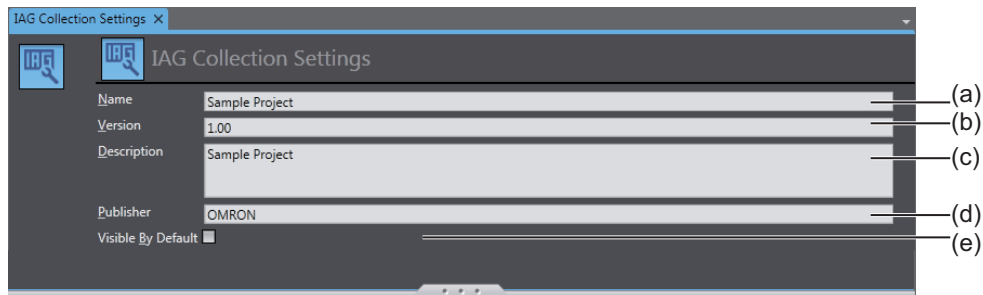

Symbol	Item	Description	Remarks
(a)	Name	Sets the name.	
(b)	Version	Sets the version.	
(c)	Description	Sets a description.	
(d)	Publisher	Sets the publisher.	
(e)	Visible By Default	Select this check box to display the IAG collection in the Toolbox when the IAG collection is imported into the Sysmac Studio.	

IAGs

The following tab page is used to create an IAG. The procedures are generally the same as for standard projects, except for the following differences.

- There are no global variables. Only local variables for each IAG can be used.
- You cannot set page animations, and you cannot set page events and actions.
- You cannot use functions that cannot be placed on a page, such as global events and recipes.
- You cannot use Trend Graph objects and user-created IAGs.

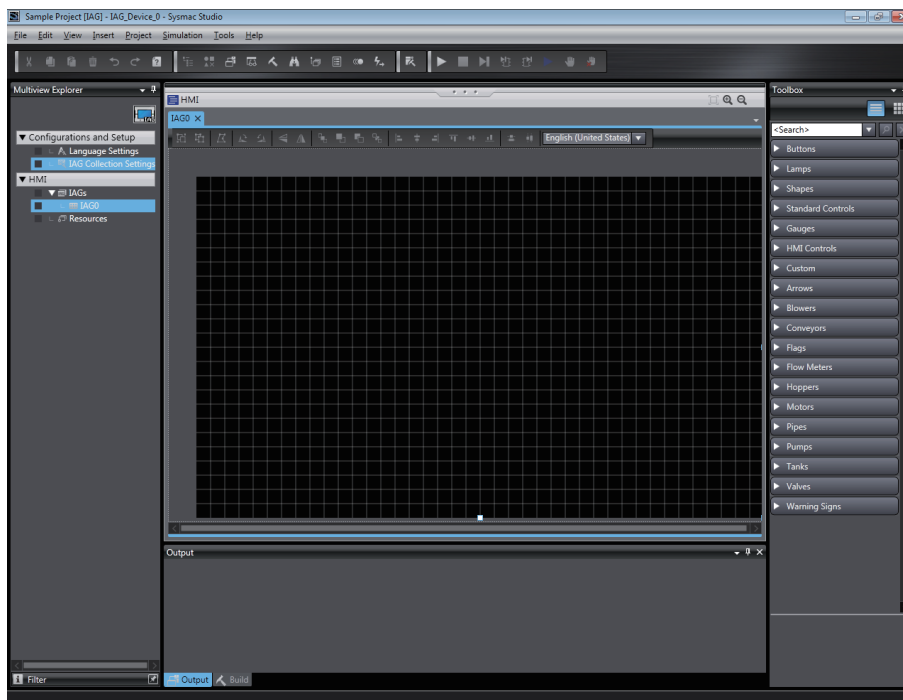

Resources

You can set the resources to use in the IAG. The procedures are the same as for a standard project.

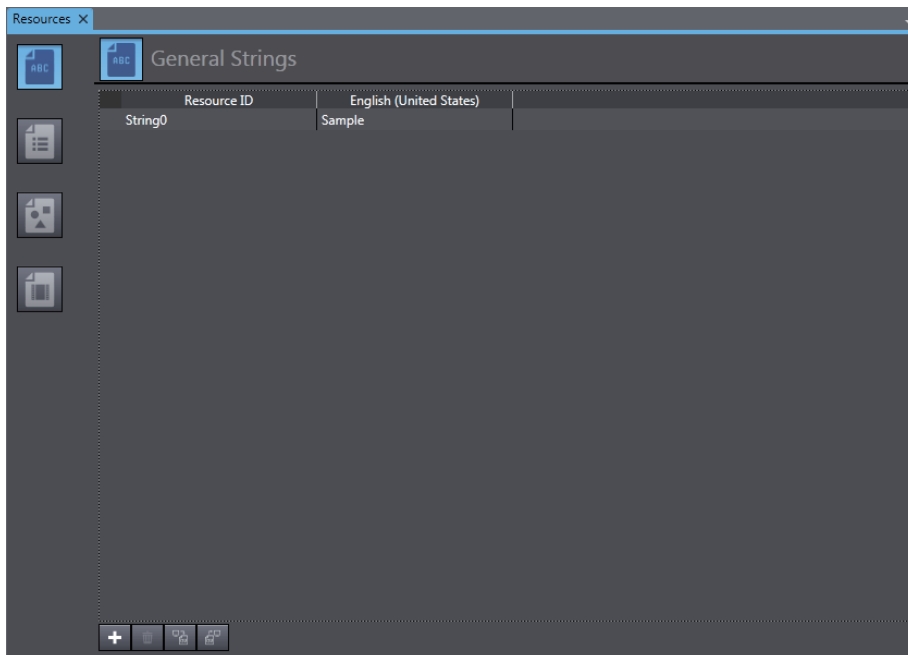

9-2-2 Creating an IAG

This section describes how to create an IAG.

The size of the IAG will be the size of the page when the IAG is created. Any objects that are positioned outside of the page are ignored.

- 1 Create a new project and set the project type to *IAG Project*.

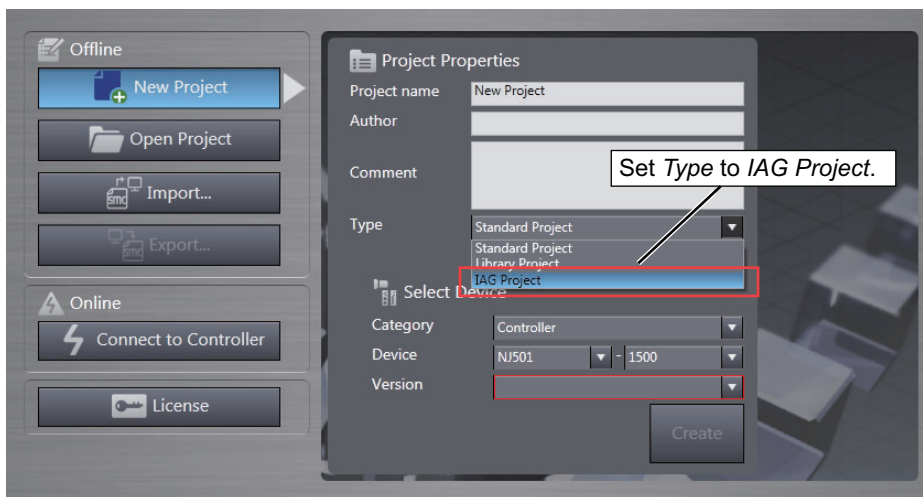

2 Click the **Create** Button.

An IAG project is created and the following window is displayed.

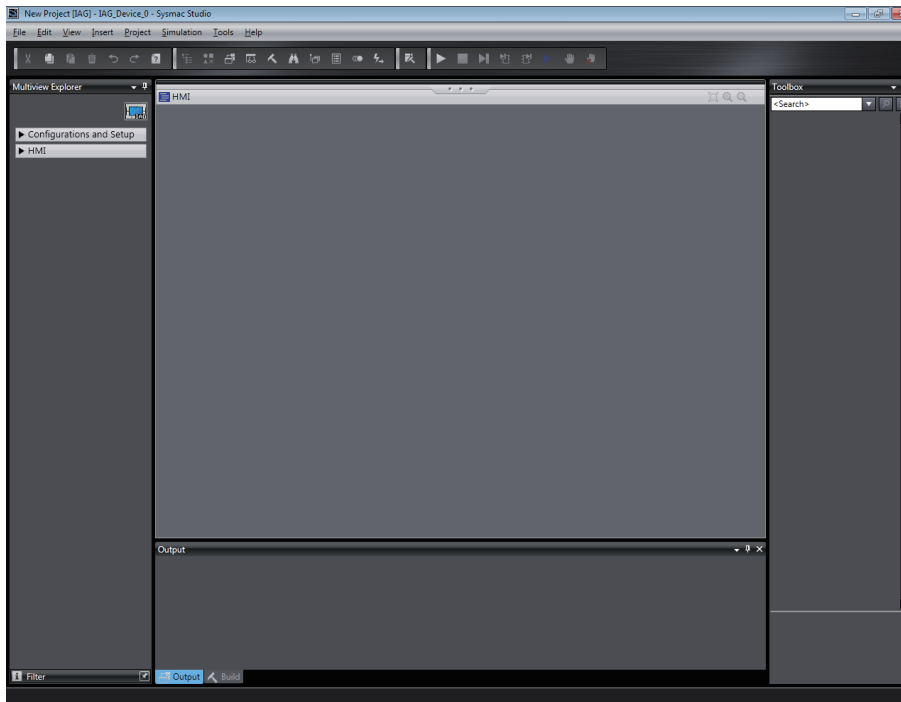

3 Create the IAG with the same methods as for a normal page.

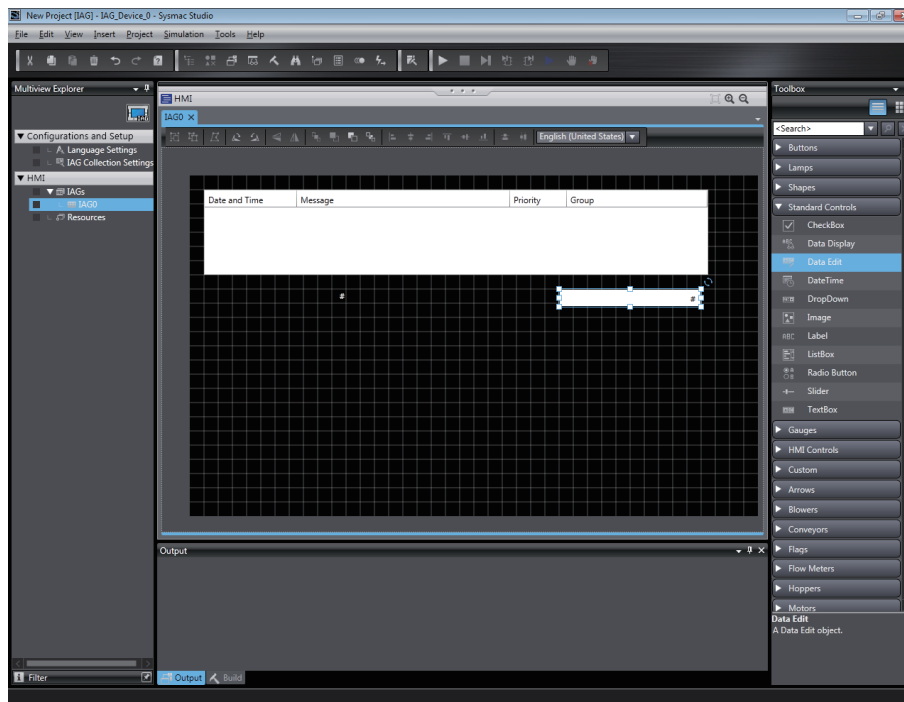

4 Select **Build IAGs** from the Project Menu.

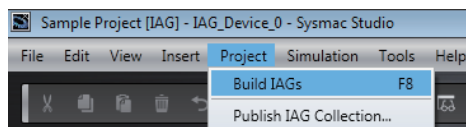

5 Select **Publish IAG Collection** from the Project Menu.

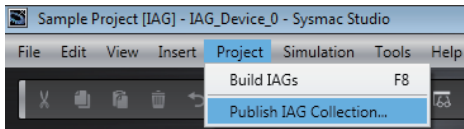

6 Click the **Browse** Button (...) and specify where to save the collection.

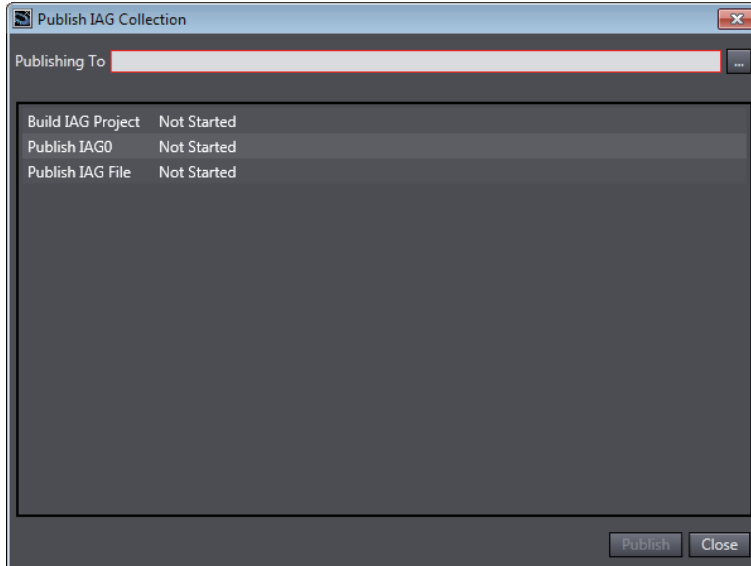

7 Click the **Publish** Button. The IAG collection is created.

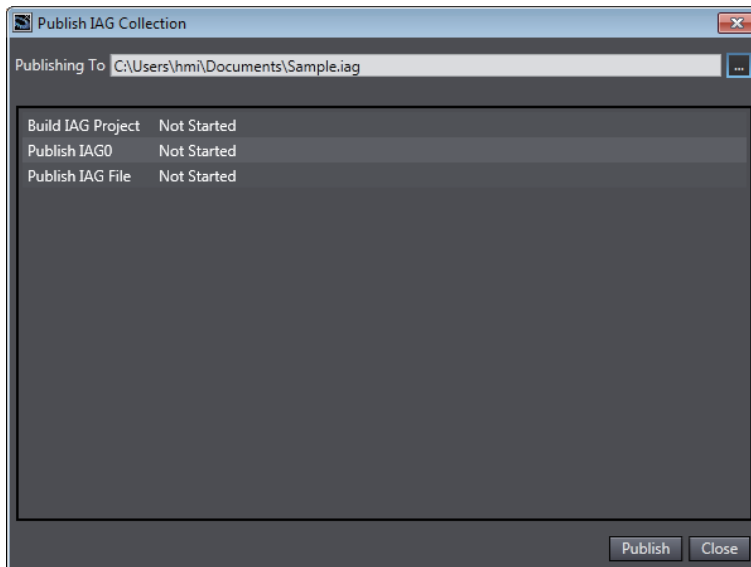

9-2-3 Using IAGs

This section describes how to use the IAGs that you create when you edit a standard project.

To use IAGs, you must first register them in the Toolbox. After you register them in the Toolbox, you can drag them to the page to use them in the same way as for other objects.

Registering IAGs

- 1 Select *IAG Collections Manager* from the Project Menu.

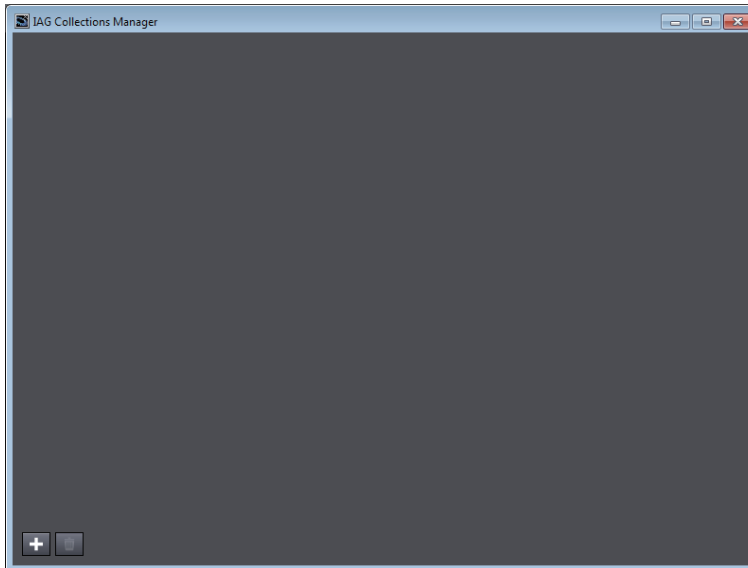

- 2 Click the + Button. Select the IAG file and click the **Open** Button.

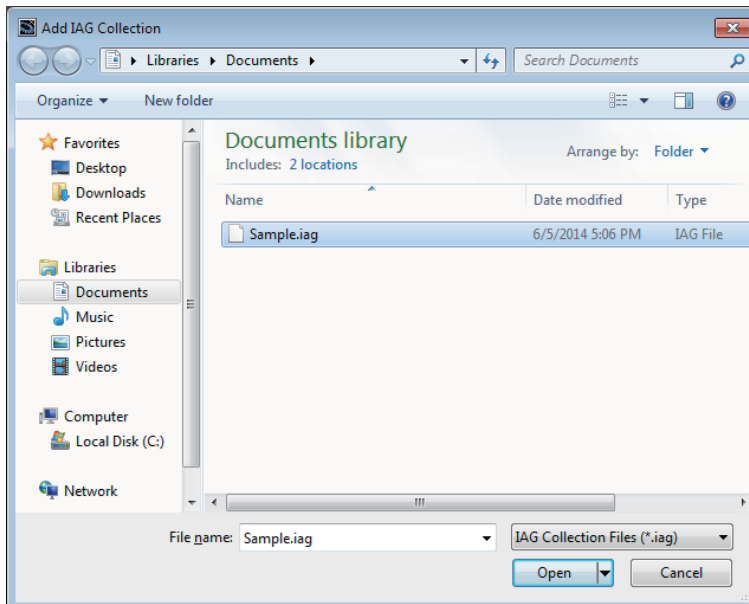

- 3 Select the *Show in Toolbox* Check Boxes for the IAG collections that you want to display in the Toolbox.

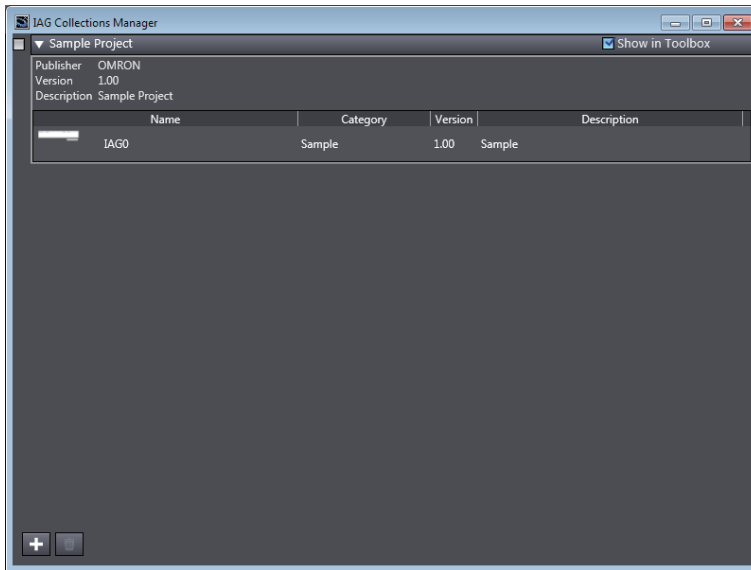

- 4 The IAGs for the selected check boxes are displayed in the Toolbox.

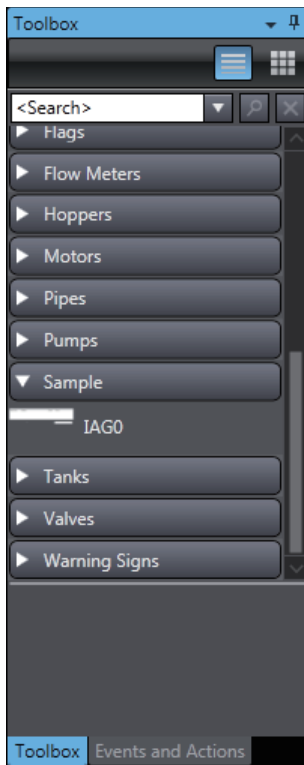

9-3 Custom Objects

You can register the objects that you use most frequently to increase your productivity. This section describes the procedures to create and use custom objects.

9-3-1 Objects That You Can Register as Custom Objects

An object must meet the following conditions before you can register it as a custom object.

- You can register only individual objects.
You cannot register more than one object as a custom object. If you want to register more than one object as a custom object, group the objects into one object first.
- The object cannot be a user-defined IAG.
You cannot register a user-defined IAG or a group that contains a user-defined IAG as a custom object.

9-3-2 Creating Custom Objects

Use the following procedure to create a custom object.

- 1 Create a standard project and place the objects to register as a custom object on the page.

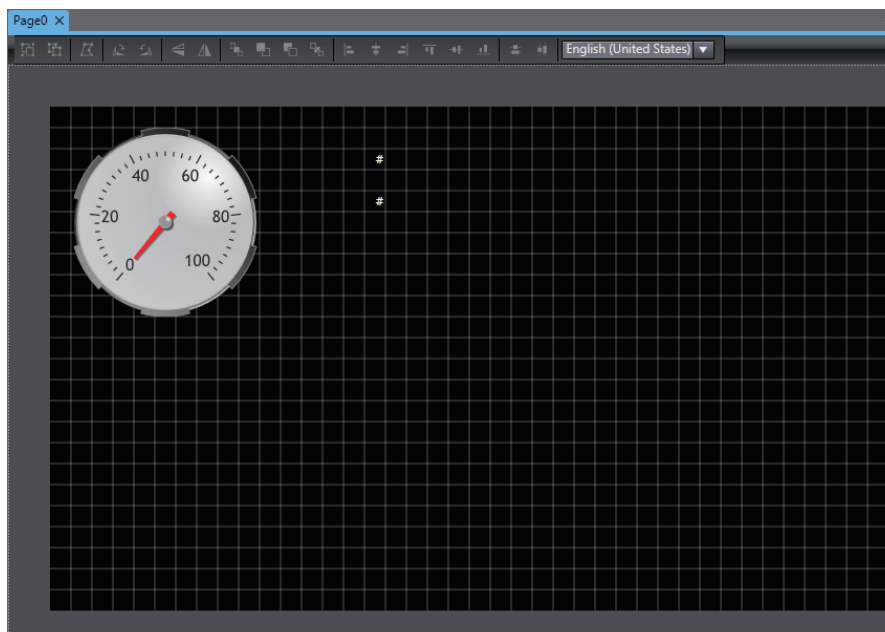

2 Group the objects to register the group as a custom object.

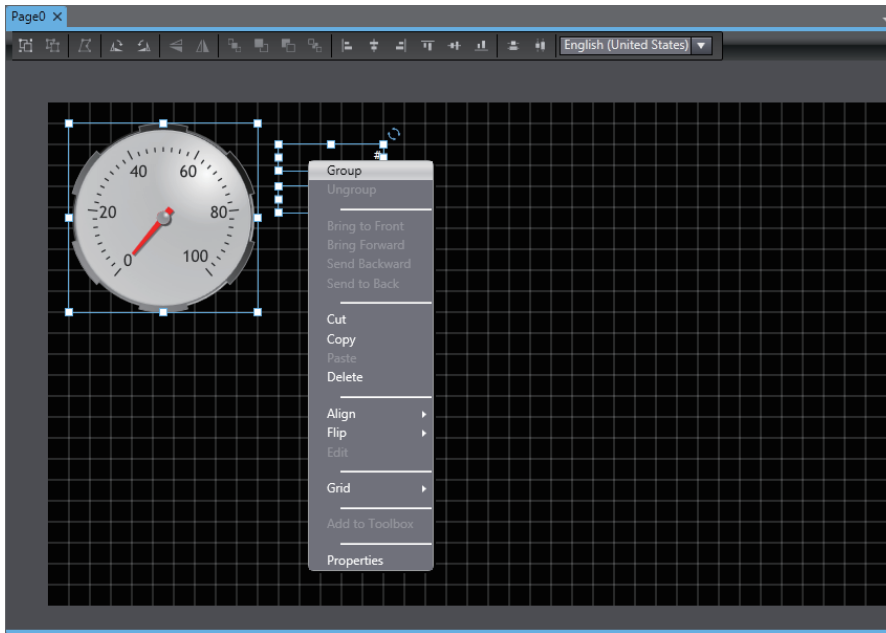

3 Right-click the group of objects and select **Add to Toolbox** from the menu.

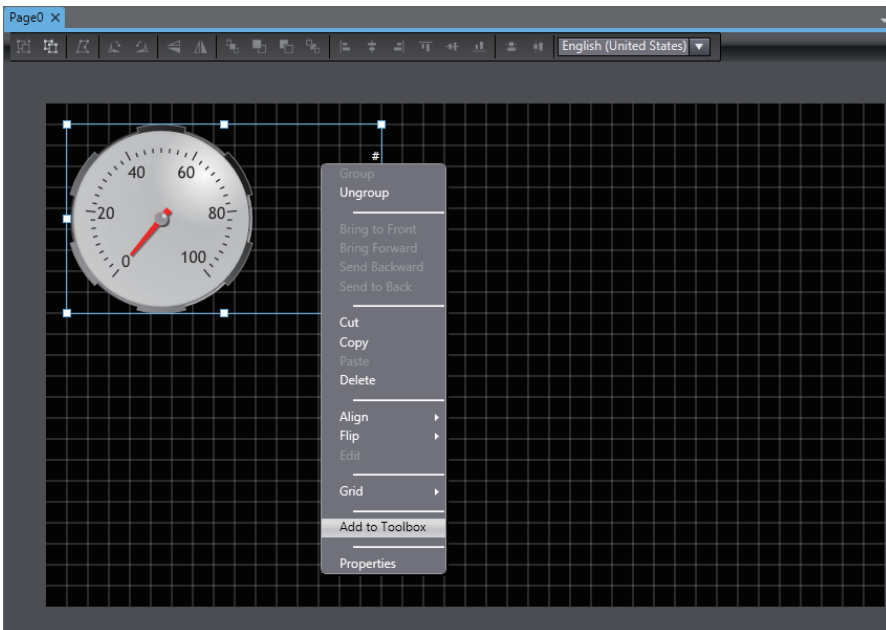

- 4 The group is added as a custom object under **Custom** in the Toolbox. The displayed name is the name of the registered group or object.



9-3-3 Deleting Custom Objects

Use the following procedure to delete a registered custom object.

- 1 Right-click the custom object to delete from the Toolbox. Select **Delete** from the menu.

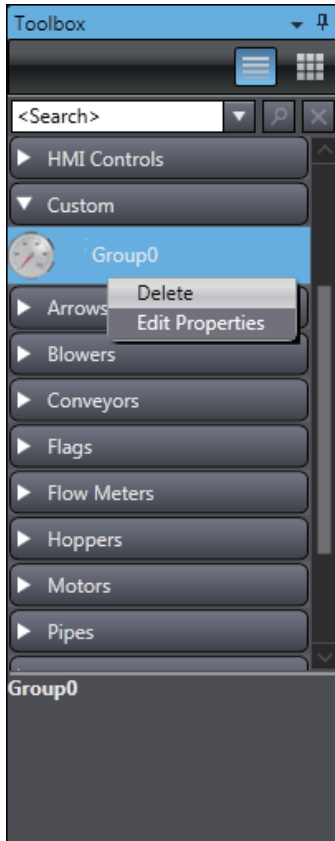

- 2 A confirmation dialog box is displayed. Click the **Yes** Button.

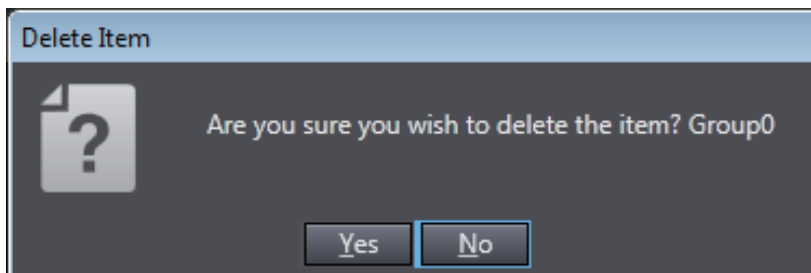

9-3-4 Using Custom Objects

It is very easy to use a custom object. Just select the desired custom object in the Toolbox and drag it to the page. You can handle the custom objects on pages in the same ways as you handle normal objects.

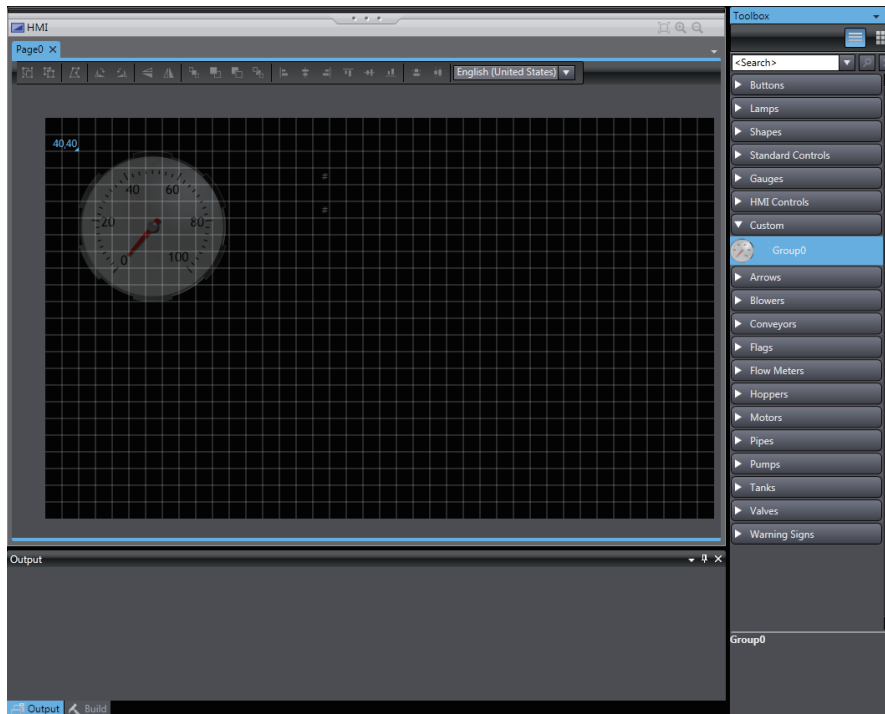

10

Connecting to HMIs from External Devices

This section describes how to connect to an HMI from an external device.

10-1 Accessing an HMI from an External Device	10-2
10-1-1 VNC	10-2
10-1-2 FTP	10-3

10-1 Accessing an HMI from an External Device

You can use the following two methods to access an NA-series Programmable Terminal from an external device.

- Remote monitoring and control with VNC
- File operations with FTP



Precautions for Correct Use

- Only password security is provided for using VNC and FTP. Sufficiently consider the network configuration in terms of security and implement any required measures to prevent unauthorized access.
- Use the same keyboard layout settings for the VNC client computer and the HMI. If the settings are not the same, different characters may result from the characters input from the VNC client.

10-1-1 VNC

You can enable VNC to use a VNC client to monitor and control HMI pages. You can also use a mode setting to prohibit controlling operation from a VNC client and allow only monitoring.

Setting Method

Double-click **HMI Settings** under **Configurations and Setup**. Click the **VNC Settings** Button.

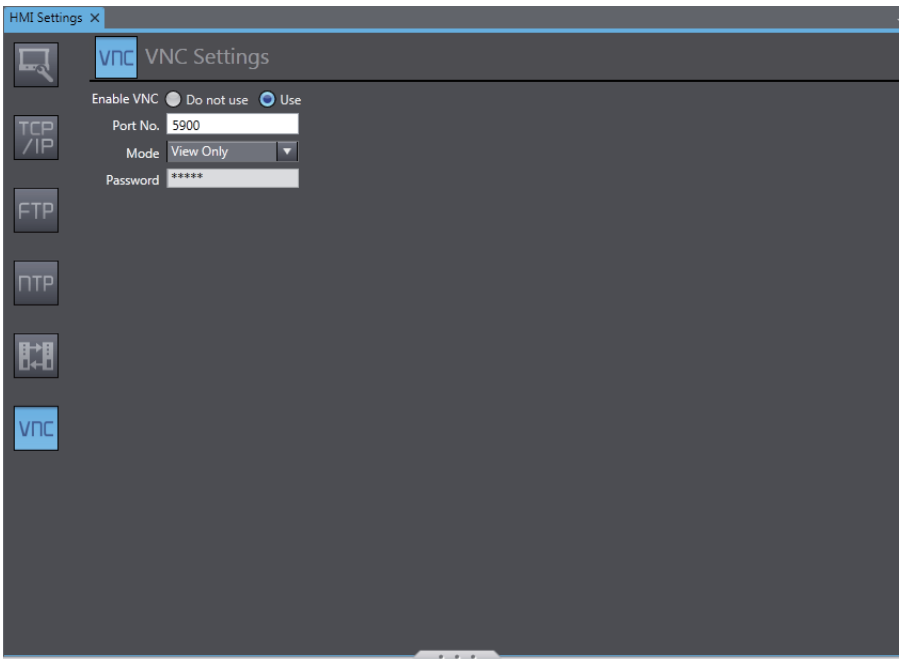

Select the *Use* Option for *Enable VNC* and change the setting of the *Mode* Box as required. Set a text string in the *Password* Box.

After you complete the settings, select **Build HMI** from the Project Menu. When building the project is completed, download the project to the HMI.

After the download is completed, you can access the HMI from a VNC client.



Additional Information

Refer to the relevant software manuals for the operating procedures of the VNC client.

10-1-2 FTP

You can enable the FTP server to use an FTP client to access files in the HMI. However, you can access only specific folder.

Setting Method

Double-click **HMI Settings** under **Configurations and Setup**. Click the **FTP Settings** Button.

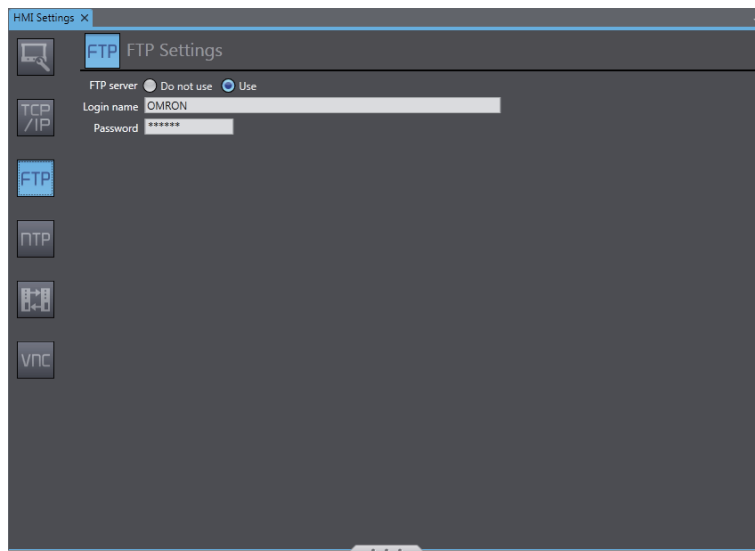

Select the *Use* Option. Set text strings for the login name and password.

After you complete the settings, select **Build HMI** from the Project Menu. When building the project is completed, download the project to the HMI.

After the download is completed, you can access the HMI from an FTP client.



Additional Information

Refer to the relevant software manuals for the operating procedures of the FTP client.

11

Other Functions

This section describes other functions that the Sysmac Studio provides for HMIs.

11-1 Sysmac Studio Option Settings	11-2
---	-------------

11-1 Sysmac Studio Option Settings

The following Sysmac Studio option settings are related to HMIs.

- HMI Code Editor
- HMI Page Editor

HMI Code Editor

You can make settings to highlight text in the HMI Code Editor.

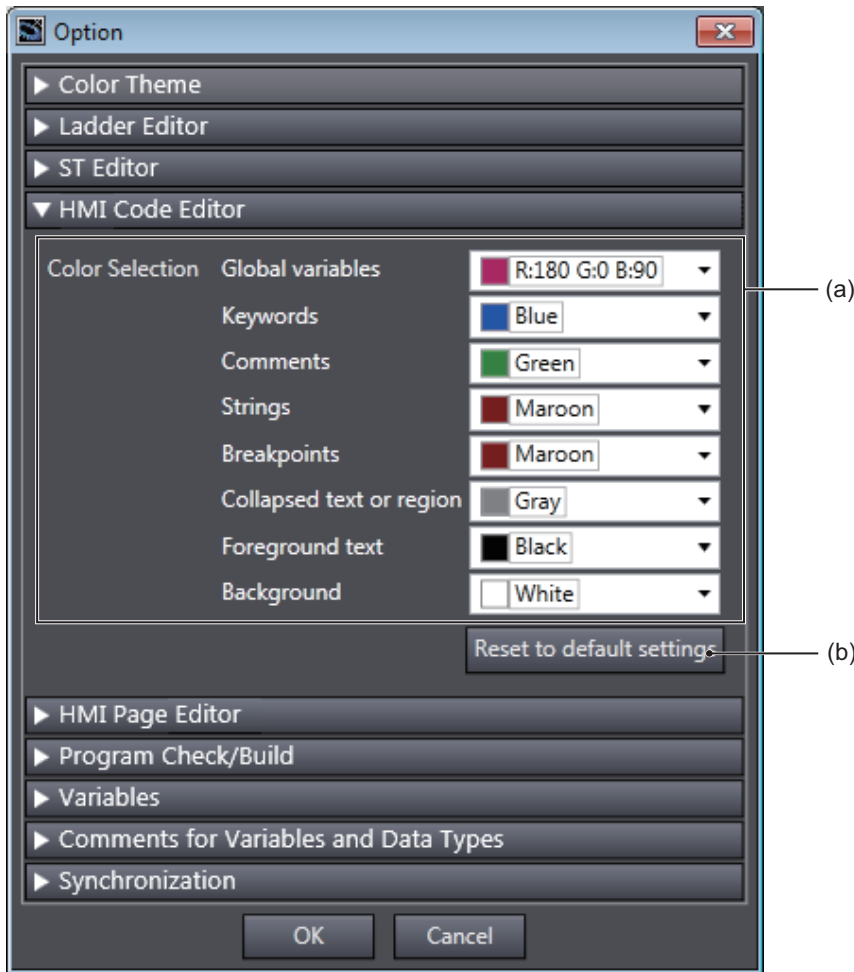

Symbol	Item	Description	Remarks
(a)	Color Selections	Select the color for each item.	
(b)	Reset to default settings	This button resets the colors to the default settings.	

HMI Page Editor

You can make settings for the grid in the HMI Page Editor.

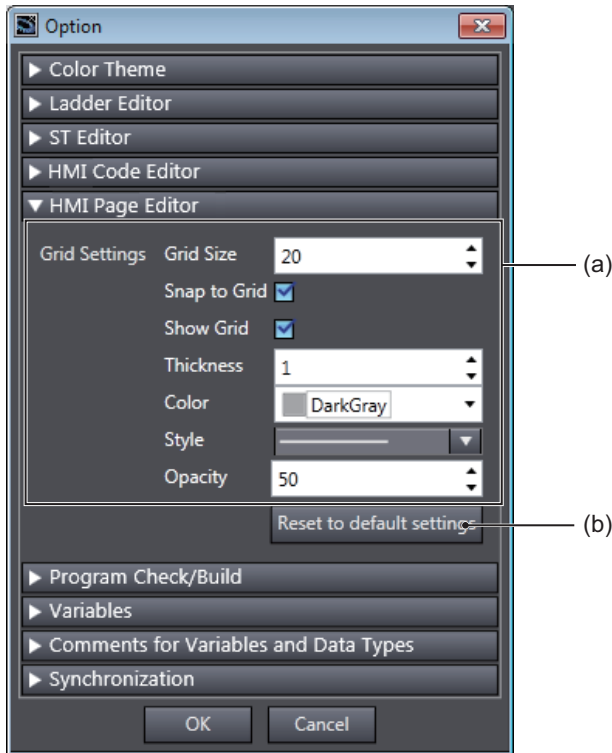

Symbol	Item	Description	Remarks
(a)	Grid Settings	Make the settings for the grid.	
(b)	Reset to Defaults	This button restores the default grid settings.	

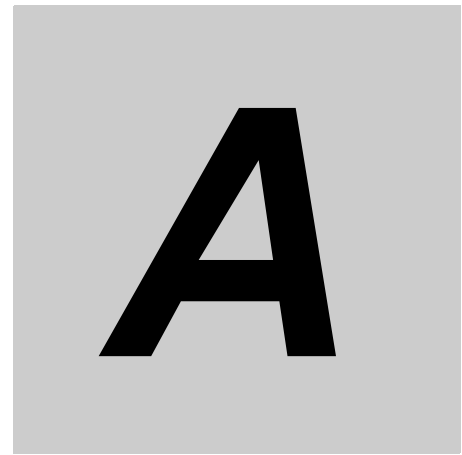

Appendices



The appendices provide information on supported file formats and other information.

A-1 Events and Actions	A-2
A-2 Supported Formats	A-4
A-3 Differences between the Physical HMI and Simulator	A-5

A-1 Events and Actions

Events

Name	Description	Global events	Page	Objects	User alarms
Acknowledged	The event occurs when the user alarm is acknowledged.	—	—	—	Yes
Checked	The event occurs when the check box is selected.	—	—	Yes	—
Cleared	The event occurs when the user alarm is cleared.	—	—	—	Yes
Click ^{*1}	The event occurs when the object is tapped.	—	—	Yes	—
Condition	The event occurs when the set condition is met.	Yes	Yes	—	—
F1 Key Click ^{*1}	The event occurs when the F1 Key is tapped.	Yes	Yes	—	—
F1 Key Press	The event occurs while the F1 Key is held down.	Yes	Yes	—	—
F1 Key Release ^{*1}	The event occurs when the F1 Key is released.	Yes	Yes	—	—
F2 Key Click ^{*1}	The event occurs when the F2 Key is tapped.	Yes	Yes	—	—
F2 Key Press	The event occurs while the F2 Key is held down.	Yes	Yes	—	—
F2 Key Release ^{*1}	The event occurs when the F2 Key is released.	Yes	Yes	—	—
F3 Key Click ^{*1}	The event occurs when the F3 Key is tapped.	Yes	Yes	—	—
F3 Key Press	The event occurs while the F3 Key is held down.	Yes	Yes	—	—
F3 Key Release ^{*1}	The event occurs when the F3 Key is released.	Yes	Yes	—	—
Interval	The event occurs at the specified interval.	Yes	—	—	—
Page Displayed	The event occurs when the page is displayed.	—	Yes	—	—
Page Hidden	The event occurs when the page is hidden.	—	Yes	—	—
Press	The event occurs while the object is held down.	—	—	Yes	—
Project Initialization ^{*2}	The event occurs when the project is initialized.	Yes	—	—	—
Raised	The event occurs when the user alarm occurs.	—	—	—	Yes
Release ^{*1}	The event occurs when the object is released.	—	—	Yes	—
Selection Changed	The event occurs when the item selected in the list changes.	—	—	Yes	—
Unchecked	The event occurs when the check box selection is cleared.	—	—	Yes	—

*1. For both *Click* and *Release*, the event occurs when the object is released, but the operation when the page is changed is different. If the page changes when an object set for *Click* is touched but not yet released, the event does not occur. If the page changes when an object set for *Release* is touched but not yet released, the event does occur.

*2. The results of accessing external variables during project initialization immediately after startup are not always dependable. Do not access external variables during project initialization.

Actions

Action	Description	Global events	Page	Objects	User alarms
CallSubroutine	Executes a subroutine registered as a global subroutine or page subroutine.	Yes ^{*1}	Yes	Yes	Yes ^{*1}
ClearUserAlarmLog	Clears the user alarm log.	Yes	Yes	Yes	Yes
ClosePage	Closes the specified page.	Yes	Yes	Yes	Yes
DecreaseVariable	Subtracts the specified value from the specified variable.	Yes	Yes	Yes	Yes
EjectSDMemory	Enables removing the SD Memory Card.	Yes	Yes	Yes	Yes
EnableInputOperation	Enables or disables inputs on the touch panel.	Yes	Yes	Yes	Yes
IncreaseVariable	Adds the specified value to the specified variable.	Yes	Yes	Yes	Yes
InvertVariable	Inverts the value of the specified Boolean variable.	Yes	Yes	Yes	Yes
Login	Displays the login page.	Yes	Yes	Yes	Yes
Logout	Logs out the user.	Yes	Yes	Yes	Yes
ResetVariable	Changes the value of the specified Boolean variable to False.	Yes	Yes	Yes	Yes
SaveUserAlarmLogToFile	Saves the user alarm log to a file.	Yes	Yes	Yes	Yes
SetBrightness	Changes the brightness of the screen.	Yes	Yes	Yes	Yes
SetLanguage	Changes the project language settings.	Yes	Yes	Yes	Yes
SetVariable	Sets the value of the specified variable to a specified value.	Yes	Yes	Yes	Yes
ShowDocument(FULL SCREEN)	Displays a PDF or other file full screen.	Yes	Yes	Yes	Yes
ShowDocument(Window)	Displays a PDF or other file in a window.	Yes	Yes	Yes	Yes
ShowPage ^{*2}	Displays a page.	Yes	Yes	Yes	Yes
ShowPreviousPage ^{*2}	Displays the most recently displayed page.	Yes	Yes	Yes	Yes
ShowSystemMenu	Displays the System Menu.	Yes	Yes	Yes	Yes
StartDataLogging	Starts data logging.	Yes	Yes	Yes	Yes
StopDataLogging	Stops data logging.	Yes	Yes	Yes	Yes

*1. You cannot execute page subroutines for global events or user alarms.

*2. If you execute an action with a Momentary Button, use a Click or Release event.

A-2 Supported Formats

The HMI objects support the following formats. However, it may not be possible to display some files even if the file format is supported.

Image Files

The following formats are supported.

Format name	Extension	Specifications
Microsoft Windows Bitmap Image	BMP	1, 4, 8, 16, 24, or 32-bit Uncompressed or RLE compression
Graphics Interchange Format	GIF	1, 4, or 8-bit Transparent GIF or interlaced GIF
JFIF or EXIF	JPG	8-bit gray scale 24-bit/basic DCT or progressive DCT
Portable Network Graphics	PNG	1, 4, 8, or 24-bit Transparency is supported.

Video

The following formats are supported. However, only progressive formats are supported.

Format name	Extension	Specifications	Maximum resolution
MPEG-1	mpg	The MPEG-1 Video Stream format is not supported.	768×480
MPEG-2	mpg	Main Profile Low, Main, and High 1440 MPEG-2 TS is not supported.	1280×720
MPEG-4 Part 2	mp4	Simple Profile L0, L1, L2, and L3 Advanced Simple Profile L0, L1, L2, L3, L4, and L5 Global motion compensation is not supported.	1280×720
MPEG-4 Part 10 (H.264)	mp4	Baseline Profile L1, L1.2, L1.3, L2, L2.2, and L3 Main Profile L1, L1.2, L1.3, L2, L2.2, L3, L3.1, L3.2, and L4.1 High Profile L1, L1.2, L1.3, L2, L2.2, L3, L3.1, L3.2, and L4.1	1280×720
Windows Media Video	wmv	WMV9	240×160

Files Supported by Document Viewer

The Document Viewer can display the following files.

Format name	Extension	Specifications
Adobe Acrobat Document	PDF	
Microsoft Excel Books	xlsx	
Microsoft Excel 97-2003 Books	xls	
Microsoft Word Documents	docx	
Microsoft Word 97-2003 Documents	doc	

A-3 Differences between the Physical HMI and Simulator

The following differences exist between the physical HMI and Simulator.

- **Trend Graph Objects**
The Simulator cannot display graphs. Only the frames are displayed.
- **Media Player Objects**
Although the Simulator will execute more than one Media Player object on the same page, the physical HMI never executes more than one.
- **ShowDocument Action and ShowDocument Function**
The Simulator ignores parameters that specify the display positions and sizes for documents. To display documents, there must be a compatible application, such as Adobe Reader. The application used to display a document will not be exited when the Simulator is exited or the page is changed after the document is displayed. Exit the application manually.



Index



A

actions 4-22, A-3
 adding an HMI 2-14
 alarms 1-9
 animations 5-6

B

Battery 1-9
 breakpoints 7-3
 building 4-33

C

Clear All Memory 3-22
 Code Editor 4-31
 Code Explorer 2-4
 Communications Setup 6-4
 comparison results 8-3
 connected devices 3-3
 Continue 7-5
 creating a project file 2-13
 creating pages 4-11
 custom objects 9-11

D

data logging 1-9, 4-20
 debugging functions 7-2
 device references 3-3
 device settings 3-11
 differences between the physical HMI and Simulator A-5

E

entry assistance 2-8
 entry methods for global variables 4-5
 events 1-7, A-2
 events and actions 5-6
 examples of using objects 5-11
 external 3-3
 external connected devices 3-3
 external variables 3-8, 4-2, 4-4

F

FINS settings 3-15
 FTP 10-3
 FTP settings 3-13
 functional objects 5-2

G

global events 4-22
 global subroutines 4-24, 4-27
 global variables 4-2
 graphic objects 5-3

H

HMI clock 3-19
 HMI Code Editor 11-2
 HMI Name 3-20
 HMI Page Editor 11-3
 HMI projects 1-4
 HMI software configuration 1-4
 HMI versions 2-15
 HMI Write 3-21

I

IAG collection settings 9-5
 IAG resources 4-26
 IAGs 9-3, 9-5
 importing device variables 3-6
 internal connected devices 3-3
 internal variables 4-2

L

language settings 3-18, 9-4
 language specifications 4-31

M

main pages 4-11
 mapping variables 3-7
 memory specifications 1-6
 menu 2-6
 Multiview Explorer 2-3

N

NA-series Programmable Terminals 1-2
 new user alarm 4-18
 notation for CustomDisplayFormat 5-5
 notation for expression 5-5
 NTP settings 3-14

O

object attributes 5-3
 object list 5-2
 objects 1-5, 5-2
 offline comparison 4-34
 offline debugging 7-6, 7-7
 online connection 6-2
 operating procedure 1-10
 option settings 11-2

P

Page Explorer 2-4
 page subroutines 4-27
 pages 1-4
 PDF file 5-11

popup pages4-11
 properties5-4

R

recipe5-17
 recipes 1-9, 4-21
 registering IAGs9-9
 reset3-23
 resources 1-9, 4-25, 9-6

S

search and replace4-32
 security settings3-17
 serial IDs6-6
 simulator connection6-2
 step execution7-4
 step-in execution7-4
 step-out execution7-5
 storage media8-5
 subroutine execution4-28
 subroutine group4-24
 subroutine variables 4-2, 4-10
 subroutines 1-8, 4-27
 supported formats A-4
 synchronizing projects8-2
 system-defined variables 4-2, 4-8, 4-9

T

TCP/IP settings3-12
 Toolbar 4-16, 9-4
 Toolbox2-5
 trend graph5-15

U

updating device variables3-6
 user alarm5-13

V

variables4-2
 VNC10-2
 VNC settings3-16

W

Watch Tab Page7-2

OMRON Corporation Industrial Automation Company
Tokyo, JAPAN

Contact: www.ia.omron.com

Regional Headquarters

OMRON EUROPE B.V.

Wegalaan 67-69-2132 JD Hoofddorp
The Netherlands
Tel: (31)2356-81-300/Fax: (31)2356-81-388

OMRON ELECTRONICS LLC

One Commerce Drive Schaumburg,
IL 60173-5302 U.S.A.
Tel: (1) 847-843-7900/Fax: (1) 847-843-7787

OMRON ASIA PACIFIC PTE. LTD.

No. 438A Alexandra Road # 05-05/08 (Lobby 2),
Alexandra Technopark,
Singapore 119967
Tel: (65) 6835-3011/Fax: (65) 6835-2711

OMRON (CHINA) CO., LTD.

Room 2211, Bank of China Tower,
200 Yin Cheng Zhong Road,
PuDong New Area, Shanghai, 200120, China
Tel: (86) 21-5037-2222/Fax: (86) 21-5037-2200

Authorized Distributor:

© OMRON Corporation 2014 All Rights Reserved.
In the interest of product improvement,
specifications are subject to change without notice.

Cat. No. V118-E1-01

0614